

## Wedge Anchor B A4 / B HCR

Stainless steel A4/316 and Stainless steel 1.4529



**Range of loading:** 2,9 kN - 43,9 kN

**Range of concrete quality:** C20/25 - C50/60



### Description

The tried and tested wedge anchor B with European Technical Assessment, Option 7, is ideal for time-saving through fastenings in non-cracked concrete. Its two effective anchorage depths make it very flexible, reducing contacts with reinforcements when holes are drilled. The long thread also makes stand-off fastenings possible.

The wedge anchor B M6 and HCR is also approved for multiple use for non-structural applications and similar fixtures in cracked and non-cracked concrete.

### Advantages

- Approved for use in non-cracked concrete
- Very high load limits and small spacings and edge distances
- Two effective anchorage depths for greater flexibility
- The smaller effective anchorage depth helps to reduce drilling and installation time
- The standard effective anchorage depth is suitable for fastenings under the highest load limits and small spacings and edge distances
- Particularly cost effective: shorter lengths with only one (smaller) anchorage depth
- Suitable for surface, through, and stand-off fastenings
- Fire tested for fire resistance ratings F30–F120
- US approval (FM) for the installation of sprinkler systems (M10 to M16)
- An impact head protects the thread from damage when it is driven into the drilled hole

### Approvals and Certificates



### Applications

Medium to heavy duty indoor and outdoor use, metal structures, brackets, machines.

Wedge Anchor B M6 A4 and HCR: Multiple use for non-structural applications and similar fixtures in tunnels and or external atmospheric exposures.

**Wedge Anchor B A4**



→ Stainless steel A4/316

→ ETA approval for non-cracked concrete

Description	Ref. No.	Standard anchorage depth				Reduced anchorage depth				Anchor length	Thread	Pkg. content	Weight per pkg.
		Fixture thickness t <sub>fix</sub> mm	Drill hole Ø x Depth mm	Setting Depth h <sub>nom</sub> mm	Anchorage depth h <sub>ef</sub> mm	Fixture thickness t <sub>fix,red</sub> mm	Drill hole Ø x depth mm	Setting Depth h <sub>nom,red</sub> mm	Anchorage depth h <sub>ef,red</sub> mm				
B 6-5/40 A4 <sup>1)</sup>	01005501	-	-	-	-	5	6x35	27	18	40	M6x16	100	1,06
B 6-5/52 A4	01006501	-	-	-	-	5	6x45	39	30	52	M6x20	100	1,27
B 6-10-20/67 A4	01010501	10	6x55	49	40	20	6x45	39	30	67	M6x30	100	1,56
B 6-25-35/82 A4	01015501	25	6x55	49	40	35	6x45	39	30	82	M6x35	100	1,80
B 6-40-50/97 A4	01025501	40	6x55	49	40	50	6x45	39	30	97	M6x35	100	2,08
B 8-5/50 A4 <sup>1)</sup>	01105501	-	-	-	-	5	8x45	35	24	50	M8x22	100	2,34
B 8-4/60 A4	01110501	-	-	-	-	4	8x55	47	35	60	M8x25	100	2,64
B 8-10-19/75 A4	01115501	10	8x65	56	44	19	8x55	47	35	75	M8x40	100	3,10
B 8-15-24/80 A4	01120501	15	8x65	56	44	24	8x55	47	35	80	M8x45	100	3,28
B 8-20-29/85 A4	01125501	20	8x65	56	44	29	8x55	47	35	85	M8x50	100	3,42
B 8-30-39/95 A4	01135501	30	8x65	56	44	39	8x55	47	35	95	M8x60	100	3,73
B 8-45-54/110 A4	01145501	45	8x65	56	44	54	8x55	47	35	110	M8x75	100	4,20
B 8-55-64/120 A4	01150501	55	8x65	56	44	64	8x55	47	35	120	M8x85	100	4,57
B 10-10/60 A4 <sup>1)</sup>	01205501	-	-	-	-	10	10x50	40	25	60	M10x25	50	2,30
B 10-10-16/85 A4	01210501	10	10x70	62	48	16	10x65	56	42	85	M10x40	50	2,85
B 10-15-21/90 A4	01215501	15	10x70	62	48	21	10x65	56	42	90	M10x45	50	2,97
B 10-20-26/95 A4	01220501	20	10x70	62	48	26	10x65	56	42	95	M10x50	50	3,10
B 10-30-36/105 A4	01225501	30	10x70	62	48	36	10x65	56	42	105	M10x60	50	3,33
B 10-45-51/120 A4	01230501	45	10x70	62	48	51	10x65	56	42	120	M10x75	50	3,75
B 10-50-56/125 A4	01235501	50	10x70	62	48	56	10x65	56	42	125	M10x80	50	3,87
B 10-70-76/145 A4	01240501	70	10x70	62	48	76	10x65	56	42	145	M10x80	50	4,38
B 10-100-106/175 A4	01245501	100	10x70	62	48	106	10x65	56	42	175	M10x80	50	5,15
B 10-140-146/215 A4	01250501	140	10x70	62	48	146	10x65	56	42	215	M10x80	25	3,10
B 12-5/75 A4 <sup>1)</sup>	01305501	-	-	-	-	5	12x65	55	38	75	M12x30	25	1,96
B 12-14/95 A4	01310501	-	-	-	-	14	12x75	66	50	95	M12x50	25	2,33
B 12-10-25/105 A4	01312501	10	12x90	81	65	25	12x75	66	50	105	M12x60	25	2,53
B 12-15-30/110 A4	01315501	15	12x90	81	65	30	12x75	66	50	110	M12x65	25	2,62
B 12-20-35/115 A4	01320501	20	12x90	81	65	35	12x75	66	50	115	M12x70	25	2,70
B 12-30-45/125 A4	01325501	30	12x90	81	65	45	12x75	66	50	125	M12x80	25	2,88
B 12-50-65/145 A4	01330501	50	12x90	81	65	65	12x75	66	50	145	M12x100	25	3,28
B 12-65-80/160 A4	01335501	65	12x90	81	65	80	12x75	66	50	160	M12x100	25	3,55
B 12-85-100/180 A4	01340501	85	12x90	81	65	100	12x75	66	50	180	M12x100	25	3,90
B 12-105-120/200 A4	01345501	105	12x90	81	65	120	12x75	66	50	200	M12x100	25	4,28
B 12-145-160/240 A4	01355501	145	12x90	81	65	160	12x75	66	50	240	M12x80	20	4,39
B 16-5/90 A4 <sup>1)</sup>	01505501	-	-	-	-	5	16x75	65	47	90	M16x35	20	3,37
B 16-14/115 A4	01510501	-	-	-	-	14	16x95	83	64	115	M16x60	20	3,98
B 16-10-26/130 A4	01512501	10	16x110	99	80	26	16x95	83	64	130	M16x70	20	4,34
B 16-30-46/150 A4	01515501	30	16x110	99	80	46	16x95	83	64	150	M16x90	20	4,87
B 16-60-76/180 A4	01520501	60	16x110	99	80	76	16x95	83	64	180	M16x110	20	5,66
B 16-80-96/200 A4	01525501	80	16x110	99	80	96	16x95	83	64	200	M16x110	10	3,26
B 16-100-116/220 A4	01530501	100	16x110	99	80	116	16x95	83	64	220	M16x80	10	3,59
B 16-130-146/250 A4	01535501	130	16x110	99	80	146	16x95	83	64	250	M16x80	10	3,99
B 16-200-216/320 A4	01545501	200	16x110	99	80	216	16x95	83	64	320	M16x80	10	5,16
B 20-5-27/150 A4	01605501	5	20x130	121	100	27	20x110	99	78	150	M20x70	10	3,86
B 20-35-57/180 A4	01610501	35	20x130	121	100	57	20x110	99	78	180	M20x70	10	4,47
B 20-60-82/205 A4	01612501	60	20x130	121	100	82	20x110	99	78	205	M20x70	10	5,03
B 20-95-117/240 A4	01615501	95	20x130	121	100	117	20x110	99	78	240	M20x70	10	6,26

<sup>1)</sup>Not part of assessment. HCR on demand.

**Wedge Anchor B HCR**



→ High corrosion resistant steel 1.4529 (HCR)

→ Approved for multiple use for non-structural applications

Description	Ref. No.	Standard anchorage depth				Reduced anchorage depth				Anchor length	Thread	Pkg. content	Weight per pkg.
		Fixture thickness t <sub>fix</sub> mm	Drill hole Ø x depth mm	Setting depth h <sub>nom</sub> mm	Anchorage depth h <sub>ef</sub> mm	Fixture thickness t <sub>fix,red</sub> mm	Drill hole Ø x depth mm	Setting depth h <sub>nom,red</sub> mm	Anchorage depth h <sub>ef,red</sub> mm				
B 6-0-10/57 HCR	01007651	0	6x55	49	40	10	6x45	39	30	57	M6x20	100	1,58
B 6-10-20/67 HCR	01010651	10	6x55	49	40	20	6x45	39	30	67	M6x20	100	1,78
B 6-25-35/82 HCR	01015651	25	6x55	49	40	35	6x45	39	30	82	M6x20	100	2,13
B 6-40-50/97 HCR	01025651	40	6x55	49	40	50	6x45	39	30	97	M6x20	100	2,35

Other length on demand.



**Extract from Permissible Service Conditions of ETA-01/0013 and ETA-06/0155.**

Approved loads for single anchor without influence of spacing and edge distance.

Total safety factor as per ETAG 001 included ( $\gamma_M$  and  $\gamma_F$ ).

Load capacities under fire exposure see page 166.

Loads and performance data			Wedge Anchor BA4 / HCR		M 6		M 8		M 10		M 12		M 16		M 20	
Standard anchorage depth	$h_{ef}$	[mm]	40	-	44	-	48	-	65	-	80	-	100	-	100	-
Reduced anchorage depth	$h_{ef, red}$	[mm]	-	30 <sup>1)</sup>	-	35 <sup>1)</sup>	-	42	-	50	-	64	-	78	-	78
non-cracked concrete																
Mean ultimate loads, tension	C25/30 Num	[kN]	11,0	10,2	19,6	12,4	23,1	17,5	36,4	22,6	53,5	39,7	73,0	53,1	73,0	53,1
Mean ultimate loads, shear	C25/30 Vum	[kN]	9,7	9,7	19,5	19,5	31,9	31,9	42,6	42,6	76,9	76,9	110,4	110,4	110,4	110,4
cracked concrete (multiple use only)																
Approved loads <sup>3)</sup> (any direction)	C20/25 to C50/60 appr. F	[kN]	2,4	1,6	-	-	-	-	-	-	-	-	-	-	-	-
non-cracked concrete																
Approved loads, tension	C20/25 appr. N	[kN]	3,6	2,9	5,7	4,3	7,6	5,7	11,9	8,5	17,2	12,3	24,0	16,6	24,0	16,6
	C25/30 appr. N	[kN]	3,9	3,1	6,3	4,7	8,3	6,3	13,0	9,3	18,8	13,5	26,3	18,1	26,3	18,1
	C30/37 appr. N	[kN]	4,4	3,5	7,0	5,2	9,3	7,0	14,5	10,3	20,9	15,0	29,3	20,2	29,3	20,2
	C40/50 appr. N	[kN]	4,8	4,0	8,1	6,1	10,8	8,1	16,8	12,0	24,3	17,4	34,0	23,4	34,0	23,4
	C50/60 appr. N	[kN]	4,8	4,4	8,6	6,6	11,8	8,9	18,4	13,2	26,7	19,1	37,3	25,7	37,3	25,7
Approved loads, shear	C20/25 appr. V	[kN]	4,0	4,0	6,9	5,0	8,0	6,5	15,4	8,5	28,6	24,6	43,9	33,1	43,9	33,1
	$\geq$ C25/30 appr. V	[kN]	4,0	4,0	6,9	5,5	8,8	7,2	15,4	9,3	28,6	27,0	43,9	36,4	43,9	36,4
Approved bending moments	appr. M	[Nm]	5,7	5,7	13,7	13,7	28,0	28,0	48,6	48,6	113,7	113,7	231,6	231,6	231,6	231,6
Spacing and edge distance																
Effective anchorage depth	$h_{ef}$	[mm]	40	30 <sup>1)</sup>	44	35 <sup>1)</sup>	48	42	65	50	80	64	100	78	100	78
Characteristic spacing	$s_{cr, N}$	[mm]	120/370 <sup>2)</sup>	90/260 <sup>2)</sup>	132	105	144	126	195	150	240	192	300	234	300	234
Characteristic edge distance	$c_{cr, N}$	[mm]	60/185 <sup>2)</sup>	45/130 <sup>2)</sup>	66	52,5	72	63	97,5	75	120	96	150	117	150	117
cracked concrete (multiple use only)																
Minimum spacing	$s_{min}$	[mm]	50	50	-	-	-	-	-	-	-	-	-	-	-	-
Minimum edge distance	$c_{min}$	[mm]	50	50	-	-	-	-	-	-	-	-	-	-	-	-
Minimum thickness of concrete slab	$h_{min}$	[mm]	80	80	-	-	-	-	-	-	-	-	-	-	-	-
non-cracked concrete																
Minimum spacing	$s_{min} / c$	[mm]	35/40	35/40	35/65	60/60	45/70	55/65	60/100	100/100	80/120	110/110	100/150	140/140	100/150	140/140
Minimum edge distance	$c_{min} / s$	[mm]	35/60	40/35	45/110	60/60	55/80	65/55	70/100	100/100	80/140	110/110	100/180	140/140	100/180	140/140
Minimum thickness of concrete slab	$h_{min}$	[mm]	100	80	100	80	100	100	130	100	160	130	200	160	200	160
Installation parameters																
Drill hole diameter	$d_o$	[mm]	6	6	8	8	10	10	12	12	16	16	20	20	20	20
Diameter of clearance hole in the fixture	$d_f$	[mm]	7	7	9	9	12	12	14	14	18	18	22	22	22	22
Depth of drill hole	$h_1$	[mm]	55	45	65	55	70	65	90	75	110	95	130	110	130	110
Installation torque	$T_{inst}$	[Nm]	6/8 <sup>2)</sup>	6/8 <sup>2)</sup>	15	15	25	25	50	50	100	100	160	160	160	160
Width across nut	SW	[mm]	10	10	13	13	17	17	19	19	24	24	30	30	30	30

<sup>1)</sup> Application limited to statically indetermined systems.

<sup>2)</sup> For applications according to ETA-01/0013. / For applications according to ETA-06/0155.

For anchor designing, an easy to operate CD-ROM is available on request or can be downloaded at [www.mkt.de](http://www.mkt.de).

<sup>3)</sup> The maximum load per fixing point for multiple use for non-structural applications may, depending on national regulations, are below the approved load of the anchor. The approved loads per fixing point are regulated for their respective countries in the ETAG 001, Part 6.

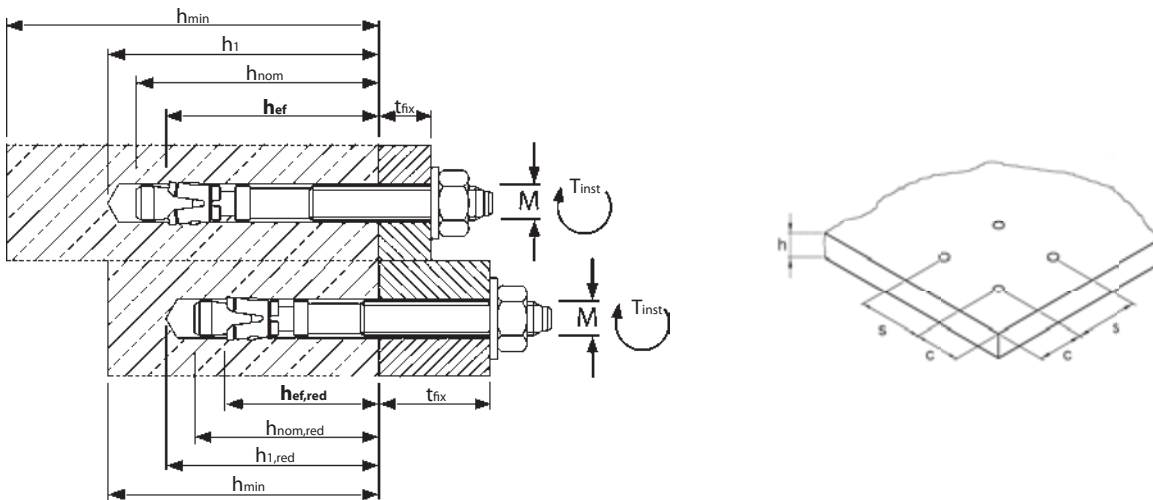

**Installation**

