

Product Range 2018



Wedge Anchor Software Accessories Injection System Chemical Anchor Highload Anchor Wedge Anchor

www.mkt.de



... a solid connection

All technical details may be subject to change without notice.

We do not accept liability for printing mistakes or omissions.

MKT was founded in 1990 as a manufacturer of high-quality, internationally approved fastening systems. In the year 1996 the Quality management system according to ISO 9001 was certified and in the years 2014 and 2015 the environmental management system according to ISO 14001 was added, the energy management system according to ISO 50001 and the occupational health and safety management system according to OHSAS 18001 were established.

In addition to the standard product offering found in our catalog, MKT also supplies anchor sizes and special designs, such as custom solutions for tunnel construction as well as stainless steel anchors made from the materials 1.4529, 1.4571 and 1.4462 and some products with fractional thread.

MKT provides customer service on all technical questions.

NEW:

→ Wedge Anchor BZ plus sh:

The Wedge Anchor BZ plus has been extended by a sheradized version. With a layer thickness larger than 40 µm, the Wedge Anchor BZ plus provides a higher protection against corrosion.

→ Highload Anchor SZ:

The Highload Anchor SZ has been extended by the size SZ 32/M24 in the versions SZ-B, with threaded bolt, and SZ-S, with hexagon head. The Highload Anchor SZ 32/M24 allows highest, approved tension and shear loads within the Mechanical Heavy Duty Anchors.

The new Highload Anchor SZ 32/M24 as anchor type SZ-B with threaded bolt and as anchor type SZ-S with hexagon head screw is a mechanical heavy duty anchor for highest, approved tension and shear loads

→ Highload Anchor SLZ:

The Highload Anchor SLZ is a sleeve anchor with a diameter of 14/M10. Due to its drill hole diameter of 14mm, it is perfectly suited for through setting of shelving systems with clearance holes of 15mm. There are two models available: The hexagon head version and the bolt version with nut.

→ Injection System VMH:

The new Injection System VMH has been developed for extremely high, approved loads in cracked and non-cracked concrete. It is composed of a hybrid injection adhesive as well as the already established metric anchor rods VMU-A, V-A or the internally threaded studs VMU-IG. Threaded studs with manufacturer's certificate 3.1 EN10204 (e.g. MKT VM-A) can also be used for fixation.

The variable anchorage depths of the Injection system VMH allow maximum loads and flexible adaptation to the respective installation situation. The injection system VMH with MKT anchor rods is also approved for loads under seismic action category C1 and C2(M12).

→ Injection system VMU plus and Injection system VME:

The European Technical Assessments Option 1 for the Injection systems VMU plus (ETA-11/0415) and VME (ETA-09/0350) have been extended by the approved usage of internal threaded sleeves in cracked and non-cracked concrete. This allows an even more flexible use of these injection systems. There are 6 dimensions VMU-IG M6 to VMU-IG M10 available from stock.

→ Injection System VM-EA:

The new injection system VM-EA is a styrene-free injection system based on an epoxy acrylate and can be used with the MKT anchor rods VMU-A, VA or with threaded studs with manufacturer's certificate (e.g. MKT VM-A) for fixings in non-cracked concrete and to be used in masonry.

→ Chemical Anchor V plus:

The Chemical Anchor V plus is a further development of the well-proven Chemical Anchor V with higher approved loads. The European Technical Assessment, option 7, allows for further increase of loads in case of higher concrete quality.



Quality Management System
ISO 9001



Environmental Management
System ISO 14001



Energy Management System
ISO 50001



Occupational Health and Safety
Management System
OHSAS 18001



... a solid connection

Anchor Selection

	Mechanical Heavy Duty Anchors																	Chemical Anchors							Light Duty Anchors														
	Wedge Anchor BZ plus / sh	Wedge Anchor BZ plus A4	Wedge Anchor BZ plus HCR	Wedge Anchor BZ-IG	Wedge Anchor BZ-IG A4/HCR	Wedge Anchor B	Wedge Anchor B hot dip gal.	Wedge Anchor B A4	Wedge Anchor B HCR	Wedge Anchor B-IG / B-IG A4	Nail Anchor N, N-K	Nail Anchor N-M	Drop-in Anchor E, ES	Drop-in Anchor E A4 / E HCR	Hollow Core Anchor Easy	Highload Anchor SZ	Highload Anchor SZ A4	Highload Anchor SLZ	Highload Anchor SL	Highload Anchor SL A4	Concrete Screw BSZ	Injection System VMZ	Injection System VMZ-IG	Injection System VMZ dyn	Injection System VMH	Injection System VMU plus	Injection System VM-EA	Injection System VME	Injection Adhesive VM-PY	Chemical Anchor V plus	Chemical Anchor V	Chemical Anchor V-IG	Nail Plug ND	Universal Plug UD	Nylon-Standard-Plug NSD	Safety Nail TDN	Drywall Plug GKD		
Cracked Concrete	•	•	•	•	•											•	•	•			•	•	•	•	•	•	•	•	•										
Non-cracked Concrete	•	•	•	•	•	•	•	•		•			•	•		•	•	•	•	•	•	•	•	•	•	•	•	•	•	•	•	•	•	•	•	•	•	•	
Multiple Use in Concrete								•	•		•	•	•	•							•																•		
Pre-stressed Concrete Hollow Slabs															•																								
Hollow Brick																										•	•									•			
Solid Brick																										•	•	•	•	•						•			
Autoclaved aerated concrete																										•	•									•			
Drywall																																					•		
ETA Approval	•	•	•	•	•	•	•	•	•		•	•	•	•		•	•	•	•			•	•		•	•	•	•	•	•	•	•				•			
DIBT Approval															•									•		•	•	•	•										
Fire Resistant	• ¹⁾	•	•	•	•	•	•	•	•		•	•	•	•	•	•	•				•		•	•	•	•	•	•	•	•	•				•				
Fire Resistant in Tunnels			•								•											•	•																
ICC Approval																•												•											
Approved for fatigue loading																								•															
Approved for seismic action	•	•	•													•	•				•			•	•		•												
VdS	•	•	•	•	•							•	•	•	•	•	•																						
FM	•	•	•			•		•					•	•																									
Swiss Shock Approval	•	•	•	•	•											•	•						•																
Steel, Zinc Plated	•			•		•				•	•	•	•	•	•	•		•	•			•	•	•	•	•	•	•	•	•	•	•	•	•	•	•	•		
Steel, Hot Dip Galvanized							•																																
Stainless Steel A4/316		•			•			•		•	•		•	•			•					•	•	•	•	•	•	•	•	•	•	•	•	•	•	•	•		
Stainless Steel HCR, 1.4529			•		•			•		•	•		•	•			•					•	•	•	•	•	•	•	•	•	•	•	•	•	•	•	•		
Hollow drill bit	•	•	•	•	•							• ²⁾	• ²⁾	•	•	•	•				•	•	•	•	•	•	•	•	•	•	•	•	•	•	•	•			
Design Software available	•	•	•	•	•	•	•	•	•	•		•	•			•	•				•	•	•	•	•	•	•	•	•	•	•	•	•	•	•	•			

¹⁾Not for sherardized Wedge anchor BZ plus sh

²⁾Only for multiple use for non-structural applications

Table of Contents

Mechanical Heavy Duty Anchors

Wedge Anchor BZ plus / BZ plus sh / BZ-U plus / BZ-UH plus	8 - 11
Wedge Anchor BZ plus A4 / BZ-U plus A4	12-15
Wedge Anchor BZ plus HCR / BZ-U plus HCR	16-18
Wedge Anchor BZ-IG / BZ-IG A4 / BZ-IG HCR	19-24
Wedge Anchor B / B-U / B A4 / B HCR / B hot dip galv.	26-34
Wedge Anchor B-W	35
Wedge Anchor B-IG / B-IG A4	36-37
Nail Anchor N / N-K / N-M	38-41
Drop-in Anchor E / ES / ED / E A4 / E HCR	42-51
Hollow Core Anchor Easy	52-53
Highload Anchor SZ / SZ A4	54-59
Highload Anchor SLZ	60-61
Highload Anchor SL / SL A4	62-63
Concrete screw BSZ / BSZ A4	64-76

Chemical Anchors

Injection System VMZ / VMZ A4 / VMZ HCR	80-89
Injection System VMZ-IG / VMZ-IG A4	90-92
Injection System VMZ dynamic	93-97
Injection System VMH	98-103
Injection System VMU plus / VMU plus Polar	104-118
Injection System VM-EA	119-128
Injection System VME	129-137
Injection System VM-PY	138-139
Accessories for Injection Systems	140-142
Chemical Anchor V plus / V / V A4 / V HCR	143-150
Chemical Anchor V-IG / V-IG A4	151-152
Hollow drill bit SB / Suction bell ASG	153

Light Duty Anchors

Nail Plug ND	156
Universal Plug UD	157
Nylon-Standard-Plug NSD	158
Safety Nail TDN	159
Drywall Plug GKD	160

Service

Design Software	164-165
Fire Resistance Reports	166-169



Approvals and Certificates



Certification according to ISO 9001, ISO 14001, ISO 50001 and OHSAS 18001.



European Technical Approval/Assessment (ETA) with CE marking



Approval by ‚Deutsches Institut für Bautechnik‘ in Berlin, Germany



ICC Evaluation Service listing, USA.



Shock approval by ‚Bundesamt für Bevölkerungsschutz‘ in Bern, Switzerland.



Factory Mutual (FM), U.S. approval for installation of sprinkler systems



Suitable for installation of sprinkler systems as per requirements of VdS Schadenverhütung GmbH, Germany



VdS Schadenverhütung GmbH, Germany, approval for installation of sprinkler systems



Fire resistance tested according to standard temperature curve considering DIN EN 1363-1 and in dependence of TR 020. For anchors not suitable for tension zones, it has to be verified and assessed depending on the design situation if the design method stated in TR 020 can be applied. See also page 166-168.



Tested according to ZTV-tunnel temperature curve. See also page 169.



Tested according to RWS-tunnel temperature curve.



Identifies anchors that are approved for fatigue loading



Identifies anchors suitable for use under seismic loading



Material sign for stainless steel (A4 grade 316 or HCR material 1.4529)



NSF International certification for use in drinking water and food systems..



Indicate the emission-class after the French directive (No. 2011-321 from 2011/03/23) on the labeling of building products for their indoor air emissions. The emissions are rated on a scale of A+ (very low emissions) to C (high emissions).



EPD-Environmental Product Declaration according ISO 14025 and EN 15804 by the Institut Bauen und Umwelt e.V. (IBU).



Indicates the anchors for which further steps of cleaning after the bore hole drilling can be omitted due to the usage of the Hollow drill bit SB.



Included in MKT Design-Software

Mechanical Heavy Duty Anchors



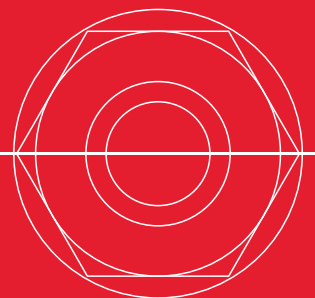

Wedge Anchor BZ plus

Steel, zinc plated



Wedge Anchor BZ plus s



Wedge Anchor BZ plus



Wedge Anchor BZ-U plus / Wedge Anchor BZ-UH plus



Wedge Anchor BZ plus M24/M27

Range of Loading: 2,4 kN - 96,8 kN
Range of concrete quality: C20/25 - C50/60

Description

There has been further improvement to the performance and application range of the wedge anchor BZ plus. The new European Technical Assessment replaces the previous European technical approval. Now its suitability has been verified for seismic loading, performance categories C1 and C2. Variants include a second effective anchorage depth, longer thread, and new sizes with a shorter overall length and only one effective anchorage depth.

The new sherardized Wedge anchor BZ plus sh with a layer thickness larger than 40 µm provides a higher protection against corrosion.

For timber structures, the BZ-UH plus variant is also available with the DIN EN ISO 7094 (DIN 440) washer.

Advantages

- Approved under the building regulations with a new European Technical Assessment (Option 1)
- Approved for use in cracked and non-cracked concrete
- Approved for seismic loads, performance categories C1 and C2 (M8 to M20, maximum anchor length 210 mm)
- Approved for use under fire exposure. Fire resistance ratings R30-R120²⁾
- Suitable for use in compression resistant natural stone (without approval)
- Two effective anchorage depths for greater flexibility (M8 to M16, maximum anchor length 210 mm)
- Anchoring with shorter effective anchorage depth reduces drilling and installation time.
- Anchoring with the standard effective anchorage depth is suitable for the highest load limits

¹⁾Only standard anchorage depth
²⁾Not for sherardized Wedge anchor BZ plus sh



Approvals and Certificates



- Particularly cost effective: the short "s" versions with only one effective anchorage depth in the sizes M8 to M16
- Suitable for surface, through, and stand-off fastening
- Suitable for sprinkler system installations complying with VdS requirements
- FM approval for the installation of sprinkler systems (M10 to M16)
- Shock approval by the Swiss Federal Office for Civil Protection

Applications

Medium to heavy duty anchoring in cracked and non-cracked concrete: Steel beams, base plates, channels, tracks, wood structures.

Example of Installation

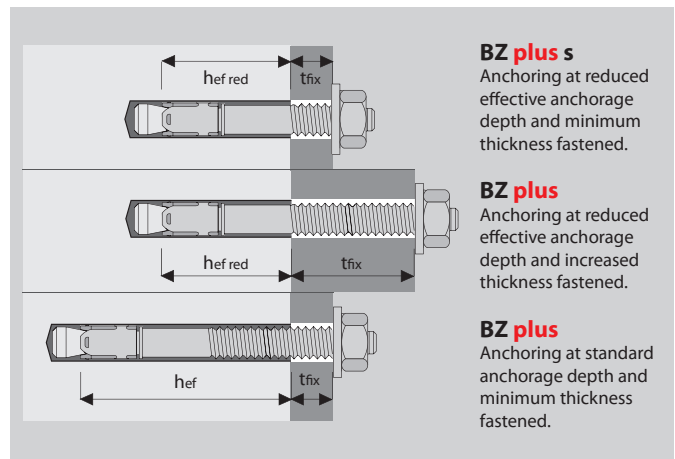

Wedge Anchor BZ plus



→ Steel, zinc plated

→ Approved for cracked and non-cracked concrete

Description	Ref. No.	Standard anchorage depth					Reduced anchorage depth					Anchor length	Thread	Pkg. content	Weight per pkg.
		max. Fixture thickness t _{fix} mm	Drill hole Ø x depth mm	Setting depth h _{nom} mm	Anchorage depth h _{ef} mm	Seismic C1 / C2	max. Fixture thickness t _{fix,red} mm	Drill hole Ø x depth mm	Setting depth h _{nom,red} mm	Anchorage depth h _{ef,red} mm					
BZ 8-6/60 s	06105001	-	-	-	-	- / -	6	8x49	41	35	60	M8x16	100	2,54	
BZ 8-11/65 s	06110001	-	-	-	-	- / -	11	8x49	41	35	65	M8x22	100	2,69	
BZ 8-10-21/75	06115001	10	8x60	52	46	✓ / ✓	21	8x49	41	35	75	M8x32	100	2,99	
BZ 8-15-26/80	06125001	15	8x60	52	46	✓ / ✓	26	8x49	41	35	80	M8x37	100	3,14	
BZ 8-30-41/95	06140001	30	8x60	52	46	✓ / ✓	41	8x49	41	35	95	M8x52	100	3,60	
BZ 8-50-61/115	06150001	50	8x60	52	46	✓ / ✓	61	8x49	41	35	115	M8x72	100	4,24	
BZ 8-100-111/165	06170001	100	8x60	52	46	✓ / ✓	111	8x49	41	35	165	M8x122	50	2,94	
BZ 10-10/70 s	06205001	-	-	-	-	- / -	10	10x55	48	40	70	M10x22	50	2,44	
BZ 10-20/80 s	06210001	-	-	-	-	- / -	20	10x55	48	40	80	M10x32	50	2,69	
BZ 10-10-30/90	06215001	10	10x75	68	60	✓ / ✓	30	10x55	48	40	90	M10x42	50	2,94	
BZ 10-15-35/95	06220001	15	10x75	68	60	✓ / ✓	35	10x55	48	40	95	M10x47	50	3,06	
BZ 10-20-40/100	06225001	20	10x75	68	60	✓ / ✓	40	10x55	48	40	100	M10x52	50	3,18	
BZ 10-30-50/110	06230001	30	10x75	68	60	✓ / ✓	50	10x55	48	40	110	M10x62	50	3,44	
BZ 10-50-70/130	06235001	50	10x75	68	60	✓ / ✓	70	10x55	48	40	130	M10x82	50	3,95	
BZ 10-75-95/155	06250001	75	10x75	68	60	✓ / ✓	95	10x55	48	40	155	M10x107	50	4,55	
BZ 10-100-120/180	06260001	100	10x75	68	60	✓ / ✓	120	10x55	48	40	180	M10x132	50	5,16	
BZ 10-150/230	06270001	150	10x75	68	60	- / -	-	-	-	-	230	M10x80	25	3,49	
BZ 12-10/85 s	06305001	-	-	-	-	- / -	10	12x70	60	50	85	M12x26	25	2,10	
BZ 12-20/95 s	06310001	-	-	-	-	- / -	20	12x70	60	50	95	M12x36	25	2,28	
BZ 12-10-30/105	06313001	10	12x90	80	70	✓ / ✓	30	12x70	60	50	105	M12x46	25	2,49	
BZ 12-15-35/110	06315001	15	12x90	80	70	✓ / ✓	35	12x70	60	50	110	M12x51	25	2,55	
BZ 12-20-40/115	06320001	20	12x90	80	70	✓ / ✓	40	12x70	60	50	115	M12x56	25	2,66	
BZ 12-30-50/125	06325001	30	12x90	80	70	✓ / ✓	50	12x70	60	50	125	M12x66	25	2,84	
BZ 12-50-70/145	06330001	50	12x90	80	70	✓ / ✓	70	12x70	60	50	145	M12x86	25	3,23	
BZ 12-65-85/160	06335001	65	12x90	80	70	✓ / ✓	85	12x70	60	50	160	M12x101	25	3,49	
BZ 12-85-105/180	06340001	85	12x90	80	70	✓ / ✓	105	12x70	60	50	180	M12x121	25	3,84	
BZ 12-105-125/200	06345001	105	12x90	80	70	✓ / ✓	125	12x70	60	50	200	M12x141	25	4,21	
BZ 12-125/220	06350001	125	12x90	80	70	- / -	-	-	-	-	220	M12x80	25	4,93	
BZ 12-145/240	06355001	145	12x90	80	70	- / -	-	-	-	-	240	M12x80	20	4,32	
BZ 12-160/255	06360001	160	12x90	80	70	- / -	-	-	-	-	255	M12x80	20	4,59	
BZ 12-190/285	06370001	190	12x90	80	70	- / -	-	-	-	-	285	M12x80	20	4,99	
BZ 16-5/105 s	06505001	-	-	-	-	- / -	5	16x90	77	65	105	M16x26	20	3,48	
BZ 16-15/115 s	06510001	-	-	-	-	- / -	15	16x90	77	65	115	M16x36	20	3,76	
BZ 16-15-35/135	06520001	15	16x110	97	85	✓ / ✓	35	16x90	77	65	135	M16x56	20	4,32	
BZ 16-25-45/145	06525001	25	16x110	97	85	✓ / ✓	45	16x90	77	65	145	M16x66	20	4,60	
BZ 16-50-70/170	06530001	50	16x110	97	85	✓ / ✓	70	16x90	77	65	170	M16x91	20	5,26	
BZ 16-80-100/200	06535001	80	16x110	97	85	✓ / ✓	100	16x90	77	65	200	M16x121	10	3,20	
BZ 16-100/220	06540001	100	16x110	97	85	- / -	-	-	-	-	220	M16x80	10	3,50	
BZ 16-140/260	06550001	140	16x110	97	85	- / -	-	-	-	-	260	M16x80	10	4,12	
BZ 16-180/300	06560001	180	16x110	97	85	- / -	-	-	-	-	300	M16x80	10	4,74	
BZ 20-30/165	06615101	30	20x125	114	100	✓ / ✓	-	-	-	-	165	M20x50	10	4,41	
BZ 20-60/195	06625101	60	20x125	114	100	✓ / ✓	-	-	-	-	195	M20x70	10	5,05	
BZ 20-100/235	06630101	100	20x125	114	100	- / -	-	-	-	-	235	M20x80	5	3,04	
BZ 20-130/265	06635101	130	20x125	114	100	- / -	-	-	-	-	265	M20x80	5	3,43	
BZ 20-150/285	06640101	150	20x125	114	100	- / -	-	-	-	-	285	M20x80	5	3,66	
BZ 24-30/190	06715101	30	24x145	133	115	- / -	-	-	-	-	190	M24x55	10	6,85	
BZ 24-60/220	06725101	60	24x145	133	115	- / -	-	-	-	-	220	M24x85	5	3,93	
BZ 24-75/235	06735101	75	24x145	133	115	- / -	-	-	-	-	235	M24x100	5	4,15	
BZ 24-100/260	06745101	100	24x145	133	115	- / -	-	-	-	-	260	M24x125	5	4,52	
BZ 27-30/210	06815101	30	28x160	146	125	- / -	-	-	-	-	210	M27x62	5	5,10	
BZ 27-60/240	06825101	60	28x160	146	125	- / -	-	-	-	-	240	M27x92	5	5,60	
BZ 27-100/280	06845101	100	28x160	146	125	- / -	-	-	-	-	280	M27x132	5	6,40	

Other lengths on demand.

Wedge Anchor BZ plus sh

→ Steel sherardized



→ Approved for cracked and non-cracked concrete

NEW

Description	Ref. No.	Standard anchorage depth					Reduced anchorage depth					Anchor length	Thread	Pkg. content pcs.	Weight per pkg. kg
		max. Fixture thickness t _{fix} mm	Drill hole Ø x depth mm	Setting depth h _{nom} mm	Anchorage depth h _{ef} mm	Seismic C1 / C2	max. Fixture thickness t _{fix,red} mm	Drill hole Ø x depth mm	Setting depth h _{nom,red} mm	Anchorage depth h _{ef,red} mm					
BZ 10-10-30/90 sh	06215601	10	10x75	68	60	✓ / ✓	30	10x55	48	40	90	M10x42	50	2,94	
BZ 10-20-40/100 sh	06225601	20	10x75	68	60	✓ / ✓	40	10x55	48	40	100	M10x52	50	3,18	
BZ 10-30-50/110 sh	06230601	30	10x75	68	60	✓ / ✓	50	10x55	48	40	110	M10x62	50	3,44	
BZ 12-15-35/110 sh	06315601	15	12x90	80	70	✓ / ✓	35	12x70	60	50	110	M12x51	25	2,55	
BZ 12-30-50/125 sh	06325601	30	12x90	80	70	✓ / ✓	50	12x70	60	50	125	M12x66	25	2,84	
BZ 16-25-45/145 sh	06525601	25	16x110	97	85	✓ / ✓	45	16x90	77	65	145	M16x66	20	4,60	

Other dimensions on demand.

Wedge Anchor BZ-U plus

→ Steel, zinc plated



→ With large washer DIN EN ISO 7093-1 (DIN 9021), preassembled

→ Approved for cracked and non-cracked concrete

Description	Ref. No.	Standard anchorage depth					Reduced anchorage depth					Anchor length	Thread	Washer ¹⁾	Pkg. content pcs.	Weight per pkg. kg
		max. Fixture thickness t _{fix} mm	Drill hole Ø x depth mm	Setting depth h _{nom} mm	Anchorage depth h _{ef} mm	Seismic C1 / C2	max. Fixture thickness t _{fix,red} mm	Drill hole Ø x depth mm	Setting depth h _{nom,red} mm	Anchorage depth h _{ef,red} mm						
BZ-U 8-10-21/75	06115301	10	8x60	52	46	✓ / ✓	21	8x49	41	35	75	M8x32	24x2	100	3,46	
BZ-U 8-15-26/80	06125301	15	8x60	52	46	✓ / ✓	26	8x49	41	35	80	M8x37	24x2	100	3,52	
BZ-U 8-30-41/95	06140301	30	8x60	52	46	✓ / ✓	41	8x49	41	35	95	M8x52	24x2	100	4,01	
BZ-U 10-10-30/90	06215301	10	10x75	68	60	✓ / ✓	30	10x55	48	40	90	M10x42	30x2,5	50	3,30	
BZ-U 10-15-35/95	06220301	15	10x75	68	60	✓ / ✓	35	10x55	48	40	95	M10x47	30x2,5	50	3,45	
BZ-U 10-30-50/110	06230301	30	10x75	68	60	✓ / ✓	50	10x55	48	40	110	M10x62	30x2,5	50	3,95	
BZ-U 10-50-70/130	06235301	50	10x75	68	60	✓ / ✓	70	10x55	48	40	130	M10x82	30x2,5	50	4,31	
BZ-U 10-100-120/180	06260301	100	10x75	68	60	✓ / ✓	120	10x55	48	40	180	M10x132	30x2,5	50	6,02	
BZ-U 10-150/230	06270301	150	10x75	68	60	- / -	-	-	-	-	230	M10x80	30x2,5	25	3,73	
BZ-U 12-15-35/110	06315301	15	12x90	80	70	✓ / ✓	35	12x70	60	50	110	M12x51	37x3	25	2,86	
BZ-U 12-30-50/125	06325301	30	12x90	80	70	✓ / ✓	50	12x70	60	50	125	M12x66	37x3	25	3,26	
BZ-U 12-50-70/145	06330301	50	12x90	80	70	✓ / ✓	70	12x70	60	50	145	M12x86	37x3	25	3,68	
BZ-U 12-105-125/200	06345301	105	12x90	80	70	✓ / ✓	125	12x70	60	50	200	M12x141	37x3	25	4,21	
BZ-U 12-125/220	06350301	125	12x90	80	70	- / -	-	-	-	-	220	M12x80	37x3	25	5,47	
BZ-U 12-145/240	06355301	145	12x90	80	70	- / -	-	-	-	-	240	M12x80	37x3	20	4,50	
BZ-U 12-160/255	06360301	160	12x90	80	70	- / -	-	-	-	-	255	M12x80	37x3	20	4,91	
BZ-U 12-190/285	06370301	190	12x90	80	70	- / -	-	-	-	-	285	M12x80	37x3	20	5,50	
BZ-U 12-230/325	06380301	230	12x90	80	70	- / -	-	-	-	-	325	M12x80	37x3	20	6,12	
BZ-U 16-25-45/145	06525301	25	16x110	97	85	✓ / ✓	45	16x90	77	65	145	M16x66	50x3	20	5,15	
BZ-U 16-50-70/170	06530301	50	16x110	97	85	✓ / ✓	70	16x90	77	65	170	M16x91	50x3	20	5,76	

¹⁾Outer diameter x thickness

Other lengths on demand.

Wedge Anchor BZ-UH plus

→ Steel, zinc plated



→ With large washer DIN EN ISO 7094 (DIN 440)

→ Approved for cracked and non-cracked concrete

NEW

Description	Ref. No.	Standard anchorage depth					Reduced anchorage depth					Anchor length	Thread	Washer ¹⁾	Pkg. content pcs.	Weight per pkg. kg
		max. Fixture thickness t _{fix} mm	Drill hole Ø x depth mm	Setting depth h _{nom} mm	Anchorage depth h _{ef} mm	Seismic C1 / C2	max. Fixture thickness t _{fix,red} mm	Drill hole Ø x depth mm	Setting depth h _{nom,red} mm	Anchorage depth h _{ef,red} mm						
BZ-UH 12-85-105/180	06340401	85	12x90	80	70	✓ / ✓	105	12x70	60	50	180	M12x121	44x4	25	4,60	
BZ-UH 12-105-125/200	06345401	105	12x90	80	70	✓ / ✓	125	12x70	60	50	200	M12x141	44x4	25	4,95	
BZ-UH 12-125/220	06350401	125	12x90	80	70	- / -	-	-	-	-	220	M12x80	44x4	25	5,77	
BZ-UH 12-145/240	06355401	145	12x90	80	70	- / -	-	-	-	-	240	M12x80	44x4	20	4,97	
BZ-UH 12-160/255	06360401	160	12x90	80	70	- / -	-	-	-	-	255	M12x80	44x4	20	5,23	
BZ-UH 12-190/285	06370401	190	12x90	80	70	- / -	-	-	-	-	285	M12x80	44x4	20	5,64	
BZ-UH 12-230/325	06380401	230	12x90	80	70	- / -	-	-	-	-	325	M12x80	44x4	20	6,19	
BZ-UH 12-260/355	06385401	260	12x90	80	70	- / -	-	-	-	-	355	M12x80	44x4	20	6,60	
BZ-UH 16-100/220	06540401	100	16x110	97	85	- / -	-	-	-	-	220	M16x80	56x5	10	4,18	
BZ-UH 16-140/260	06550401	140	16x110	97	85	- / -	-	-	-	-	260	M16x80	56x5	10	4,79	
BZ-UH 16-180/300	06560401	180	16x110	97	85	- / -	-	-	-	-	300	M16x80	56x5	10	5,39	

¹⁾Outer diameter x thickness

Other lengths on demand.



Extract from Permissible Service Conditions of European Technical Assessment ETA-99/0010

Approved loads for single anchor without influence of spacing and edge distance.

Total safety factor as per ETAG 001 included (γ_M and γ_P).

Load capacities under fire exposure see page 166.

Loads and performance data		Wedge Anchor BZ plus	M8	M10	M12	M16	M20	M24	M27			
Standard anchorage depth	h_{ef} [mm]	46	-	60	-	70	-	85	-	100	115	125
Reduced anchorage depth	$h_{ef, red}$ [mm]	-	35	-	40	-	50	-	65	-	-	-
cracked concrete												
Mean ultimate loads, tension	C25/30 Num [kN]	10,5	8,8	14,9	12,4	28,1	17,6	35,5	30,1	54,3	79,8	80,0
Mean ultimate loads, shear	C25/30 V_{um} [kN]	16,4	14,5	24,2	24,0	38,4	36,1	65,1	60,0	89,0	131,8	181,7
Approved loads, tension	C20/25 appr. N [kN]	2,4	2,4	4,3	3,6	7,6	6,1	11,9	9,0	17,1	21,1	24,0
	C25/30 appr. N [kN]	2,6	2,6	4,7	3,9	8,3	6,6	13,0	9,8	18,8	23,2	26,2
	C30/37 appr. N [kN]	2,9	2,9	5,2	4,3	9,3	7,4	14,5	10,9	20,9	25,7	29,1
	C40/50 appr. N [kN]	3,4	3,4	6,1	5,1	10,8	8,6	16,8	12,7	24,2	29,9	33,9
	C50/60 appr. N [kN]	3,7	3,7	6,6	5,5	11,8	9,4	18,4	13,9	26,6	32,8	37,1
non-cracked concrete												
Approved loads, tension	C20/25 appr. N [kN]	5,7	3,6	7,6	4,3	11,9	8,5	16,7	12,6	24,0	29,7	33,6
	C25/30 appr. N [kN]	6,3	3,9	8,3	4,7	13,0	9,3	18,3	13,8	26,3	32,5	36,8
	C30/37 appr. N [kN]	7,0	4,3	9,3	5,2	14,5	10,3	20,3	15,3	29,3	36,1	40,9
	C40/50 appr. N [kN]	7,5	5,1	10,8	6,1	16,8	12,0	23,6	17,8	34,0	41,9	47,5
cracked / non-cracked concrete												
Approved loads, shear	C20/25 appr. V [kN]	7,0	7,0	11,5	10,4/11,5	17,1	14,5/17,1	31,4	21,6/30,2	37,1	59,2/65,1	67,1/94,1
	\geq C25/30 appr. V [kN]	7,0	7,0	11,5	11,4/11,5	17,1	15,9/17,1	31,4	23,6/31,4	37,1	64,8/65,1	73,5/96,8
Approved bending moments	appr. M [Nm]	13,1	13,1	26,9	26,9	46,9	46,9	123,4	123,4	195,0	513,1	760,9

Spacing and edge distance

Effective anchorage depth	h_{ef} [mm]	46	35	60	40	70	50	85	65	100	115	125
Characteristic spacing	$s_{cr, N}$ [mm]	138	105	180	120	210	150	255	195	300	345	375
Characteristic edge distance	$c_{cr, N}$ [mm]	69	52,5	90	60	105	75	127,5	97,5	150	172,5	187,5

Minimum spacing and edge distance for standard thickness of concrete member

cracked concrete												
Standard thickness of concrete slab	$h_{min,1}$ [mm]	100	-	120	-	140	-	170	-	200	230	250
Minimum spacing / for edge distance c	s_{min} / c [mm]	40/70	-	45/70	-	60/100	-	60/100	-	95/150	100/180	125/300
Minimum edge distance / for spacing s	c_{min} / s [mm]	40/80	-	45/90	-	60/140	-	60/180	-	95/200	100/220	180/540
non-cracked concrete												
Minimum spacing / for edge distance c	s_{min} / c [mm]	40/80	-	45/70	-	60/120	-	65/120	-	90/180	100/180	125/300
Minimum edge distance / for spacing s	c_{min} / s [mm]	50/100	-	50/100	-	75/150	-	80/150	-	130/240	100/220	180/540

Minimum spacing and edge distance for minimum thickness of concrete member

cracked concrete												
Minimum thickness of concrete slab	$h_{min,2} / h_{min,3}$ [mm]	80	80	100	80	120	100	140	140	-	-	-
Minimum spacing / for edge distance c	s_{min} / c [mm]	40/70	50/60	45/90	50/100	60/100	50/160	70/160	65/170	-	-	-
Minimum edge distance / for spacing s	c_{min} / s [mm]	40/80	40/185	50/115	65/180	60/140	65/250	80/180	100/250	-	-	-
non-cracked concrete												
Minimum spacing / for edge distance c	s_{min} / c [mm]	40/80	50/60	60/140	50/100	60/120	50/160	80/180	65/170	-	-	-
Minimum edge distance / for spacing s	c_{min} / s [mm]	50/100	40/185	90/140	65/180	75/150	100/185	90/200	170/65	-	-	-

Installation parameters

Drill hole diameter	d_o [mm]	8	8	10	10	12	12	16	16	20	24	28
Diameter of clearance hole in the fixture	d_f [mm]	9	9	12	12	14	14	18	18	22	26	30
Depth of drill hole	h_1 [mm]	60	49	75	55	90	70	110	90	125	145	160
Installation torque, steel galvanized	T_{inst} [Nm]	20	20	25	25	45	45	90	90	160	200	300
Installation torque, steel sherardized	T_{inst} [Nm]	-	-	22	22	40	40	90	90	160	-	-
Width across nut	SW [mm]	13	13	17	17	19	19	24	24	30	36	41

For anchor designing, an easy to operate CD-ROM is available on request or can be downloaded at www.mkt.de

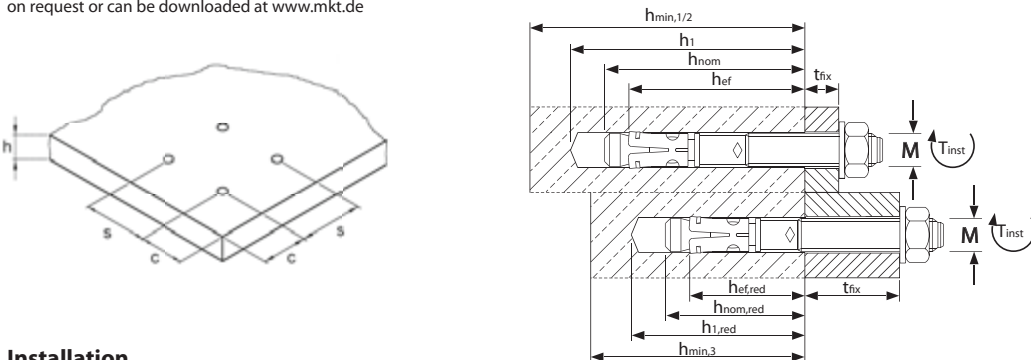

Installation

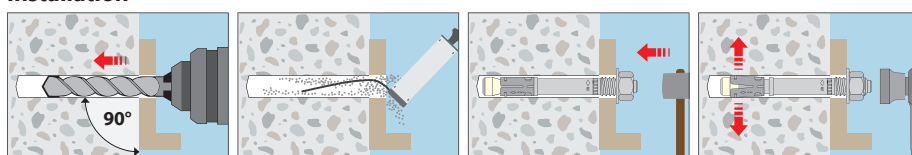

Wedge Anchor BZ plus A4

Stainless steel A4/316



Wedge Anchor
BZ plus s A4



Wedge Anchor
BZ plus A4



Wedge Anchor
BZ-U plus A4



Wedge Anchor
BZ plus A4 M24

Range of Loading: 2,4 kN - 70,6 kN

Range of concrete quality: C20/25 - C50/60



Approvals and Certificates



Description

There has been further improvement to the performance and application range of the wedge anchor BZ plus A4. The new European Technical Assessment replaces the previous European technical approval. Now its suitability has been verified for seismic loading, performance categories C1 and C2. Variants include a second effective anchorage depth, longer thread, and new sizes with a shorter overall length and only the one effective anchorage depth.

Advantages

- Approved under the building regulations with a new European Technical Assessment (Option 1)
- Approved for use in cracked and non-cracked concrete
- Approved for use under seismic loading, performance categories C1 and C2 (M8 to M20, maximum anchor length 210 mm)
- Approved for use under fire exposure. Fire resistance ratings R30-R120
- Suitable for use in compression resistant natural stone (without approval)
- Two effective anchorage depths for greater flexibility (M8 to M16, maximum anchor length 210 mm)
- Anchoring with the smaller effective anchorage depth reduces drilling and installation time.
- Anchoring with the standard effective anchorage depth is suitable for the highest load limits
- Particularly cost effective: the short "s" versions with only one effective anchorage depth in the sizes M8 to M16
- Suitable for surface, through, and stand-off fastening
- Suitable for sprinkler system installations complying with VdS requirements
- FM approval for the installation of sprinkler systems (M10 to M16)
- Shock approval by the Swiss Federal Office for Civil Protection

Applications

Medium to heavy duty anchoring in cracked and non-cracked concrete: Steel beams, channels, facade substructures, stadium seating, wood structures.

Example of Installation

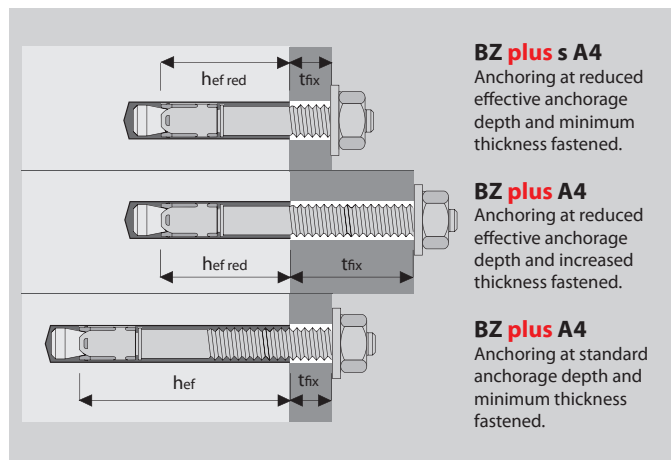

¹⁾Only standard anchorage depth

Wedge Anchor BZ plus A4

→ Stainless steel A4/316



→ Approved for cracked and non-cracked concrete

Description	Ref. No.	Standard anchorage depth					Reduced anchorage depth				Anchor length	Thread	Pkg. content	Weight per pkg.
		max. Fixture thickness t _{fix} mm	Drill hole Ø x depth mm	Setting depth h _{nom} mm	Anchorage depth h _{ef} mm	Seismic C1 / C2	max. Fixture thickness t _{fix,red} mm	Drill hole Ø x depth mm	Setting depth h _{nom,red} mm	Anchorage depth h _{ef,red} mm				
BZ 8-6/60 s A4	02105001	-	-	-	-	- / -	6	8x49	41	35	60	M8x16	100	2,54
BZ 8-11/65 s A4	02110001	-	-	-	-	- / -	11	8x49	41	35	65	M8x22	100	2,69
BZ 8-10-21/75 A4	02115001	10	8x60	52	46	✓ / ✓	21	8x49	41	35	75	M8x32	100	2,99
BZ 8-15-26/80 A4	02125001	15	8x60	52	46	✓ / ✓	26	8x49	41	35	80	M8x37	100	3,14
BZ 8-30-41/95 A4	02140001	30	8x60	52	46	✓ / ✓	41	8x49	41	35	95	M8x52	100	3,60
BZ 8-50-61/115 A4	02150001	50	8x60	52	46	✓ / ✓	61	8x49	41	35	115	M8x72	100	4,24
BZ 8-100-111/165 A4	02170001	100	8x60	52	46	✓ / ✓	111	8x49	41	35	165	M8x122	50	2,94
BZ 10-10/70 s A4	02205001	-	-	-	-	- / -	10	10x55	48	40	70	M10x22	50	2,44
BZ 10-20/80 s A4	02210001	-	-	-	-	- / -	20	10x55	48	40	80	M10x32	50	2,69
BZ 10-10-30/90 A4	02215001	10	10x75	68	60	✓ / ✓	30	10x55	48	40	90	M10x42	50	2,94
BZ 10-15-35/95 A4	02220001	15	10x75	68	60	✓ / ✓	35	10x55	48	40	95	M10x47	50	3,06
BZ 10-20-40/100 A4	02225001	20	10x75	68	60	✓ / ✓	40	10x55	48	40	100	M10x52	50	3,18
BZ 10-30-50/110 A4	02230001	30	10x75	68	60	✓ / ✓	50	10x55	48	40	110	M10x62	50	3,44
BZ 10-50-70/130 A4	02235001	50	10x75	68	60	✓ / ✓	70	10x55	48	40	130	M10x82	50	3,95
BZ 10-75-95/155 A4	02250001	75	10x75	68	60	✓ / ✓	95	10x55	48	40	155	M10x107	50	4,55
BZ 10-100-120/180 A4	02260001	100	10x75	68	60	✓ / ✓	120	10x55	48	40	180	M10x132	50	5,16
BZ 10-150/230 A4	02270001	150	10x75	68	60	- / -	-	-	-	-	230	M10x80	25	3,49
BZ 12-10/85 s A4	02305001	-	-	-	-	- / -	10	12x70	60	50	85	M12x26	25	2,10
BZ 12-20/95 s A4	02310001	-	-	-	-	- / -	20	12x70	60	50	95	M12x36	25	2,28
BZ 12-10-30/105 A4	02313001	10	12x90	80	70	✓ / ✓	30	12x70	60	50	105	M12x46	25	3,48
BZ 12-15-35/110 A4	02315001	15	12x90	80	70	✓ / ✓	35	12x70	60	50	110	M12x51	25	2,55
BZ 12-20-40/115 A4	02320001	20	12x90	80	70	✓ / ✓	40	12x70	60	50	115	M12x56	25	2,66
BZ 12-30-50/125 A4	02325001	30	12x90	80	70	✓ / ✓	50	12x70	60	50	125	M12x66	25	2,84
BZ 12-50-70/145 A4	02330001	50	12x90	80	70	✓ / ✓	70	12x70	60	50	145	M12x86	25	3,23
BZ 12-65-85/160 A4	02335001	65	12x90	80	70	✓ / ✓	85	12x70	60	50	160	M12x101	25	3,48
BZ 12-85-105/180 A4	02340001	85	12x90	80	70	✓ / ✓	105	12x70	60	50	180	M12x121	25	3,84
BZ 12-105-125/200 A4	02345001	105	12x90	80	70	✓ / ✓	125	12x70	60	50	200	M12x141	25	4,21
BZ 12-125/220 A4	02350001	125	12x90	80	70	- / -	-	-	-	-	220	M12x80	25	4,93
BZ 12-160/255 A4	02360001	160	12x90	80	70	- / -	-	-	-	-	255	M12x80	20	4,59
BZ 12-190/285 A4	02370001	190	12x90	80	70	- / -	-	-	-	-	285	M12x80	20	4,99
BZ 12-230/325 A4	02380001	230	12x90	80	70	- / -	-	-	-	-	325	M12x80	20	5,84
BZ 16-15/115 s A4	02510001	-	-	-	-	- / -	15	16x90	77	65	115	M16x36	20	3,76
BZ 16-5-25/125 A4	02515001	5	16x110	97	85	✓ / ✓	25	16x90	77	65	125	M16x46	20	4,15
BZ 16-15-35/135 A4	02520001	15	16x110	97	85	✓ / ✓	35	16x90	77	65	135	M16x56	20	4,32
BZ 16-25-45/145 A4	02525001	25	16x110	97	85	✓ / ✓	45	16x90	77	65	145	M16x66	20	4,68
BZ 16-50-70/170 A4	02530001	50	16x110	97	85	✓ / ✓	70	16x90	77	65	170	M16x91	20	5,36
BZ 16-80-100/200 A4	02535001	80	16x110	97	85	✓ / ✓	100	16x90	77	65	200	M16x121	10	3,20
BZ 16-100/220 A4	02540001	100	16x110	97	85	- / -	-	-	-	-	220	M16x80	10	3,59
BZ 16-160/280 A4	02553001	160	16x110	97	85	- / -	-	-	-	-	280	M16x80	10	4,50
BZ 20-30/165 A4	02615501	30	20x125	114	100	✓ / ✓	-	-	-	-	165	M20x50	10	4,51
BZ 20-60/195 A4	02625501	60	20x125	114	100	✓ / ✓	-	-	-	-	195	M20x70	10	5,14
BZ 20-100/235 A4	02630501	100	20x125	114	100	- / -	-	-	-	-	235	M20x80	5	3,09
BZ 20-130/265 A4	02635501	130	20x125	114	100	- / -	-	-	-	-	265	M20x80	5	3,48
BZ 20-150/285 A4	02640501	150	20x125	114	100	- / -	-	-	-	-	285	M20x80	5	3,73
BZ 24-30/200 A4	02717501	30	24x155	140	125	- / -	-	-	-	-	200	M24x58	10	7,25
BZ 24-60/230 A4	02727501	60	24x155	140	125	- / -	-	-	-	-	230	M24x88	5	4,12
BZ 24-75/245 A4	02737501	75	24x155	140	125	- / -	-	-	-	-	245	M24x103	5	4,34

Other lengths on demand.

Wedge Anchor BZ-U plus A4



- Stainless steel A4
- With large washer DIN EN ISO 7093-1 (DIN 9021)
- Approved for cracked and non-cracked concrete

Description	Ref. No.	Standard anchorage depth					Reduced anchorage depth				Anchor length l mm	Thread mm	Washer ¹⁾ mm	Pkg. content pcs.	Weight per pkg. kg
		max. Fixture thickness t _{fix} mm	Drill hole Ø x depth mm	Setting depth h _{nom} mm	Anchorage depth h _{ef} mm	Seismic C1 / C2	max. Fixture thickness t _{fix,red} mm	Drill hole Ø x depth mm	Setting depth h _{nom,red} mm	Anchorage depth h _{ef,red} mm					
BZ-U 8-10-21/75 A4	02115301	10	8x60	52	46	✓ / ✓	21	8x49	41	35	75	M8x32	24x2	100	3,46
BZ-U 8-15-26/80 A4	02125301	15	8x60	52	46	✓ / ✓	26	8x49	41	35	80	M8x37	24x2	100	3,52
BZ-U 8-30-41/95 A4	02140301	30	8x60	52	46	✓ / ✓	41	8x49	41	35	95	M8x52	24x2	100	4,01
BZ-U 8-50-61/115 A4	02150301	50	8x60	52	46	✓ / ✓	61	8x49	41	35	115	M8x72	24x2	100	4,63
BZ-U 10-10-30/90 A4	02215301	10	10x75	68	60	✓ / ✓	30	10x55	48	40	90	M10x42	30x2,5	50	3,30
BZ-U 10-15-35/95 A4	02220301	15	10x75	68	60	✓ / ✓	35	10x55	48	40	95	M10x47	30x2,5	50	3,45
BZ-U 10-30-50/110 A4	02230301	30	10x75	68	60	✓ / ✓	50	10x55	48	40	110	M10x62	30x2,5	50	3,95
BZ-U 10-50-70/130 A4	02235301	50	10x75	68	60	✓ / ✓	70	10x55	48	40	130	M10x82	30x2,5	50	4,31
BZ-U 12-15-35/110 A4	02315301	15	12x90	80	70	✓ / ✓	35	12x70	60	50	110	M12x51	37x3	25	2,86
BZ-U 12-20-40/115 A4	02320301	20	12x90	80	70	✓ / ✓	40	12x70	60	50	115	M12x56	37x3	25	3,06
BZ-U 12-30-50/125 A4	02325301	30	12x90	80	70	✓ / ✓	50	12x70	60	50	125	M12x66	37x3	25	3,26
BZ-U 12-50-70/145 A4	02330301	50	12x90	80	70	✓ / ✓	70	12x70	60	50	145	M12x86	37x3	25	3,68
BZ-U 16-25-45/145 A4	02525301	25	16x110	97	85	✓ / ✓	45	16x90	77	65	145	M16x66	50x3	20	5,15

¹⁾Outer diameter x thickness
Other lengths on demand.



Extract from Permissible Service Conditions of European Technical Assessment ETA-99/0010

Approved loads for single anchor without influence of spacing and edge distance.

Total safety factor as per ETAG 001 included (γ_M and γ_P). Load capacities under fire exposure see page 166.

Loads and performance data			Wedge Anchor BZ plus A4		M8	M10	M12	M16	M20	M24		
Standard anchorage depth	h_{ef}	[mm]	46	-	60	-	70	-	85	-	100	125
Reduced anchorage depth	$h_{ef,red}$	[mm]	-	35	-	40	-	50	-	65	-	-
cracked concrete												
Mean ultimate loads, tension	C25/30	[kN]	10,8	8,8	16,7	12,4	27,5	17,6	40,0	30,1	54,3	68,8
Mean ultimate loads, shear	C25/30	[kN]	19,0	16,3	28,5	25,5	35,8	40,8	70,3	60,5	108,4	149,5
Approved loads, tension	C20/25 appr. N	[kN]	2,4	2,4	4,3	3,6	7,6	6,1	11,9	9,0	17,1	19,0
	C25/30 appr. N	[kN]	2,6	2,6	4,7	3,9	8,3	6,6	13,0	9,8	18,8	20,9
	C30/37 appr. N	[kN]	2,9	2,9	5,2	4,3	9,3	7,4	14,5	10,9	20,9	23,2
	C40/50 appr. N	[kN]	3,4	3,4	6,1	5,1	10,8	8,6	16,8	12,7	24,2	26,9
	C50/60 appr. N	[kN]	3,7	3,7	6,6	5,5	11,8	9,4	18,4	13,9	26,6	29,5
non-cracked concrete												
Approved loads, tension	C20/25 appr. N	[kN]	5,7	3,6	7,6	4,3	11,9	8,5	16,7	12,6	24,0	33,6
	C25/30 appr. N	[kN]	6,3	3,9	8,3	4,7	13,0	9,3	18,3	13,8	26,3	36,8
	C30/37 appr. N	[kN]	7,0	4,3	9,3	5,2	14,5	10,3	20,3	15,3	29,3	40,9
	C40/50 appr. N	[kN]	7,6	5,1	10,8	6,1	16,8	12,0	23,6	17,8	34,0	47,5
	C50/60 appr. N	[kN]	7,6	5,5	11,8	6,6	18,4	13,2	25,8	19,5	37,3	52,1
cracked / non-cracked concrete												
Approved loads, shear	C20/25 appr. V	[kN]	7,4	7,4	11,4	10,4/11,4	17,1	14,5/17,1	31,4	21,6/30,2	43,9	67,1/70,6
	\geq C25/30 appr. V	[kN]	7,4	7,4	11,4	11,4	17,1	15,9/17,1	31,4	23,6/31,4	43,9	70,6
Approved bending moments	appr. M	[Nm]	14,9	14,9	29,7	29,7	52,6	52,6	114,3	114,3	231,6	448,8
Spacing and edge distance												
Effective anchorage depth	h_{ef}	[mm]	46	35	60	40	70	50	85	65	100	125
Characteristic spacing	$s_{cr, N}$	[mm]	138	105	180	120	210	150	255	195	300	375
Characteristic edge distance	$c_{cr, N}$	[mm]	69	52,5	90	60	105	75	127,5	97,5	150	187,5
Minimum spacing and edge distance for standard thickness of concrete member												
cracked concrete												
Standard thickness of concrete slab	$h_{min,1}$	[mm]	100	-	120	-	140	-	160	-	200	250
Minimum spacing / for edge distance c	s_{min} / c	[mm]	40/70	-	50/75	-	60/100	-	60/100	-	95/150	125/125
Minimum edge distance / for spacing s	c_{min} / s	[mm]	40/80	-	55/90	-	60/140	-	60/180	-	95/200	125/125
non-cracked concrete												
Minimum spacing / for edge distance c	s_{min} / c	[mm]	40/80	-	50/75	-	60/120	-	65/120	-	90/180	125/125
Minimum edge distance / for spacing s	c_{min} / s	[mm]	50/100	-	60/120	-	75/150	-	80/150	-	130/240	125/125
Minimum spacing and edge distance for minimum thickness of concrete member												
cracked concrete												
Minimum thickness of concrete slab	h_{min1}/h_{min2}	[mm]	80	80	100	80	120	100	140	140	-	-
Minimum spacing / for edge distance c	s_{min} / c	[mm]	40/70	50/60	45/90	50/100	60/100	50/160	70/160	65/170	-	-
Minimum edge distance / for spacing s	c_{min} / s	[mm]	40/80	40/185	50/115	65/180	60/140	65/250	80/180	100/250	-	-
non-cracked concrete												
Minimum spacing / for edge distance c	s_{min} / c	[mm]	40/80	50/60	60/140	50/100	60/120	50/160	80/180	65/170	-	-
Minimum edge distance / for spacing s	c_{min} / s	[mm]	50/100	40/185	90/140	65/180	75/150	100/185	90/200	170/65	-	-
Installation parameters												
Drill hole diameter	d_o	[mm]	8	8	10	10	12	12	16	16	20	24
Diameter of clearance hole in the fixture	d_f	[mm]	9	9	12	12	14	14	18	18	22	26
Depth of drill hole	h_1	[mm]	60	49	75	55	90	70	110	90	125	155
Installation torque	T_{inst}	[Nm]	20	20	35	35	50	50	110	110	200	290
Width across nut	SW	[mm]	13	13	17	17	19	19	24	24	30	36

For anchor designing, an easy to operate CD-ROM is available on request or can be downloaded at www.mkt.de.

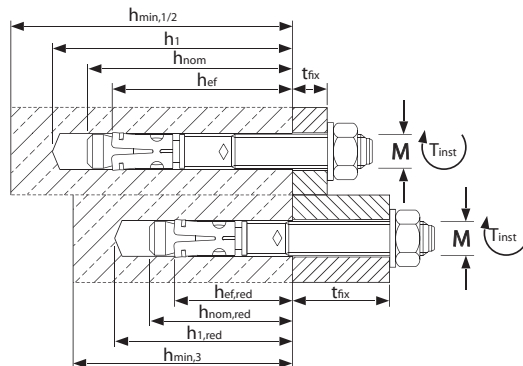
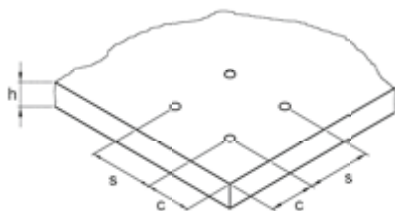

Installation

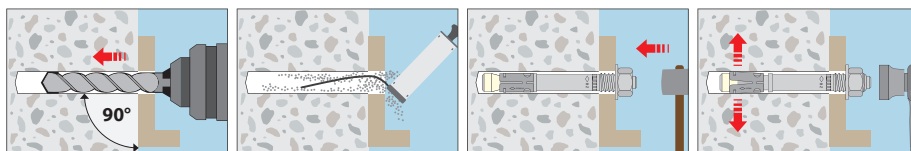

Wedge Anchor BZ plus HCR

High corrosion resistant steel 1.4529 (HCR)



Wedge Anchor
BZ plus s HCR



Wedge Anchor
BZ plus HCR



Wedge Anchor
BZ-U plus HCR



Approvals and Certificates



Range of Loading: 2,4 kN - 70,6 kN

Range of concrete quality: C20/25 - C50/60

Description

There has been further improvement to the performance and application range of the wedge anchor BZ plus HCR. The new European Technical Assessment replaces the previous European technical approval. Now its suitability has been verified for seismic loading, performance categories C1 and C2. Variants include a second effective anchorage depth, longer thread, and new sizes with a shorter overall length and only the one effective anchorage depth.

Advantages

- Approved under the building regulations with a new European Technical Assessment (Option 1)
- Approved for use in cracked and non-cracked concrete
- Approved for use under seismic loading, performance categories C1 and C2 (on demand for M8 to M20, maximum anchor length 210 mm)
- Suitable for use in compression resistant natural stone (without approval)
- Two effective anchorage depths for greater flexibility (on demand for M8 to M16, maximum anchor length 210 mm)
- Anchoring with the smaller effective anchorage depth reduces drilling and installation time.
- Anchoring with the standard effective anchorage depth is suitable for the highest load limits
- Particularly cost effective: the short "s" versions with only one effective anchorage depth in the sizes M8 to M16
- Suitable for surface, through, and stand-off fastening
- Approved for use under fire exposure. Fire resistance ratings R30-R120
- Suitable for sprinkler system installations complying with VdS requirements
- FM approval for the installation of sprinkler systems (M10 to M16)
- Shock approval by the Swiss Federal Office for Civil Protection

Applications

Medium to heavy duty anchorings which are exposed to highly corrosive atmospheres with high concentration of sulphur dioxides, chlorides, humidity: attaching brackets, ventilation systems, suspended ceilings, cable trays, in road tunnels, indoor swimming pools, etc.

Example of Installation

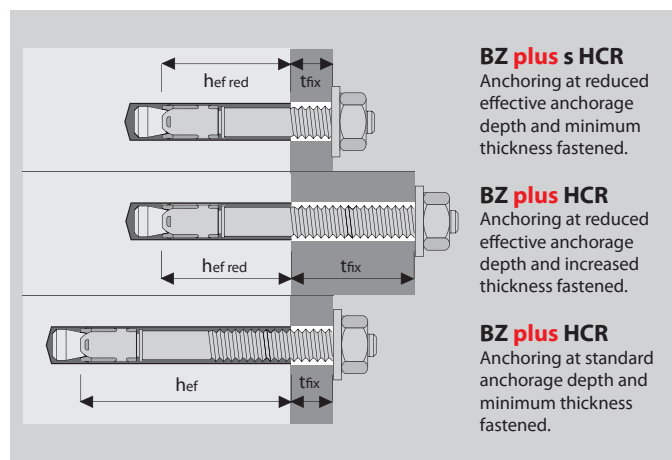

¹⁾Only standard anchorage depth

Wedge Anchor BZ plus HCR



→ High corrosion resistant steel 1.4529 (HCR)

→ Approved for cracked and non-cracked concrete

Description	Ref. No.	Standard anchorage depth					Reduced anchorage depth				Anchor length l mm	Thread mm	Pkg. content pcs.	Weight per pkg. kg
		max. Fixture thickness t _{fix} mm	Drill hole Ø x depth mm	Setting depth h _{nom} mm	Anchorage depth h _{ef} mm	Seismic C1 / C2	max. Fixture thickness t _{fix,red} mm	Drill hole Ø x depth mm	Setting depth h _{nom,red} mm	Anchorage depth h _{ef,red} mm				
BZ 8-11/65 s HCR ¹⁾	07110001	-	-	-	-	- / -	11	8x49	41	35	65	M8x22	100	2,74
BZ 8-10-21/75 HCR	07115001	10	8x60	52	46	✓ / ✓	21	8x49	41	35	75	M8x32	100	3,08
BZ 8-15-26/80 HCR	07125001	15	8x60	52	46	✓ / ✓	26	8x49	41	35	80	M8x37	100	3,22
BZ 8-30-41/95 HCR	07140001	30	8x60	52	46	✓ / ✓	41	8x49	41	35	95	M8x52	100	3,72
BZ 8-50-61/115 HCR	07150001	50	8x60	52	46	✓ / ✓	61	8x49	41	35	115	M8x72	100	4,35
BZ 10-10/70 s HCR ¹⁾	07205001	-	-	-	-	- / -	10	10x55	48	40	70	M10x22	50	2,44
BZ 10-10-30/90 HCR	07215001	10	10x75	68	60	✓ / ✓	30	10x55	48	40	90	M10x42	50	3,02
BZ 10-15-35/95 HCR	07220001	15	10x75	68	60	✓ / ✓	35	10x55	48	40	95	M10x47	50	3,14
BZ 10-30-50/110 HCR	07230001	30	10x75	68	60	✓ / ✓	50	10x55	48	40	110	M10x62	50	3,90
BZ 10-50-70/130 HCR	07235001	50	10x75	68	60	✓ / ✓	70	10x55	48	40	130	M10x82	50	4,31
BZ 12-10/85 s HCR ¹⁾	07305001	-	-	-	-	- / -	10	12x70	60	50	85	M12x26	25	2,51
BZ 12-15-35/110 HCR	07315001	15	12x90	80	70	✓ / ✓	35	12x70	60	50	110	M12x51	25	2,55
BZ 12-20-40/115 HCR	07320001	20	12x90	80	70	✓ / ✓	40	12x70	60	50	115	M12x56	25	2,66
BZ 12-30-50/125 HCR	07325001	30	12x90	80	70	✓ / ✓	50	12x70	60	50	125	M12x66	25	2,88
BZ 12-50-70/145 HCR	07330001	50	12x90	80	70	✓ / ✓	70	12x70	60	50	145	M12x86	25	3,23
BZ 16-25-45/145 HCR	07525001	25	16x110	97	85	✓ / ✓	45	16x90	77	65	145	M16x66	20	4,90
BZ 16-50-70/170 HCR	07530001	50	16x110	97	85	✓ / ✓	70	16x90	77	65	170	M16x91	20	5,80
BZ 16-100/220 HCR	07540001	100	16x110	97	85	- / -	-	-	-	-	220	M16x80	10	3,70
BZ 20-30/165 HCR	07615001	30	20x125	114	100	✓ / ✓	-	-	-	-	165	M20x50	10	4,95

¹⁾Delivery time on request.

Other lengths on demand. BZ plus M24 HCR on demand.

Wedge Anchor BZ-U plus HCR



→ High corrosion resistant steel 1.4529 (HCR)

→ With large washer DIN EN ISO 7093-1 (DIN 9021)

→ Approved for cracked and non-cracked concrete

Description	Ref. No.	Standard anchorage depth					Reduced anchorage depth				Anchor length l mm	Thread mm	Washer ²⁾ mm	Pkg. content pcs.	Weight per pkg. kg
		max. Fixture thickness t _{fix} mm	Drill hole Ø x depth mm	Setting depth h _{nom} mm	Anchorage depth h _{ef} mm	Seismic C1 / C2	max. Fixture thickness t _{fix,red} mm	Drill hole Ø x depth mm	Setting depth h _{nom,red} mm	Anchorage depth h _{ef,red} mm					
BZ-U 8-10-21/75 HCR	07115301	10	8x60	52	46	✓ / ✓	21	8x49	41	35	75	M8x32	24x2	100	3,46
BZ-U 10-10-30/90 HCR	07215301	10	10x75	68	60	✓ / ✓	30	10x55	48	40	90	M10x42	30x2,5	50	3,30
BZ-U 12-30-50/125 HCR	07325301	30	12x90	80	70	✓ / ✓	50	12x70	60	50	125	M12x66	37x3	25	3,26

²⁾Outer diameter x thickness

Other lengths on demand.



Extract from Permissible Service Conditions of European Technical Assessment ETA-99/0010

Approved loads for single anchor without influence of spacing and edge distance.

Total safety factor as per ETAG 001 included (γ_M and γ_P). Load capacities under fire exposure see page 166.

Loads and performance data	Wedge Anchor BZ plus HCR		M8	M10	M12	M16	M20	M24
Standard anchorage depth	h_{ef}	[mm]	46	60	70	85	100	125
Reduced anchorage depth	$h_{ef, red}$	[mm]	35	40	50	65	-	-
cracked concrete								
Mean ultimate loads, tension	C25/30	[kN]	10,8	16,7	27,5	40,0	54,3	68,8
Mean ultimate loads, shear	C25/30	[kN]	19,0	28,5	35,8	40,8	108,4	149,5
Approved loads, tension	C20/25 appr. N	[kN]	2,4	4,3	7,6	11,9	17,1	19,0
	C25/30 appr. N	[kN]	2,6	4,7	8,3	13,0	20,9	20,9
	C30/37 appr. N	[kN]	2,9	5,2	9,3	14,5	23,2	23,2
	C40/50 appr. N	[kN]	3,4	6,1	10,8	16,8	26,9	26,9
	C50/60 appr. N	[kN]	3,7	6,6	11,8	18,4	29,5	29,5
non-cracked concrete								
Approved loads, tension	C20/25 appr. N	[kN]	5,7	7,6	11,9	16,7	24,0	33,6
	C25/30 appr. N	[kN]	6,3	8,3	13,0	18,3	26,3	36,8
	C30/37 appr. N	[kN]	7,0	9,3	14,5	20,3	29,3	40,9
	C40/50 appr. N	[kN]	7,6	10,8	16,8	23,6	34,0	47,5
	C50/60 appr. N	[kN]	7,6	11,8	18,4	25,8	37,3	52,1
cracked / non-cracked concrete								
Approved loads, shear	C20/25 appr. V	[kN]	7,4	11,4	17,1	31,4	43,9	67,1/70,6
	\geq C25/30 appr. V	[kN]	7,4	11,4	17,1	31,4	43,9	70,6
Approved bending moments	appr. M	[Nm]	14,9	29,7	52,6	114,3	231,6	448,8

Spacing and edge distance

	h_{ef}	[mm]	46	35	60	40	70	50	85	65	100	125
Effective anchorage depth	h_{ef}	[mm]	46	35	60	40	70	50	85	65	100	125
Characteristic spacing	$s_{cr, N}$	[mm]	138	105	180	120	210	150	255	195	300	375
Characteristic edge distance	$c_{cr, N}$	[mm]	69	52,5	90	60	105	75	127,5	97,5	150	187,5

Minimum spacing and edge distance for standard thickness of concrete member

		cracked concrete										
Standard thickness of concrete slab	$h_{min,1}$	[mm]	100	-	120	-	140	-	160	-	200	250
Minimum spacing / for edge distance c	s_{min} / c	[mm]	40/70	-	50/75	-	60/100	-	60/100	-	95/150	125/125
Minimum edge distance / for spacing s	c_{min} / s	[mm]	40/80	-	55/90	-	60/140	-	60/180	-	95/200	125/125
		non-cracked concrete										
Minimum spacing / for edge distance c	s_{min} / c	[mm]	40/80	-	50/75	-	60/120	-	65/120	-	90/180	125/125
Minimum edge distance / for spacing s	c_{min} / s	[mm]	50/100	-	60/120	-	75/150	-	80/150	-	130/240	125/125

Minimum spacing and edge distance for minimum thickness of concrete member

		cracked concrete										
Minimum thickness of concrete slab	h_{min1}/h_{min2}	[mm]	80	80	100	80	120	100	140	140	-	-
Minimum spacing / for edge distance c	s_{min} / c	[mm]	40/70	50/60	45/90	50/100	60/100	50/160	70/160	65/170	-	-
Minimum edge distance / for spacing s	c_{min} / s	[mm]	40/80	40/185	50/115	65/180	60/140	65/250	80/180	100/250	-	-
		non-cracked concrete										
Minimum spacing / for edge distance c	s_{min} / c	[mm]	40/80	50/60	60/140	50/100	60/120	50/160	80/180	65/170	-	-
Minimum edge distance / for spacing s	c_{min} / s	[mm]	50/100	40/185	90/140	65/180	75/150	100/185	90/200	170/65	-	-

Installation parameters

		[mm]	8	8	10	10	12	12	16	16	20	24
Drill hole diameter	d_o	[mm]	8	8	10	10	12	12	16	16	20	24
Diameter of clearance hole in the fixture	d_f	[mm]	9	9	12	12	14	14	18	18	22	26
Depth of drill hole	h_1	[mm]	60	49	75	55	90	70	110	90	125	155
Installation torque	T_{inst}	[Nm]	20	20	35	35	50	50	110	110	200	290
Width across nut	SW	[mm]	13	13	17	17	19	19	24	24	30	36

For anchor designing, an easy to operate CD-ROM is available on request or can be downloaded at www.mkt.de.

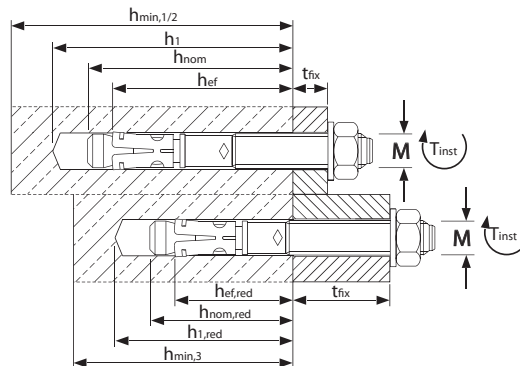
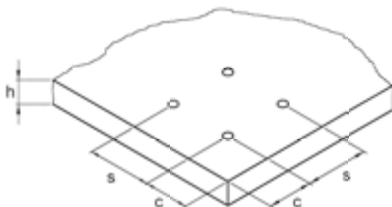

Installation

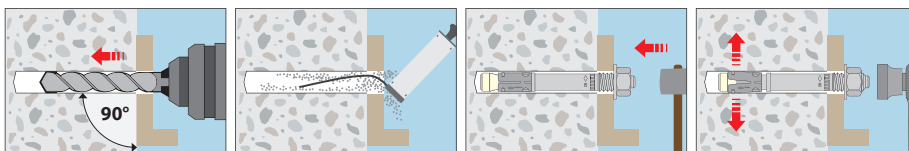

Wedge Anchor BZ-IG

Steel, zinc plated

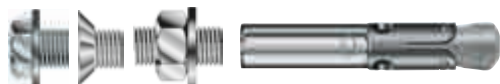

Range of Loading: 2,0 kN - 18,5 kN

Range of concrete quality: C20/25 - C50/60

Description

The fastening system BZ-IG is the first approved (ETA-99/0010) wedge anchor for cracked concrete with internal thread. It combines the benefits of a mechanical anchor with an easy installation and the flexibility of an internal thread. For the first time it is possible to fasten balcony and stair railings or stadium seats using a countersunk head screw at favourable costs. Since this anchor system is also approved for use with hexagon head screws and standard threaded rods a wide range of applications is possible. Compared to a drop in anchor the fastening system BZ-IG can carry significant higher loads, even in cracked concrete. The versatility of the MKT Fastening System BZ-IG breaks new ground in design and application.

Applications:

Medium to heavy duty fastenings in cracked and non-cracked concrete: Railings, suspended ceilings, ladders, doors, sprinkler systems, pipe hangers and all kinds of temporary fastenings.

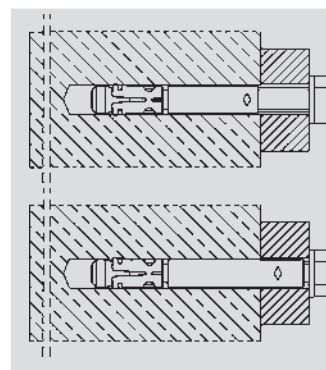

Pre-installation:

For pre-installation the anchor gets installed below the concrete surface. When the coated screw gets removed the anchor leaves flush with the concrete surface. So it's excellent for temporary fastenings.

Through fastening:

If through-fastening is used the fixture can be used as drilling template. Afterwards the anchor can be installed through the clearance hole in the fixture. So it combines easy installation with the aesthetics of a screw head.

Pre-Installation

Wedge Anchor BZ-IG¹⁾



- Steel, zinc plated; Pre-Installation
- Approved for cracked and non-cracked concrete

Description	Ref. No.	Drill hole	Anchor length	Thread	Pkg. content.	Weight per pkg.
		Ø x depth		Ø x length		
		mm	mm	mm	pcs.	kg
BZ-IG M 6-0	03600101	8 x 60	50	M6x20	100	1,42
BZ-IG M 8-0	03610101	10 x 75	62	M8x22	50	1,31
BZ-IG M 10-0	03620101	12 x 90	70	M10x23	25	1,08
BZ-IG M 12-0	03630101	16 x 105	86	M12x27	20	2,03

Coated Screw DIN 933 with Washer DIN EN ISO 7089 (DIN 125)¹⁾



Description	Ref. No.	Fixture thickn. t _{fix} mm	Pkg. content pcs.	Weight per pkg. kg
S-IG 6x25	54010101	4-12	100	0,80
S-IG 8x25	54110101	2-8	50	0,79
S-IG 10x40	54210101	15-19	25	0,90
S-IG 12x45	54310101	16-21	20	1,13

¹⁾Screws (Strength class 8.8) or hex nuts and washers to be ordered separately. Other screw lengths on demand. Threaded stud must have at least the strength of 8.8. Threaded studs with the certificate see page 108.

Coated Hex Nut DIN 933 with Washer DIN EN ISO 7089 (DIN 125)¹⁾



Description	Ref. No.	Pkg. content pcs	Weight per pkg. kg
MU-IG 6	56005101	100	0,32
MU-IG 8	56105101	50	0,35
MU-IG 10	56205101	25	0,36
MU-IG 12	56305101	20	0,45

Coated Countersunk Screw DIN 7991 with Countersunk Washer¹

Description	Ref. No.	Fixture thickn. t _{fix} mm	Pkg. content pcs.	Wght. per pkg. kg
SK-IG 6x25 ²⁾	55013101	6-14	100	0,78
SK-IG 8x30 ²⁾	55112101	9-15	50	0,59
SK-IG 10x30	55211101	8-11	25	0,48
SK-IG 12x35	55311101	9-14	20	0,64

¹⁾Screws (Strength class 8.8) or hex nuts and washers to be ordered separately.

²⁾Screw similar to DIN 7991 with Torx®-drive. Size see page 21.

Other screw lengths according to DIN 933 on demand.

Threaded stud must have at least the strength of 8.8. Threaded studs with the certificate see page 108.

Setting Tool BZ-IG for Pre-Installation

Description	Ref. No.	Weight per pcs. kg
BZ-IGS M 6V	43005150	0,43
BZ-IGS M 8V	43100150	0,44
BZ-IGS M 10V	43200150	0,46
BZ-IGS M 12V	43300150	0,56

Through Fastening
Wedge Anchor BZ-IG¹⁾

→ Steel, zinc plated; Through Fastening

→ Approved for cracked and non-cracked concrete

Description	Ref. No.	Drill hole Ø x depth mm	Drill hole depth through fixture mm	Fixture thickness t _{fix} mm		Anchor length l mm	Thread Ø x length mm	Pkg. content pcs	Weight per pkg. kg
				Typ S-IG	Typ SK-IG				
BZ-IG M 6-10	03602101	8 x 60	74	10	14	60	M6 x 20	100	1,80
BZ-IG M 6-20	03604101	8 x 60	84	20	24	70	M6 x 20	100	2,20
BZ-IG M 6-30	03606101	8 x 60	94	30	34	80	M6 x 20	100	2,60
BZ-IG M 8-10	03611101	10 x 75	90	10	15	72	M8 x 22	50	1,65
BZ-IG M 8-20	03612101	10 x 75	100	20	25	82	M8 x 22	50	1,95
BZ-IG M 8-30	03613101	10 x 75	110	30	35	92	M8 x 22	50	2,25
BZ-IG M 10-10	03621101	12 x 90	106	10	16	80	M10 x 23	25	1,32
BZ-IG M 10-20	03622101	12 x 90	116	20	26	90	M10 x 23	25	1,48
BZ-IG M 10-30	03623101	12 x 90	126	30	36	100	M10 x 23	25	1,76
BZ-IG M 12-10	03631101	16 x 105	122	10	17	96	M12 x 27	20	2,34
BZ-IG M 12-20	03632101	16 x 105	132	20	27	106	M12 x 27	20	2,66
BZ-IG M 12-30	03633101	16 x 105	142	30	37	116	M12 x 27	20	2,97

Coated Screw DIN 933 with Washer DIN EN ISO 7089 (DIN 125)¹⁾

Description	Ref. No.	Pkg. content pcs	Weight per pcs. kg
S-IG 6x16	54020101	100	0,64
S-IG 8x18	54120101	50	0,68
S-IG 10x20	54220101	25	0,64
S-IG 12x25	54320101	20	0,67

¹⁾Screws (Strength class 8.8) to be ordered separately.

Coated Countersunk Screw DIN 7991 with Countersunk Washer¹⁾

Description	Ref. No.	Pkg. content pcs	Weight per pcs. kg
SK-IG 6x16	55010101	100	0,64
SK-IG 8x20	55110101	50	0,60
SK-IG 10x25	55210101	25	0,62
SK-IG 12x30	55310101	20	0,80

²⁾Screw similar to DIN 7991 with Torx®-drive. Size see page 21.

Setting Tool BZ-IG for Through Fastening

Description	Ref. No.	Weight per pcs. kg
BZ-IGS M 6D	43005155	0,32
BZ-IGS M 8D	43100155	0,33
BZ-IGS M 10D	43200155	0,33
BZ-IGS M 12D	43300155	0,35



Extract from Permissible Service Conditions of European Technical Assessment ETA-99/0010

Approved loads for single anchor without influence of spacing and edge distance.

Total safety factor as per ETAG 001 included (γ_M and γ_P). Load capacities under fire exposure see page 166.

Loads and performance data	Wedge Anchor BZ-IG	M 6	M 8	M 10	M 12	
cracked concrete						
Mean ultimate loads, tension	C25/30 Num	[kN]	14,1	19,8	28,3	45,9
Mean ultimate loads, shear	C25/30 Vum	[kN]	8,7	11,4	14,8	33,9
Approved loads, tension	C20/25 appr. N	[kN]	2,0	3,6	4,8	7,9
	C25/30 appr. N	[kN]	2,2	3,9	5,2	8,7
	C30/37 appr. N	[kN]	2,4	4,4	5,8	9,7
	C40/50 appr. N	[kN]	2,8	5,0	6,7	11,2
	C50/60 appr. N	[kN]	3,1	5,5	7,4	12,3
non-cracked concrete						
Approved loads, tension	C20/25 appr. N	[kN]	4,8	6,3	7,9	11,9
	C25/30 appr. N	[kN]	5,2	7,0	8,7	13,1
	C30/37 appr. N	[kN]	5,8	7,7	9,7	14,5
	C40/50 appr. N	[kN]	6,7	9,0	11,2	16,8
	C50/60 appr. N	[kN]	7,4	9,8	12,3	18,5
cracked and non-cracked concrete						
Approved loads, shear (Pre-Installation)	\geq C20/25 appr. V	[kN]	3,3	3,9	5,9	14,7
Approved loads, shear (Through Fastening)	\geq C20/25 appr. V	[kN]	2,9	4,3	6,2	13,9
Approved bending moments (Pre-Installation)	appr. M	[Nm]	7,0	17,1	34,2	59,8
Approved bending moments (Through Fastening)	appr. M	[Nm]	20,6	30,4	43,4	118,3
Spacing and edge distance						
Effective anchorage depth	h_{ef}	[mm]	45	58	65	80
Characteristic spacing	$s_{cr,N}$	[mm]	135	174	195	240
Characteristic edge distance	$c_{cr,N}$	[mm]	67,5	87	97,5	120
cracked concrete						
Minimum spacing / for edge distance c	s_{min} / C	[mm]	50 / 60	60 / 80	70 / 100	80 / 120
Minimum edge distance / for spacing s	c_{min} / S	[mm]	50 / 75	60 / 100	70 / 100	80 / 120
non-cracked concrete						
Minimum spacing / for edge distance c	s_{min} / C	[mm]	50 / 80	60 / 100	65 / 120	80 / 160
Minimum edge distance / for spacing s	c_{min} / S	[mm]	50 / 115	60 / 155	70 / 170	100 / 210
Minimum thickness of concrete slab	h_{min}	[mm]	100	120	130	160
Installation parameters						
Drill hole diameter	d_o	[mm]	8	10	12	16
Diameter of clearance hole in the fixture - Pre-Installation	d_f	[mm]	7	9	12	14
Diameter of clearance hole in the fixture - Through Fastening	d_f	[mm]	9	12	14	18
Depth of drill hole	h_1	[mm]	60	75	90	105
Installation torque	Screw DIN 933 T_{inst}	[Nm]	10	30	30	55
	Countersunk screw T_{inst}	[Nm]	10	25	40	50
	Threaded rod T_{inst}	[Nm]	8	25	30	45
Width across nut	Screw DIN 933 SW	[mm]	10	13	17	19
Internal hexagon size	Countersunk screw SW	[mm]	-	-	6	8
Torx® size	Countersunk screw		T30	T45	-	-
Min. thickness of fixture	Screw DIN 933 or Threaded rod $t_{fix} \geq$	[mm]	1 / 5 ¹⁾	1 / 7 ¹⁾	1 / 8 ¹⁾	1 / 9 ¹⁾
Min. thickness of fixture	Countersunk screw $t_{fix} \geq$	[mm]	5 / 9 ¹⁾	7 / 12 ¹⁾	8 / 14 ¹⁾	9 / 16 ¹⁾

¹⁾Pre-Installation / Through Installation. For anchor designing, an easy to operate CD-ROM is available on request or can be downloaded at www.mkt.de.

Pre-installation:

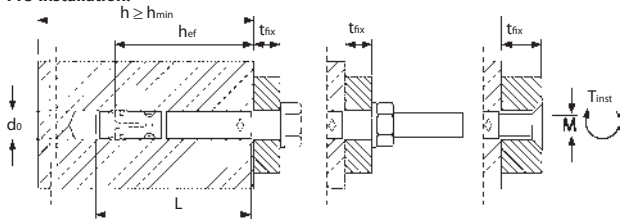

Through fastening:

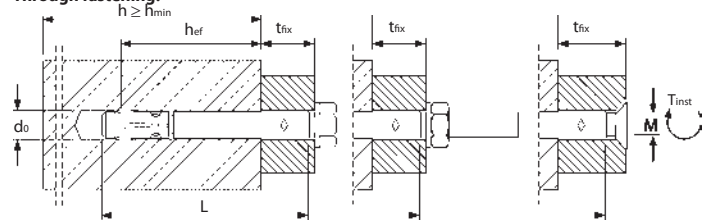

Installation (Pre-installation)

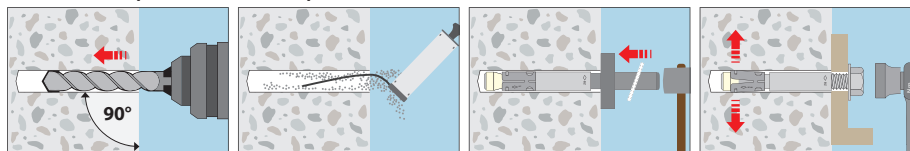

Installation (Through fastening)

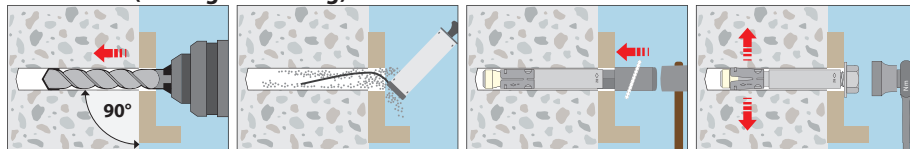

Dimension countersunk washer [mm]

	d1	d2	h
SK M 6	16,5	9,5	3,9
SK M 8	20,5	11,5	5,0
SK M 10	24,5	14,5	5,7
SK M 12	29,5	17,5	6,7

Countersunk head

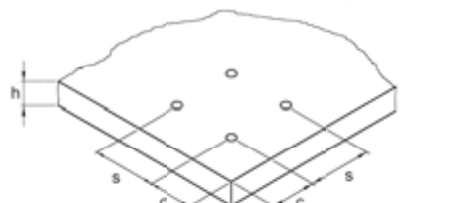

Mechanical Heavy Duty Anchors

Wedge Anchor BZ-IG A4

Stainless Steel A4/316

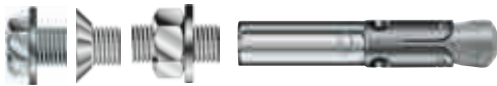

Range of Loading: 2,0 kN - 18,5 kN
Range of concrete quality: C20/25 - C50/60

Description

The fastening system BZ-IG A4 is the first approved (ETA-99/0010) wedge anchor for cracked concrete with internal thread. It combines the benefits of a mechanical anchor with an easy installation and the flexibility of an internal thread. For the first time it is possible to fasten balcony and stair railings or stadium seats using a countersunk head screw at favourable costs. Since this anchor system is also approved for use with hexagon head screws and standard threaded rods a wide range of applications is possible. Compared to a drop in anchor the fastening system BZ-IG A4 can carry significant higher loads, even in cracked concrete. The versatility of the MKT Fastening System BZ-IG breaks new ground in design and application.

Applications

Medium to heavy duty fastenings in cracked and non-cracked concrete: Railings, chairs in sports arenas, facade substructures, suspended ceilings, ladders, doors, sprinkler systems, pipe hangers and all kinds of temporary fastenings.

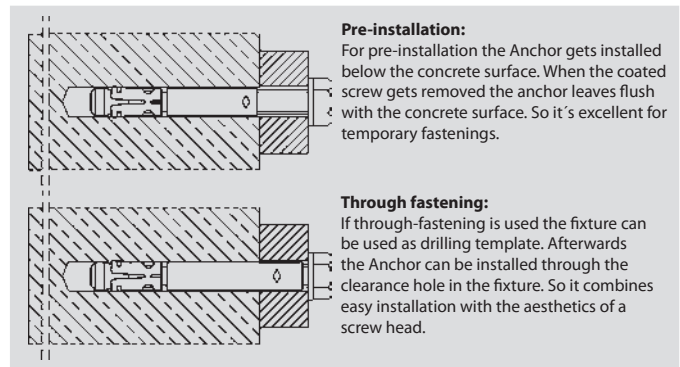

Pre-Installation

Wedge Anchor BZ-IG A4¹⁾



→ Stainless steel A4/316; Pre-Installation

→ Approved for cracked and non-cracked concrete

Description	Ref. No.	Drill hole	Anchor length	Thread	Pkg. content.	Weight per pkg.
		Ø x depth		Ø x length		
		mm	mm	mm	pcs.	kg
BZ-IG M 6-0 A4	03600501	8 x 60	50	M6x20	100	1,42
BZ-IG M 8-0 A4	03610501	10 x 75	62	M8x22	50	1,31
BZ-IG M 10-0 A4	03620501	12 x 90	70	M10x23	25	1,08
BZ-IG M 12-0 A4	03630501	16 x 105	86	M12x27	20	2,03

Coated Screw DIN 933 with Washer DIN EN ISO 7089 (DIN 125)¹⁾



Description	Ref. No.	Fixture thickn. t _{fix} mm	Pkg. content pcs.	Weight per pkg. kg
S-IG 6x25 A4	54010501	4-12	100	0,80
S-IG 8x25 A4	54110501	2-8	50	0,79
S-IG 10x40 A4	54210501	15-19	25	0,90
S-IG 12x45 A4	54310501	16-21	20	1,13

Coated Hex Nut DIN 933 with Washer DIN EN ISO 7089 (DIN 125)¹⁾



Description	Ref. No.	Pkg. content pcs	Weight per pkg. kg
MU-IG 6 A4	56005501	100	0,32
MU-IG 8 A4	56105501	50	0,35
MU-IG 10 A4	56205501	25	0,36
MU-IG 12 A4	56305501	20	0,45

¹⁾Screws or hex nuts and washers to be ordered separately.

Coated Countersunk Screw DIN 7991 with Countersunk Washer¹⁾



Description	Ref. No.	Fixture thickn. t _{fix} mm	Pkg. content pcs.	Wght. per pkg. kg
SK-IG 6x25 A4 ²⁾	55013501	6-14	100	0,53
SK-IG 8x30 A4 ²⁾	55112501	9-15	50	0,59
SK-IG 10x30 A4	55211501	8-11	25	0,48
SK-IG 12x35 A4	55311501	9-14	20	0,64

¹⁾Screws or hex nuts and washers to be ordered separately.

²⁾Screw similar to DIN 7991 with Torx®-drive. Size see page 24.

Anchor system in high corrosion resistant steel grade 1.4529 on demand. Other screw lengths according to DIN 933 on demand.

Setting Tool BZ-IG for Pre-Installation



Description	Ref. No.	Weight per pcs. kg
BZ-IGS M 6V	43005150	0,43
BZ-IGS M 8V	43100150	0,44
BZ-IGS M 10V	43200150	0,46
BZ-IGS M 12V	43300150	0,56

Through Fastening

Wedge Anchor BZ-IG A4¹⁾



→ Stainless steel A4/316; Through Fastening

→ Approved for cracked and non-cracked concrete

Description	Ref. No.	Drill hole Ø x depth mm	Drill hole depth through fixture mm	Fixture thickness t _{fix} mm		Anchor length l mm	Thread Ø x length mm	Pkg. content pcs	Weight per pkg. kg
				Typ S-IG	Typ SK-IG				
BZ-IG M 6-10 A4	03602501	8 x 60	74	10	14	60	M6 x 20	100	1,80
BZ-IG M 6-20 A4	03604501	8 x 60	84	20	24	70	M6 x 20	100	2,20
BZ-IG M 6-30 A4	03606501	8 x 60	94	30	34	80	M6 x 20	100	2,60
BZ-IG M 8-10 A4	03611501	10 x 75	90	10	15	72	M8 x 22	50	1,65
BZ-IG M 8-20 A4	03612501	10 x 75	100	20	25	82	M8 x 22	50	1,95
BZ-IG M 8-30 A4	03613501	10 x 75	110	30	35	92	M8 x 22	50	2,25
BZ-IG M 10-10 A4	03621501	12 x 90	106	10	16	80	M10 x 23	25	1,32
BZ-IG M 10-20 A4	03622501	12 x 90	116	20	26	90	M10 x 23	25	1,48
BZ-IG M 10-30 A4	03623501	12 x 90	126	30	36	100	M10 x 23	25	1,76
BZ-IG M 12-10 A4	03631501	16 x 105	122	10	17	96	M12 x 27	20	2,34
BZ-IG M 12-20 A4	03632501	16 x 105	132	20	27	106	M12 x 27	20	2,66
BZ-IG M 12-30 A4	03633501	16 x 105	142	30	37	116	M12 x 27	20	2,97

Coated Screw DIN 933 with Washer DIN EN ISO 7089 (DIN 125)¹⁾



Description	Ref. No.	Pkg. content pcs	Weight per pcs. kg
S-IG 6x16 A4	54020501	100	0,64
S-IG 8x18 A4	54120501	50	0,68
S-IG 10x20 A4	54220501	25	0,64
S-IG 12x25 A4	54320501	20	0,67

¹⁾Screws to be ordered separately.

Anchor system in high corrosion resistant steel grade 1.4529 on demand.

Coated Countersunk Screw DIN 7991 with Countersunk Washer¹⁾



Description	Ref. No.	Pkg. content pcs	Weight per pcs. kg
SK-IG 6x16 A4 ²⁾	55010501	100	0,64
SK-IG 8x20 A4 ²⁾	55110501	50	0,60
SK-IG 10x25 A4	55210501	25	0,62
SK-IG 12x30 A4	55310501	20	0,80

¹⁾Screws or hex nuts and washers to be ordered separately.

²⁾Screw similar to DIN 7991 with Torx®-drive. Size see page 24.

Anchor system in high corrosion resistant steel grade 1.4529 on demand. Other screw lengths according to DIN 933 on demand.

Setting Tool BZ-IG for Through Fastening



Description	Ref. No.	Weight per pcs. kg
BZ-IGS M 6D	43005155	0,32
BZ-IGS M 8D	43100155	0,33
BZ-IGS M 10D	43200155	0,33
BZ-IGS M 12D	43300155	0,35



Extract from Permissible Service Conditions of European Technical Assessment ETA-99/0010

Approved loads for single anchor without influence of spacing and edge distance.

Total safety factor as per ETAG 001 included (γ_M and γ_F). Load capacities under fire exposure see page 162.

Loads and performance data	Wedge Anchor BZ-IG A4	M 6	M 8	M 10	M 12	
cracked concrete						
Mean ultimate loads, tension	C25/30 Num	[kN]	14,1	19,8	28,3	45,9
Mean ultimate loads, shear	C25/30 Vum	[kN]	12,0	12,2	14,9	45,4
Approved loads, tension	C20/25 appr. N	[kN]	2,0	3,6	4,8	7,9
	C25/30 appr. N	[kN]	2,2	3,9	5,2	8,7
	C30/37 appr. N	[kN]	2,4	4,4	5,8	9,7
	C40/50 appr. N	[kN]	2,8	5,0	6,7	11,2
	C50/60 appr. N	[kN]	3,1	5,5	7,4	12,3
non-cracked concrete						
Approved loads, tension	C20/25 appr. N	[kN]	4,8	6,3	7,9	11,9
	C25/30 appr. N	[kN]	5,2	7,0	8,7	13,1
	C30/37 appr. N	[kN]	5,4	7,7	9,7	14,5
	C40/50 appr. N	[kN]	5,4	9,0	11,2	16,8
	C50/60 appr. N	[kN]	5,4	9,8	12,3	18,5
cracked and non-cracked concrete						
Approved loads, shear (Pre-Installation)	\geq C20/25 appr. V	[kN]	3,3	5,3	6,1	13,5
Approved loads, shear (Through Fastening)	\geq C20/25 appr. V	[kN]	4,2	4,3	5,5	16,9
Approved bending moments (Pre-Installation)	appr. M	[Nm]	4,9	12,0	23,9	41,9
Approved bending moments (Through Fastening)	appr. M	[Nm]	16,1	25,3	39,9	109,3
Spacing and edge distance						
Effective anchorage depth	h_{ef}	[mm]	45	58	65	80
Characteristic spacing	$s_{cr, N}$	[mm]	135	174	195	240
Characteristic edge distance	$c_{cr, N}$	[mm]	67,5	87	97,5	120
cracked concrete						
Minimum spacing / for edge distance c	s_{min} / c	[mm]	50 / 60	60 / 80	70 / 100	80 / 120
Minimum edge distance / for spacing s	c_{min} / s	[mm]	50 / 75	60 / 100	70 / 100	80 / 120
non-cracked concrete						
Minimum spacing / for edge distance c	s_{min} / c	[mm]	50 / 80	60 / 100	65 / 120	80 / 160
Minimum edge distance / for spacing s	c_{min} / s	[mm]	50 / 115	60 / 155	70 / 170	100 / 210
Minimum thickness of concrete slab	h_{min}	[mm]	100	120	130	160
Installation parameters						
Drill hole diameter	d_o	[mm]	8	10	12	16
Diameter of clearance hole in the fixture - Pre-Installation	d_f	[mm]	7	9	12	14
Diameter of clearance hole in the fixture - Through Fastening	d_f	[mm]	9	12	14	18
Depth of drill hole	h_i	[mm]	60	75	90	105
Installation torque	Screw DIN 933	T_{inst} [Nm]	15	40	50	100
	Countersunk screw	T_{inst} [Nm]	12	25	45	60
	Threaded rod	T_{inst} [Nm]	8	25	40	80
Width across nut	Screw DIN 933 SW	[mm]	10	13	17	19
Internal hexagon size	Countersunk screw SW	[mm]	-	-	6	8
Torx® size	Countersunk screw		T30	T40	-	-
Min. thickness of fixture	Screw DIN 933 or Threaded rod	$t_{fix} \geq$ [mm]	1 / 5 ¹⁾	1 / 7 ¹⁾	1 / 8 ¹⁾	1 / 9 ¹⁾
Min. thickness of fixture	Countersunk screw	$t_{fix} \geq$ [mm]	5 / 9 ¹⁾	7 / 12 ¹⁾	8 / 14 ¹⁾	9 / 16 ¹⁾

¹⁾Pre-Installation / Through Installation. For anchor designing, an easy to operate CD-ROM is available on request or can be downloaded at www.mkt.de.

Pre-installation:

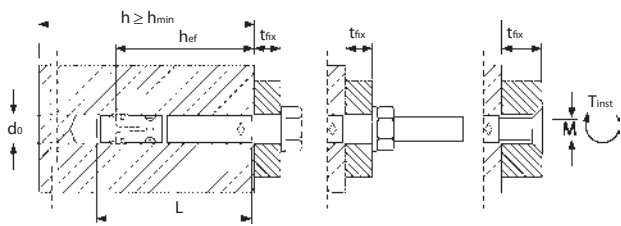

Through fastening:

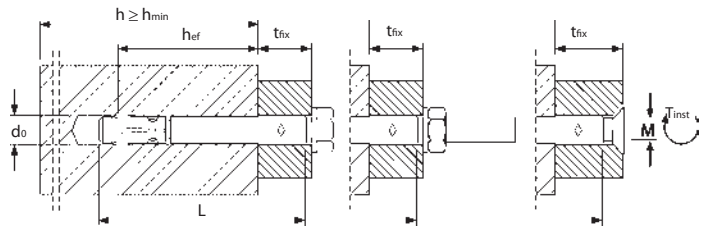

Installation (Pre-installation)

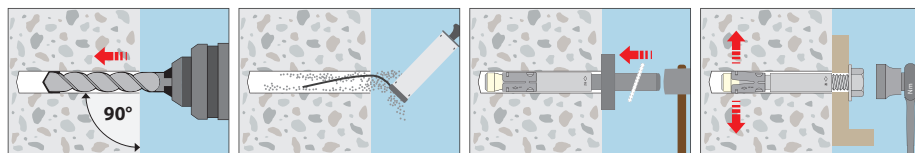

Installation (Through fastening)

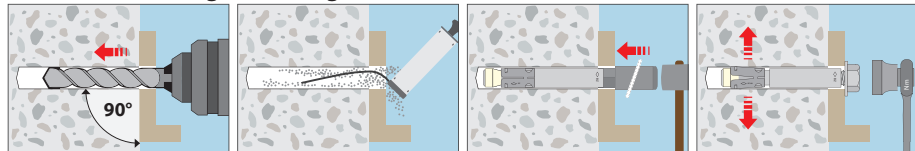

Dimension countersunk washer [mm]

	d1	d2	h
SK M 6	16,5	9,5	3,9
SK M 8	20,5	11,5	5,0
SK M 10	24,5	14,5	5,7
SK M 12	29,5	17,5	6,7

Countersunk head

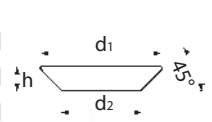

Wedge Anchor B

Steel, zinc plated

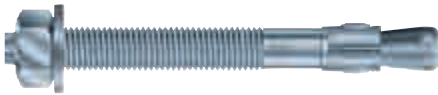

Range of loading: 2,9 kN - 37,2 kN

Range of concrete quality: C20/25 - C50/60

Description

The tried and tested wedge anchor B with European Technical Assessment, Option 7, is ideal for time-saving through fastenings in non-cracked concrete.

Its two effective anchorage depths make it very flexible, reducing contacts with reinforcements when holes are drilled. The long thread also makes stand-off fastenings possible. The hot dip galvanised version is also included in the approval, like the B-U version with the extra large washer for timber structures.



Approvals and Certificates



Advantages

- Approved for use in non-cracked concrete
- Very high load limits and small spacings and edge distances
- Two effective anchorage depths for greater flexibility
- The smaller effective anchorage depth helps to reduce drilling and installation time
- The standard effective anchorage depth is suitable for fastenings under the highest load limits and small spacings and edge distances
- Particularly cost effective: shorter lengths with only one (smaller) anchorage depth
- Suitable for surface, through and stand-off fastenings
- All sizes covered by the approval are assembled with a stainless steel expansion clip
- Fire tested for fire resistance ratings F30-F120
- US approval (FM) for the installation of sprinkler systems (M10 to M16)
- An impact head protects the thread from damage when it is driven into the drilled hole

Applications

Metal constructions, channels, brackets, supports, hand rails, cable trays, ducts, shelf bases.

Wedge Anchor B



- Steel, zinc plated
- Approved for non-cracked concrete

Description	Ref. No.	Standard anchorage depth				Reduced anchorage depth				Anchor length l mm	Thread mm	Pkg. content pcs.	Weight per pkg. kg
		Fixture thickness t _{fix} mm	Drill hole Ø x depth mm	Setting depth h _{nom} mm	Anchorage depth h _{ef} mm	Fixture thickness t _{fix,red} mm	Drill hole Ø x depth mm	Setting depth h _{nom,red} mm	Anchorage depth h _{ef,red} mm				
B 6-5/40 ¹⁾	01005101	-	-	-	-	5	6x35	27	18	40	M6x16	100	1,05
B 6-5/52	01006101	-	-	-	-	5	6x45	39	30	52	M6x20	100	1,26
B 6-10-20/67	01010101	10	6x55	49	40	20	6x45	39	30	67	M6x30	100	1,55
B 6-15-25/72	01013101	15	6x55	49	40	25	6x45	39	30	72	M6x35	100	1,63
B 6-25-35/82	01015101	25	6x55	49	40	35	6x45	39	30	82	M6x35	100	1,81
B 6-40-50/97	01025101	40	6x55	49	40	50	6x45	39	30	97	M6x35	100	2,07
B 8-5/50 ¹⁾	01105101	-	-	-	-	5	8x45	35	24	50	M8x22	100	2,32
B 8-4/60	01110101	-	-	-	-	4	8x55	47	35	60	M8x25	100	2,62
B 8-10-19/75	01115101	10	8x65	56	44	19	8x55	47	35	75	M8x40	100	3,10
B 8-15-24/80	01120101	15	8x65	56	44	24	8x55	47	35	80	M8x45	100	3,26
B 8-20-29/85	01125101	20	8x65	56	44	29	8x55	47	35	85	M8x50	100	3,40
B 8-25-34/90	01130101	25	8x65	56	44	34	8x55	47	35	90	M8x55	100	3,59
B 8-30-39/95	01135101	30	8x65	56	44	39	8x55	47	35	95	M8x60	100	3,72
B 8-35-44/100	01140101	35	8x65	56	44	44	8x55	47	35	100	M8x65	100	3,89
B 8-45-54/110	01145101	45	8x65	56	44	54	8x55	47	35	110	M8x75	100	4,22
B 8-55-64/120	01150101	55	8x65	56	44	64	8x55	47	35	120	M8x85	100	4,54
B 8-100-109/165	01158101	100	8x65	56	44	109	8x55	47	35	165	M8x85	50	2,99
B 10-10/60 ¹⁾	01205101	-	-	-	-	10	10x50	40	25	60	M10x25	50	2,29
B 10-10-16/85	01210101	10	10x70	62	48	16	10x65	56	42	85	M10x40	50	2,83
B 10-15-21/90	01215101	15	10x70	62	48	21	10x65	56	42	90	M10x45	50	2,94
B 10-20-26/95	01220101	20	10x70	62	48	26	10x65	56	42	95	M10x50	50	3,06
B 10-30-36/105	01225101	30	10x70	62	48	36	10x65	56	42	105	M10x60	50	3,32
B 10-45-51/120	01230101	45	10x70	62	48	51	10x65	56	42	120	M10x75	50	3,72
B 10-50-56/125	01235101	50	10x70	62	48	56	10x65	56	42	125	M10x80	50	3,85
B 10-70-76/145	01240101	70	10x70	62	48	76	10x65	56	42	145	M10x80	50	4,35
B 10-100-106/175	01245101	100	10x70	62	48	106	10x65	56	42	175	M10x80	50	5,10
B 10-140-146/215	01250101	140	10x70	62	48	146	10x65	56	42	215	M10x80	25	3,06
B 12-5/75 ¹⁾	01305101	-	-	-	-	5	12x65	55	38	75	M12x30	25	1,98
B 12-13/95	01310101	-	-	-	-	13	12x75	67	50	95	M12x50	25	2,33
B 12-10-25/105	01312101	10	12x90	82	65	25	12x75	67	50	105	M12x60	25	2,55
B 12-15-30/110	01315101	15	12x90	82	65	30	12x75	67	50	110	M12x65	25	2,60
B 12-20-35/115	01320101	20	12x90	82	65	35	12x75	67	50	115	M12x70	25	2,70
B 12-30-45/125	01325101	30	12x90	82	65	45	12x75	67	50	125	M12x80	25	2,88
B 12-50-65/145	01330101	50	12x90	82	65	65	12x75	67	50	145	M12x100	25	3,26
B 12-65-80/160	01335101	65	12x90	82	65	80	12x75	67	50	160	M12x100	25	3,49
B 12-85-100/180	01340101	85	12x90	82	65	100	12x75	67	50	180	M12x100	25	3,90
B 12-105-120/200	01345101	105	12x90	82	65	120	12x75	67	50	200	M12x100	25	4,22
B 12-125-140/220	01350101	125	12x90	82	65	140	12x75	67	50	220	M12x80	25	5,04
B 12-145-160/240	01355101	145	12x90	82	65	160	12x75	67	50	240	M12x80	20	4,38
B 12-160-175/255	01365101	160	12x90	82	65	175	12x75	67	50	255	M12x80	20	4,68
B 12-190-205/285	01370101	190	12x90	82	65	205	12x75	67	50	285	M12x80	20	5,21
B 12-230-245/325	01375101	230	12x90	82	65	245	12x75	67	50	325	M12x80	20	5,90
B 12-260-275/355	01380101	260	12x90	82	65	275	12x75	67	50	355	M12x80	20	6,53
B 16-5/90 ¹⁾	01505101	-	-	-	-	5	16x75	65	47	90	M16x35	20	3,32
B 16-13/115	01510101	-	-	-	-	13	16x95	84	64	115	M16x60	20	3,98
B 16-10-28/130	01512101	10	16x110	102	82	28	16x95	84	64	130	M16x70	20	4,50
B 16-30-48/150	01515101	30	16x110	102	82	48	16x95	84	64	150	M16x90	20	4,87
B 16-60-78/180	01520101	60	16x110	102	82	78	16x95	84	64	180	M16x110	20	5,66
B 16-80-98/200	01525101	80	16x110	102	82	98	16x95	84	64	200	M16x110	10	3,12
B 16-100-118/220	01530101	100	16x110	102	82	118	16x95	84	64	220	M16x80	10	3,64
B 16-130-148/250	01535101	130	16x110	102	82	148	16x95	84	64	250	M16x80	10	4,10
B 16-165-183/285	01540101	165	16x110	102	82	183	16x95	84	64	285	M16x80	10	4,68
B 16-200-218/320	01545101	200	16x110	102	82	218	16x95	84	64	320	M16x80	10	5,23
B 20-10/120 ¹⁾	01604101	-	-	-	-	10	20x100	90	67	120	M20x50	10	3,17
B 20-5-27/150	01605101	5	20x130	121	100	27	20x110	99	78	150	M20x70	10	3,78
B 20-20-42/165	01607101	20	20x130	121	100	42	20x110	99	78	165	M20x70	10	4,12
B 20-35-57/180	01610101	35	20x130	121	100	57	20x110	99	78	180	M20x70	10	4,44
B 20-60-82/205	01612101	60	20x130	121	100	82	20x110	99	78	205	M20x70	10	4,94
B 20-95-117/240	01615101	95	20x130	121	100	117	20x110	99	78	240	M20x70	10	6,10
B 20-120-142/265	01622101	120	20x130	121	100	142	20x110	99	78	265	M20x70	10	6,65

¹⁾Not part of assessment, expansion clip steel, zinc plated.

Wedge Anchor B-U



→ Steel, zinc plated; Large washer DIN EN ISO 7094 (formerly DIN 440)

→ Approved for non-cracked concrete

Description	Ref. No.	Standard anchorage depth				Reduced anchorage depth				Anchor length l mm	Thread mm	Pkg. content pcs.	Weight per pkg. kg
		Fixture thickness t _{fix} mm	Drill hole Ø x depth mm	Setting depth h _{nom} mm	Anchorage depth h _{ef} mm	Fixture thickness t _{fix,red} mm	Drill hole Ø x depth mm	Setting depth h _{nom,red} mm	Anchorage depth h _{ef,red} mm				
B-U 12-85-100/180 ¹⁾	01340701	85	12x90	82	65	100	12x75	67	50	180	M12x100	25	4,74
B-U 12-105-120/200 ¹⁾	01345701	105	12x90	82	65	120	12x75	67	50	200	M12x100	25	5,05
B-U 12-125-140/220 ¹⁾	01350701	125	12x90	82	65	140	12x75	67	50	220	M12x80	25	5,90
B-U 12-145-160/240 ¹⁾	01355701	145	12x90	82	65	160	12x75	67	50	240	M12x80	20	5,09
B-U 12-160-175/255 ¹⁾	01365701	160	12x90	82	65	175	12x75	67	50	255	M12x80	20	5,36
B-U 12-190-205/285 ¹⁾	01370701	190	12x90	82	65	205	12x75	67	50	285	M12x80	20	5,88
B-U 12-230-245/325 ¹⁾	01375701	230	12x90	82	65	245	12x75	67	50	325	M12x80	20	6,56
B-U 12-260-275/355 ¹⁾	01380701	260	12x90	82	65	275	12x75	67	50	355	M12x80	10	3,48
B-U 12-300-315/395 ¹⁾	01385701	300	12x90	82	65	315	12x75	67	50	395	M12x80	20	7,80
B-U 12-335-350/430 ¹⁾	01390701	335	12x90	82	65	350	12x75	67	50	430	M12x80	20	8,00
B-U 16-80-98/200 ²⁾	01525701	80	16x110	102	82	98	16x95	84	64	200	M16x110	10	3,75
B-U 16-100-118/220 ²⁾	01530701	100	16x110	102	82	118	16x95	84	64	220	M16x80	10	4,25
B-U 16-130-148/250 ²⁾	01535701	130	16x110	102	82	148	16x95	84	64	250	M16x80	10	4,72
B-U 16-165-183/285 ²⁾	01540701	165	16x110	102	82	183	16x95	84	64	285	M16x80	10	5,32
B-U 16-200-218/320 ²⁾	01545701	200	16x110	102	82	218	16x95	84	64	320	M16x80	10	5,95
B-U 16-220-238/340 ²⁾	01550701	220	16x110	102	82	238	16x95	84	64	340	M16x80	10	6,16
B-U 16-260-278/380 ²⁾	01557701	260	16x110	102	82	278	16x95	84	64	380	M16x80	10	6,75
B-U 16-300-318/420 ²⁾	01560701	300	16x110	102	82	318	16x95	84	64	420	M16x80	10	7,35

¹⁾Ø washer M12 DIN EN ISO 7094 = 44 mm, thickness 4mm

²⁾Ø washer M16 DIN EN ISO 7094 = 56 mm, thickness 5mm



Extract from Permissible Service Condition of European Technical Assessment ETA-01/0013.

Approved loads for single anchor without influence of spacing and edge distance.

Total safety factor as per ETAG 001 included (γ_M and γ_P). Load capacities under fire exposure see page 166.

Loads and performance data			Wedge Anchor B		M 6		M 8		M 10		M 12		M 16		M 20	
Standard anchorage depth	h_{ef}	[mm]	40	-	44	-	48	-	65	-	82	-	100	-		
Reduced anchorage depth	$h_{ef, red}$	[mm]	-	30 ¹⁾	-	35 ¹⁾	-	42	-	50	-	64	-	78	-	
non-cracked concrete																
Mean ultimate loads, tension	C25/30 Num	[kN]	12	9,6	18,7	12,3	23,6	19,2	34,5	26,1	51,4	43,6	70,0	53,6		
Mean ultimate loads, shear	C25/30 Vum	[kN]	7,3	7,3	19,3	19,3	28,1	28,1	41,3	41,3	73,0	73,0	103,6	103,6		
non-cracked concrete																
Approved loads, tension	C20/25 appr. N	[kN]	4,1	2,9	5,7	5,0	7,6	6,5	12,6	8,5	17,9	12,3	24,0	16,6		
	C25/30 appr. N	[kN]	4,1	3,1	6,3	5,5	8,4	7,2	13,8	9,3	19,6	13,5	26,3	18,1		
	C30/37 appr. N	[kN]	4,1	3,5	7,0	6,1	9,3	8,0	15,3	10,4	21,7	15,0	29,3	20,2		
	C40/50 appr. N	[kN]	4,1	4,0	7,3	7,0	10,7	9,2	16,7	12,0	25,3	17,4	34,0	23,4		
	C50/60 appr. N	[kN]	4,1	4,1	7,3	7,3	11,8	10,1	16,7	13,2	27,7	19,1	37,3	25,7		
Approved loads, shear	C20/25 appr. V	[kN]	2,9	2,9	6,3	5,0	8,0	6,5	14,3	8,5	23,6	23,6	37,1	33,1		
	\geq C25/30 appr. V	[kN]	2,9	2,9	6,3	5,5	8,8	7,2	14,3	9,3	23,6	23,6	37,1	36,3		
Approved bending moments	appr. M	[Nm]	5,1	5,1	13,1	13,1	25,7	25,7	44,6	44,6	99,9	99,9	195,0	195,0		
Spacing and edge distance																
Effective anchorage depth	h_{ef}	[mm]	40	30 ¹⁾	44	35 ¹⁾	48	42	65	50	82	64	100	78		
Characteristic spacing	$s_{cr, N}$	[mm]	120	90	132	105	144	126	195	150	246	192	300	234		
Characteristic edge distance	$c_{cr, N}$	[mm]	60	45	66	52,5	72	63	97,5	75	123	96	150	117		
non-cracked concrete																
Minimum spacing	s_{min}	[mm]	35	35	40	40	55	55	75	100	90	100	105	140		
Minimum edge distance	c_{min}	[mm]	40	40	45	45	65	65	90	100	105	100	125	140		
Minimum thickness of concrete slab	h_{min}	[mm]	100	80	100	80	100	100	130	100	170	130	200	160		
Installation parameters																
Drill hole diameter	d_o	[mm]	6	6	8	8	10	10	12	12	16	16	20	20		
Diameter of clearance hole in the fixture	d_f	[mm]	7	7	9	9	12	12	14	14	18	18	22	22		
Depth of drill hole	h_1	[mm]	55	45	65	55	70	65	90	75	110	95	130	110		
Installation torque	T_{inst}	[Nm]	8	8	15	15	30	30	50	50	100	100	200	200		
Width across nut	SW	[mm]	10	10	13	13	17	17	19	19	24	24	30	30		

¹⁾Application limited to statically indetermined systems.

For anchor designing, an easy to operate CD-ROM is available on request or can be downloaded at www.mkt.de.

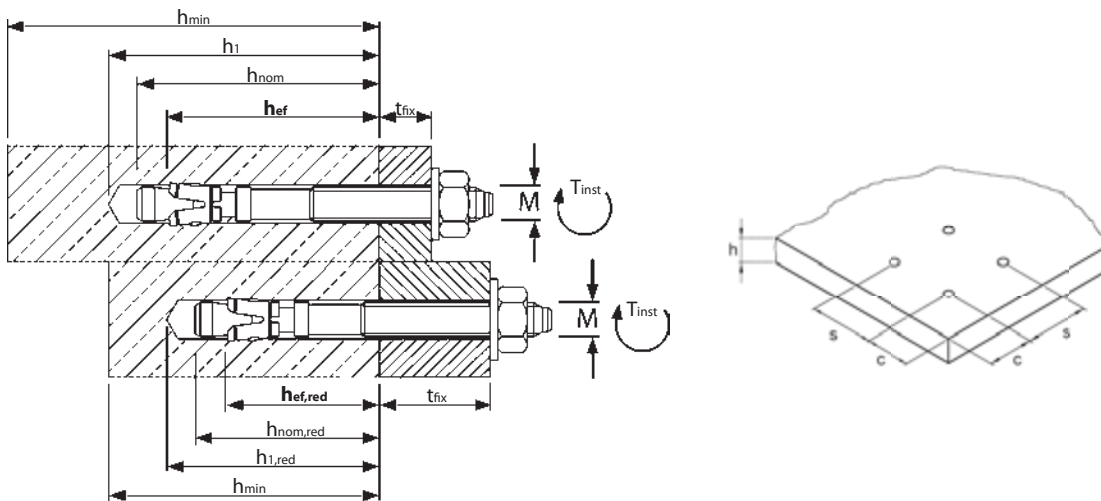

Installation

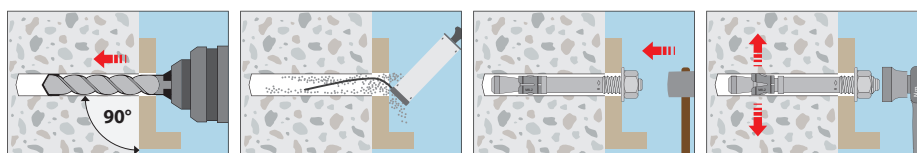

Wedge Anchor B A4 / B HCR

Stainless steel A4/316 and Stainless steel 1.4529



Range of loading: 2,9 kN - 43,9 kN
Range of concrete quality: C20/25 - C50/60



Description

The tried and tested wedge anchor B with European Technical Assessment, Option 7, is ideal for time-saving through fastenings in non-cracked concrete. Its two effective anchorage depths make it very flexible, reducing contacts with reinforcements when holes are drilled. The long thread also makes stand-off fastenings possible.

The wedge anchor B M6 and HCR is also approved for multiple use for non-structural applications and similar fixtures in cracked and non-cracked concrete.

Advantages

- Approved for use in non-cracked concrete
- Very high load limits and small spacings and edge distances
- Two effective anchorage depths for greater flexibility
- The smaller effective anchorage depth helps to reduce drilling and installation time
- The standard effective anchorage depth is suitable for fastenings under the highest load limits and small spacings and edge distances
- Particularly cost effective: shorter lengths with only one (smaller) anchorage depth
- Suitable for surface, through, and stand-off fastenings
- Fire tested for fire resistance ratings F30–F120
- US approval (FM) for the installation of sprinkler systems (M10 to M16)
- An impact head protects the thread from damage when it is driven into the drilled hole

Approvals and Certificates



Applications

Medium to heavy duty indoor and outdoor use, metal structures, brackets, machines.

Wedge Anchor B M6 A4 and HCR: Multiple use for non-structural applications and similar fixtures in tunnels and or external atmospheric exposures.

Wedge Anchor B A4



→ Stainless steel A4/316

→ ETA approval for non-cracked concrete

Description	Ref. No.	Standard anchorage depth				Reduced anchorage depth				Anchor length	Thread	Pkg. content	Weight per pkg.
		Fixture thickness t _{fix} mm	Drill hole Ø x Depth mm	Setting Depth h _{nom} mm	Anchorage depth h _{ef} mm	Fixture thickness t _{fix,red} mm	Drill hole Ø x depth mm	Setting Depth h _{nom,red} mm	Anchorage depth h _{ef,red} mm				
B 6-5/40 A4 ¹⁾	01005501	-	-	-	-	5	6x35	27	18	40	M6x16	100	1,06
B 6-5/52 A4	01006501	-	-	-	-	5	6x45	39	30	52	M6x20	100	1,27
B 6-10-20/67 A4	01010501	10	6x55	49	40	20	6x45	39	30	67	M6x30	100	1,56
B 6-25-35/82 A4	01015501	25	6x55	49	40	35	6x45	39	30	82	M6x35	100	1,80
B 6-40-50/97 A4	01025501	40	6x55	49	40	50	6x45	39	30	97	M6x35	100	2,08
B 8-5/50 A4 ¹⁾	01105501	-	-	-	-	5	8x45	35	24	50	M8x22	100	2,34
B 8-4/60 A4	01110501	-	-	-	-	4	8x55	47	35	60	M8x25	100	2,64
B 8-10-19/75 A4	01115501	10	8x65	56	44	19	8x55	47	35	75	M8x40	100	3,10
B 8-15-24/80 A4	01120501	15	8x65	56	44	24	8x55	47	35	80	M8x45	100	3,28
B 8-20-29/85 A4	01125501	20	8x65	56	44	29	8x55	47	35	85	M8x50	100	3,42
B 8-30-39/95 A4	01135501	30	8x65	56	44	39	8x55	47	35	95	M8x60	100	3,73
B 8-45-54/110 A4	01145501	45	8x65	56	44	54	8x55	47	35	110	M8x75	100	4,20
B 8-55-64/120 A4	01150501	55	8x65	56	44	64	8x55	47	35	120	M8x85	100	4,57
B 10-10/60 A4 ¹⁾	01205501	-	-	-	-	10	10x50	40	25	60	M10x25	50	2,30
B 10-10-16/85 A4	01210501	10	10x70	62	48	16	10x65	56	42	85	M10x40	50	2,85
B 10-15-21/90 A4	01215501	15	10x70	62	48	21	10x65	56	42	90	M10x45	50	2,97
B 10-20-26/95 A4	01220501	20	10x70	62	48	26	10x65	56	42	95	M10x50	50	3,10
B 10-30-36/105 A4	01225501	30	10x70	62	48	36	10x65	56	42	105	M10x60	50	3,33
B 10-45-51/120 A4	01230501	45	10x70	62	48	51	10x65	56	42	120	M10x75	50	3,75
B 10-50-56/125 A4	01235501	50	10x70	62	48	56	10x65	56	42	125	M10x80	50	3,87
B 10-70-76/145 A4	01240501	70	10x70	62	48	76	10x65	56	42	145	M10x80	50	4,38
B 10-100-106/175 A4	01245501	100	10x70	62	48	106	10x65	56	42	175	M10x80	50	5,15
B 10-140-146/215 A4	01250501	140	10x70	62	48	146	10x65	56	42	215	M10x80	25	3,10
B 12-5/75 A4 ¹⁾	01305501	-	-	-	-	5	12x65	55	38	75	M12x30	25	1,96
B 12-14/95 A4	01310501	-	-	-	-	14	12x75	66	50	95	M12x50	25	2,33
B 12-10-25/105 A4	01312501	10	12x90	81	65	25	12x75	66	50	105	M12x60	25	2,53
B 12-15-30/110 A4	01315501	15	12x90	81	65	30	12x75	66	50	110	M12x65	25	2,62
B 12-20-35/115 A4	01320501	20	12x90	81	65	35	12x75	66	50	115	M12x70	25	2,70
B 12-30-45/125 A4	01325501	30	12x90	81	65	45	12x75	66	50	125	M12x80	25	2,88
B 12-50-65/145 A4	01330501	50	12x90	81	65	65	12x75	66	50	145	M12x100	25	3,28
B 12-65-80/160 A4	01335501	65	12x90	81	65	80	12x75	66	50	160	M12x100	25	3,55
B 12-85-100/180 A4	01340501	85	12x90	81	65	100	12x75	66	50	180	M12x100	25	3,90
B 12-105-120/200 A4	01345501	105	12x90	81	65	120	12x75	66	50	200	M12x100	25	4,28
B 12-145-160/240 A4	01355501	145	12x90	81	65	160	12x75	66	50	240	M12x80	20	4,39
B 16-5/90 A4 ¹⁾	01505501	-	-	-	-	5	16x75	65	47	90	M16x35	20	3,37
B 16-14/115 A4	01510501	-	-	-	-	14	16x95	83	64	115	M16x60	20	3,98
B 16-10-26/130 A4	01512501	10	16x110	99	80	26	16x95	83	64	130	M16x70	20	4,34
B 16-30-46/150 A4	01515501	30	16x110	99	80	46	16x95	83	64	150	M16x90	20	4,87
B 16-60-76/180 A4	01520501	60	16x110	99	80	76	16x95	83	64	180	M16x110	20	5,66
B 16-80-96/200 A4	01525501	80	16x110	99	80	96	16x95	83	64	200	M16x110	10	3,26
B 16-100-116/220 A4	01530501	100	16x110	99	80	116	16x95	83	64	220	M16x80	10	3,59
B 16-130-146/250 A4	01535501	130	16x110	99	80	146	16x95	83	64	250	M16x80	10	3,99
B 16-200-216/320 A4	01545501	200	16x110	99	80	216	16x95	83	64	320	M16x80	10	5,16
B 20-5-27/150 A4	01605501	5	20x130	121	100	27	20x110	99	78	150	M20x70	10	3,86
B 20-35-57/180 A4	01610501	35	20x130	121	100	57	20x110	99	78	180	M20x70	10	4,47
B 20-60-82/205 A4	01612501	60	20x130	121	100	82	20x110	99	78	205	M20x70	10	5,03
B 20-95-117/240 A4	01615501	95	20x130	121	100	117	20x110	99	78	240	M20x70	10	6,26

¹⁾Not part of assessment. HCR on demand.

Wedge Anchor B HCR



→ High corrosion resistant steel 1.4529 (HCR)

→ Approved for multiple use for non-structural applications

Description	Ref. No.	Standard anchorage depth				Reduced anchorage depth				Anchor length	Thread	Pkg. content	Weight per pkg.
		Fixture thickness t _{fix} mm	Drill hole Ø x depth mm	Setting depth h _{nom} mm	Anchorage depth h _{ef} mm	Fixture thickness t _{fix,red} mm	Drill hole Ø x depth mm	Setting depth h _{nom,red} mm	Anchorage depth h _{ef,red} mm				
B 6-0-10/57 HCR	01007651	0	6x55	49	40	10	6x45	39	30	57	M6x20	100	1,58
B 6-10-20/67 HCR	01010651	10	6x55	49	40	20	6x45	39	30	67	M6x20	100	1,78
B 6-25-35/82 HCR	01015651	25	6x55	49	40	35	6x45	39	30	82	M6x20	100	2,13
B 6-40-50/97 HCR	01025651	40	6x55	49	40	50	6x45	39	30	97	M6x20	100	2,35

Other length on demand.



Extract from Permissible Service Conditions of ETA-01/0013 and ETA-06/0155.

Approved loads for single anchor without influence of spacing and edge distance.

Total safety factor as per ETAG 001 included (γ_M and γ_F).

Load capacities under fire exposure see page 166.

Loads and performance data			Wedge Anchor BA4 / HCR		M 6		M 8		M 10		M 12		M 16		M 20	
Standard anchorage depth	h_{ef}	[mm]	40	-	44	-	48	-	65	-	80	-	100	-	100	-
Reduced anchorage depth	$h_{ef, red}$	[mm]	-	30 ¹⁾	-	35 ¹⁾	-	42	-	50	-	64	-	78	-	78
non-cracked concrete																
Mean ultimate loads, tension	C25/30 Num	[kN]	11,0	10,2	19,6	12,4	23,1	17,5	36,4	22,6	53,5	39,7	73,0	53,1		
Mean ultimate loads, shear	C25/30 Vum	[kN]	9,7	9,7	19,5	19,5	31,9	31,9	42,6	42,6	76,9	76,9	110,4	110,4		
cracked concrete (multiple use only)																
Approved loads ³⁾ (any direction)	C20/25 to C50/60 appr. F	[kN]	2,4	1,6	-	-	-	-	-	-	-	-	-	-	-	-
non-cracked concrete																
Approved loads, tension	C20/25 appr. N	[kN]	3,6	2,9	5,7	4,3	7,6	5,7	11,9	8,5	17,2	12,3	24,0	16,6		
	C25/30 appr. N	[kN]	3,9	3,1	6,3	4,7	8,3	6,3	13,0	9,3	18,8	13,5	26,3	18,1		
	C30/37 appr. N	[kN]	4,4	3,5	7,0	5,2	9,3	7,0	14,5	10,3	20,9	15,0	29,3	20,2		
	C40/50 appr. N	[kN]	4,8	4,0	8,1	6,1	10,8	8,1	16,8	12,0	24,3	17,4	34,0	23,4		
	C50/60 appr. N	[kN]	4,8	4,4	8,6	6,6	11,8	8,9	18,4	13,2	26,7	19,1	37,3	25,7		
Approved loads, shear	C20/25 appr. V	[kN]	4,0	4,0	6,9	5,0	8,0	6,5	15,4	8,5	28,6	24,6	43,9	33,1		
	\geq C25/30 appr. V	[kN]	4,0	4,0	6,9	5,5	8,8	7,2	15,4	9,3	28,6	27,0	43,9	36,4		
Approved bending moments	appr. M	[Nm]	5,7	5,7	13,7	13,7	28,0	28,0	48,6	48,6	113,7	113,7	231,6	231,6		
Spacing and edge distance																
Effective anchorage depth	h_{ef}	[mm]	40	30 ¹⁾	44	35 ¹⁾	48	42	65	50	80	64	100	78		
Characteristic spacing	$s_{cr, N}$	[mm]	120/370 ²⁾	90/260 ²⁾	132	105	144	126	195	150	240	192	300	234		
Characteristic edge distance	$c_{cr, N}$	[mm]	60/185 ²⁾	45/130 ²⁾	66	52,5	72	63	97,5	75	120	96	150	117		
cracked concrete (multiple use only)																
Minimum spacing	s_{min}	[mm]	50	50	-	-	-	-	-	-	-	-	-	-	-	-
Minimum edge distance	c_{min}	[mm]	50	50	-	-	-	-	-	-	-	-	-	-	-	-
Minimum thickness of concrete slab	h_{min}	[mm]	80	80	-	-	-	-	-	-	-	-	-	-	-	-
non-cracked concrete																
Minimum spacing	s_{min} / c	[mm]	35/40	35/40	35/65	60/60	45/70	55/65	60/100	100/100	80/120	110/110	100/150	140/140		
Minimum edge distance	c_{min} / s	[mm]	35/60	40/35	45/110	60/60	55/80	65/55	70/100	100/100	80/140	110/110	100/180	140/140		
Minimum thickness of concrete slab	h_{min}	[mm]	100	80	100	80	100	100	130	100	160	130	200	160		
Installation parameters																
Drill hole diameter	d_o	[mm]	6	6	8	8	10	10	12	12	16	16	20	20		
Diameter of clearance hole in the fixture	d_f	[mm]	7	7	9	9	12	12	14	14	18	18	22	22		
Depth of drill hole	h_1	[mm]	55	45	65	55	70	65	90	75	110	95	130	110		
Installation torque	T_{inst}	[Nm]	6/8 ²⁾	6/8 ²⁾	15	15	25	25	50	50	100	100	160	160		
Width across nut	SW	[mm]	10	10	13	13	17	17	19	19	24	24	30	30		

¹⁾ Application limited to statically indetermined systems.

²⁾ For applications according to ETA-01/0013. / For applications according to ETA-06/0155.

For anchor designing, an easy to operate CD-ROM is available on request or can be downloaded at www.mkt.de.

³⁾ The maximum load per fixing point for multiple use for non-structural applications may, depending on national regulations, are below the approved load of the anchor. The approved loads per fixing point are regulated for their respective countries in the ETAG 001, Part 6.

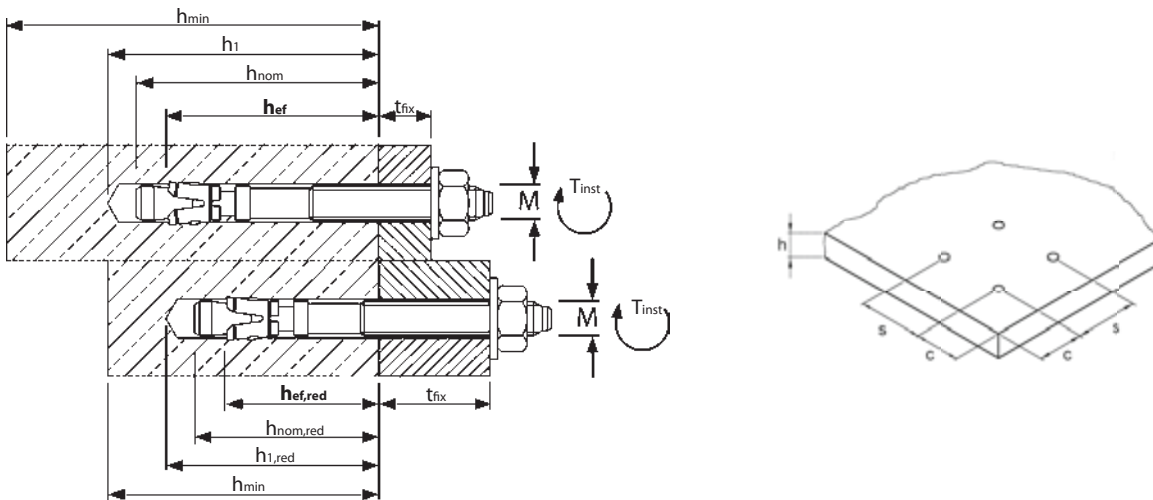

Installation

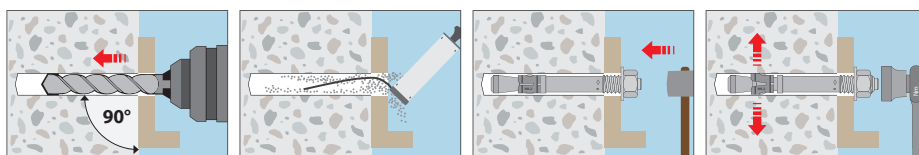

Wedge Anchor B

Hot dip galvanized



Description

The Wedge Anchor B hot dip galvanized, with European Technical Assessment Option 7, offers all the advantages of the zinc plated version with a better corrosion protection. All sizes covered by the Assessment are assembled with a stainless steel expansion clip. Please see also page 26.

Applications

Indoor medium to heavy duty applications: metal constructions, channels, brackets, supports, cladding systems, hand rails, cable trays, ducts.

Range of loading: 2,9 kN - 37,2 kN

Range of concrete quality: C20/25 - C50/60



Wedge Anchor B fvz



→ Steel, hot dip galvanized ($\geq 40\mu\text{m}$, EN ISO 1461)

→ Improved corrosion protection

Description	Ref. No.	Standard anchorage depth				Reduced anchorage depth				Anchor length	Thread	Pkg. content	Weight per pkg.
		Fixture thickness t _{fix} mm	Drill hole Ø x depth mm	Setting depth h _{nom} mm	Anchorage depth h _{ef} mm	Fixture thickness t _{fix,red} mm	Drill hole Ø x depth mm	Setting depth h _{nom,red} mm	Anchorage depth h _{ef,red} mm				
B 6-5/40 fvz ¹⁾	01005201	-	-	-	-	5	6x35	27	18	40	M6x16	100	1,06
B 6-10-20/67 fvz ¹⁾	01010201	10	6x55	49	40	20	6x45	39	30	67	M6x30	100	1,57
B 6-25-35/82 fvz ¹⁾	01015201	25	6x55	49	40	35	6x45	39	30	82	M6x35	100	1,90
B 6-40-50/97 fvz ¹⁾	01025201	40	6x55	49	40	50	6x45	39	30	97	M6x35	100	2,09
B 8-5/50 fvz ¹⁾	01105201	-	-	-	-	5	8x45	35	35	50	M8x22	100	2,36
B 8-4/60 fvz	01110201	-	-	-	-	4	8x55	47	35	60	M8x25	100	2,76
B 8-10-19/75 fvz	01115201	10	8x65	56	44	19	8x55	47	35	75	M8x40	100	3,17
B 8-15-24/80 fvz	01120201	15	8x65	56	44	24	8x55	47	35	80	M8x45	100	3,36
B 8-20-29/85 fvz	01125201	20	8x65	56	44	29	8x55	47	35	85	M8x50	100	3,50
B 8-30-39/95 fvz	01135201	30	8x65	56	44	39	8x55	47	35	95	M8x60	100	3,83
B 8-45-54/110 fvz	01145201	45	8x65	56	44	54	8x55	47	35	110	M8x75	100	4,29
B 8-55-64/120 fvz	01150201	55	8x65	56	44	64	8x55	47	35	120	M8x85	100	4,59
B 10-10/60 fvz ¹⁾	01205201	-	-	-	-	10	10x50	40	24	60	M10x25	50	2,32
B 10-10-16/85 fvz	01210201	10	10x70	62	48	16	10x65	56	42	85	M10x40	50	2,90
B 10-15-21/90 fvz	01215201	15	10x70	62	48	21	10x65	56	42	90	M10x45	50	3,01
B 10-20-26/95 fvz	01220201	20	10x70	62	48	26	10x65	56	42	95	M10x50	50	3,15
B 10-30-36/105 fvz	01225201	30	10x70	62	48	36	10x65	56	42	105	M10x60	50	3,35
B 10-45-51/120 fvz	01230201	45	10x70	62	48	51	10x65	56	42	120	M10x75	50	3,77
B 10-50-56/125 fvz	01235201	50	10x70	62	48	56	10x65	56	42	125	M10x80	50	3,93
B 10-70-76/145 fvz	01240201	70	10x70	62	48	76	10x65	56	42	145	M10x80	50	4,50
B 10-100-106/175 fvz	01245201	100	10x70	62	48	106	10x65	56	42	175	M10x80	50	4,93
B 10-140-146/215 fvz	01250201	140	10x70	62	48	146	10x65	56	42	215	M10x80	25	3,10
B 12-5/75 fvz ¹⁾	01305201	-	-	-	-	5	12x65	55	25	75	M12x30	25	1,99
B 12-13/95 fvz	01310201	-	-	-	-	13	12x75	67	50	95	M12x50	25	2,38
B 12-15-30/110 fvz	01315201	15	12x90	82	65	30	12x75	67	50	110	M12x65	25	2,66
B 12-20-35/115 fvz	01320201	20	12x90	82	65	35	12x75	67	50	115	M12x70	25	2,71
B 12-30-45/125 fvz	01325201	30	12x90	82	65	45	12x75	67	50	125	M12x80	25	2,92
B 12-50-65/145 fvz	01330201	50	12x90	82	65	65	12x75	67	50	145	M12x100	25	3,25
B 12-65-80/160 fvz	01335201	65	12x90	82	65	80	12x75	67	50	160	M12x100	25	3,54
B 12-85-100/180 fvz	01340201	85	12x90	82	65	100	12x75	67	50	180	M12x100	25	3,85
B 12-105-120/200 fvz	01345201	105	12x90	82	65	120	12x75	67	50	200	M12x100	25	4,28
B 16-13/115 fvz	01510201	-	-	-	-	13	16x95	84	38	115	M16x60	20	3,96
B 16-10-28/130 fvz	01512201	10	16x110	102	82	28	16x95	84	64	130	M16x70	20	4,41
B 16-30-48/150 fvz	01515201	30	16x110	102	82	48	16x95	84	64	150	M16x90	20	4,92
B 20-5-27/150 fvz	01605201	5	20x130	121	100	27	20x110	99	78	150	M20x70	10	3,84
B 20-35-57/180 fvz	01610201	35	20x130	121	100	57	20x110	99	78	180	M20x70	10	4,44
B 20-60-82/205 fvz	01612201	60	20x130	121	100	82	20x110	99	78	205	M20x70	10	5,00
B 20-95-117/240 fvz	01615201	95	20x130	121	100	117	20x110	99	78	240	M20x70	10	6,26

¹⁾Not part of assessment.



Extract from Permissible Service Conditions of European Technical Assessment ETA-01/0013

Approved loads for single anchor without influence of spacing and edge distance.

Total safety factor as per ETAG 001 included (γ_M and γ_P). Load capacities under fire exposure see page 162.

Loads and performance data	Wedge Anchor B		M 6 ¹⁾		M 8		M 10		M 12		M 16		M 20	
	hef	[mm]	40	-	44	-	48	-	65	-	82	-	100	-
Standard anchorage depth	hef	[mm]	40	-	44	-	48	-	65	-	82	-	100	-
Reduced anchorage depth	hef, red	[mm]	-	30 ²⁾	-	35 ²⁾	-	42	-	50	-	64	-	78
non-cracked concrete														
Mean ultimate loads, tension	C25/30 Num	[kN]	12,0	9,6	18,7	12,3	23,6	19,2	34,5	26,1	51,4	43,6	70,0	53,6
Mean ultimate loads, shear	C25/30 Vum	[kN]	7,3	7,3	19,3	19,3	28,1	28,1	41,3	41,3	73,0	73,0	103,6	103,6
non-cracked concrete														
Approved loads, tension	C20/25 appr. N	[kN]	4,1	2,9	5,7	5,0	7,6	6,5	12,6	8,5	17,9	12,3	24,0	16,6
	C25/30 appr. N	[kN]	4,1	3,1	6,3	5,5	8,4	7,2	13,8	9,3	19,6	13,5	26,3	18,1
	C30/37 appr. N	[kN]	4,1	3,5	7,0	6,1	9,3	8,0	15,3	10,4	21,7	15,0	29,3	20,2
	C40/50 appr. N	[kN]	4,1	4,0	7,3	7,0	10,7	9,2	16,7	12,0	25,3	17,4	34,0	23,4
	C50/60 appr. N	[kN]	4,1	4,1	7,3	7,3	11,8	10,1	16,7	13,2	27,7	19,1	37,3	25,7
Approved loads, shear	C20/25 appr. V	[kN]	2,9	2,9	6,3	5,0	8,0	6,5	14,3	8,5	23,6	23,6	37,1	33,1
	≥ C25/30 appr. V	[kN]	2,9	2,9	6,3	5,5	8,8	7,2	14,3	9,3	23,6	23,6	37,1	36,3
Approved bending moments	appr. M	[Nm]	5,1	5,1	13,1	13,1	25,7	25,7	44,6	44,6	99,9	99,9	195,0	195,0
Spacing and edge distance														
Effective anchorage depth	hef	[mm]	40	30 ²⁾	44	35 ²⁾	48	42	65	50	82	64	100	78
Characteristic spacing	s _{cr, N}	[mm]	120	90	132	105	144	126	195	150	246	192	300	234
Characteristic edge distance	c _{cr, N}	[mm]	60	45	66	52,5	72	63	97,5	75	123	96	150	117
non-cracked concrete														
Minimum spacing	s _{min}	[mm]	35	35	40	40	55	55	75	100	90	100	105	140
Minimum edge distance	c _{min}	[mm]	40	40	45	45	65	65	90	100	105	100	125	140
Minimum thickness of concrete slab	h _{min}	[mm]	100	80	100	80	100	100	130	100	170	130	200	160
Installation parameters														
Drill hole diameter	d _o	[mm]	6	6	8	8	10	10	12	12	16	16	20	20
Diameter of clearance hole in the fixture	d _f	[mm]	7	7	9	9	12	12	14	14	18	18	22	22
Depth of drill hole	h ₁	[mm]	55	45	65	55	70	65	90	75	110	95	130	110
Installation torque	T _{inst}	[Nm]	8	8	15	15	30	30	40	40	90	90	120	120
Width across nut	SW	[mm]	10	10	13	13	17	17	19	19	24	24	30	30

¹⁾Not part of assessment.

²⁾Application limited to statically indetermined systems.

For anchor designing, an easy to operate CD-ROM is available on request or can be downloaded at www.mkt.de.

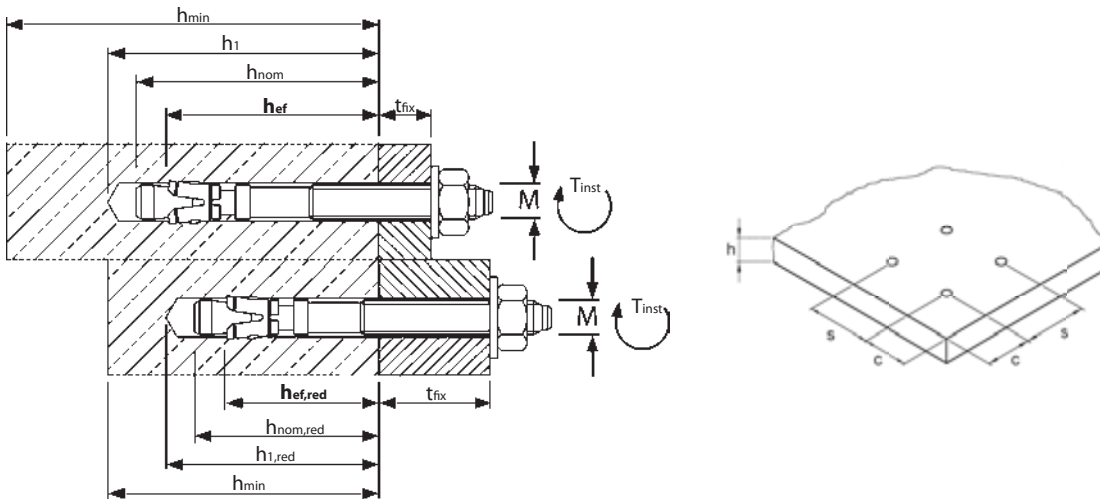

Installation

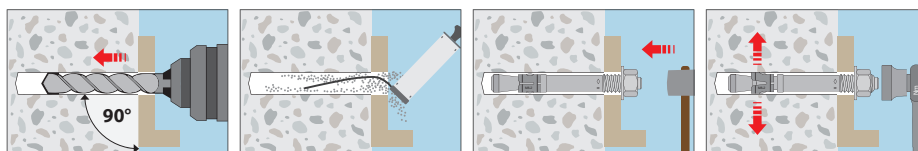

L - Anchor B-W

Steel, zinc plated



Description

The Wedge Anchor B-W is a self expanding hammer-in anchor, designed to attach steel reinforcing mats to existing concrete. The non threaded end is bent to hold the reinforcement mat in place.

Applications

Safe and fast fastening of reinforcing mats for sprayed concrete.

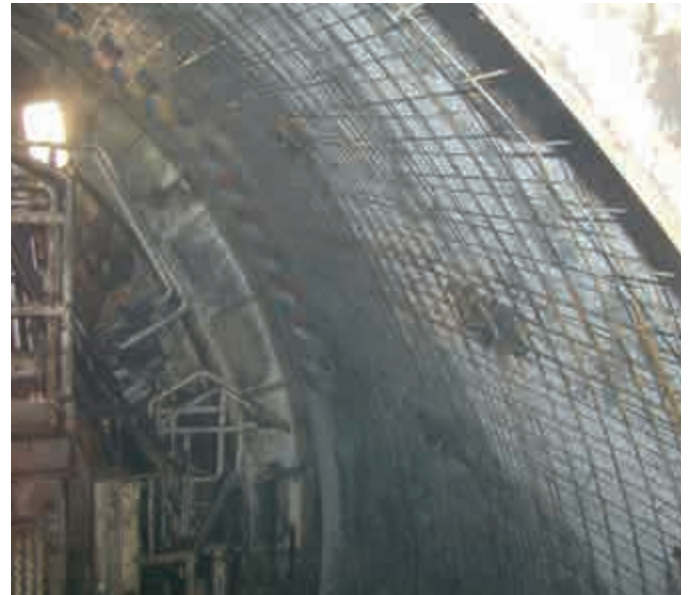

Mechanical Heavy Duty Anchors

L-Anchor B-W



- Steel, zinc plated
- For attaching steel reinforcing mats

Description	Ref. No.	Setting depth h_s mm	Fixture thickness t_{fix} mm	Drill hole \varnothing x depth mm	Bend length l_b mm	Package content pieces	Weight per pck. kg
B-W 8x80x32	93140101	55	20	8 x 65	32	200	6,45
B-W 8x110x35	93148101	55	50	8 x 65	35	200	8,50
B-W 8x140x35	93163101	55	80	8 x 65	35	200	10,50

Other lengths and stainless steel A4/316 on demand.

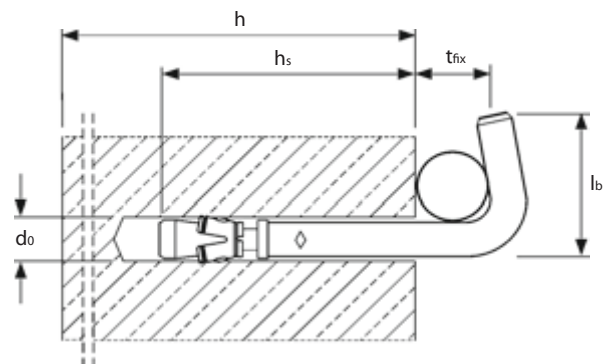

Wedge Anchor B-IG

Steel, zinc plated / Stainless steel A4/316



Wedge Anchor B-IG



Wedge Anchor B-IG A4

Description

The Wedge Anchor B-IG is the internally threaded version of the European approved Wedge Anchor B. It can be installed in normal drill holes without a setting tool. Expansion is achieved by tightening the screw. The fixture can easily be removed. Closer anchor spacing and edge distances than with drop-in anchors.

Applications

Medium duty anchorings where the use of an internal thread is required and/or anchor spacing and edge distances are closer than those needed for drop-in anchors: suspended ceilings, fastening of flat steel structures, ducts, ventilation systems, railings.



Range of loading: 2,9 kN - 15,9 kN

Range of concrete quality: C20/25 - C50/60

Wedge Anchor B-IG



→ Steel, zinc plated

→ With internal thread

Description	Ref. No.	Drill hole Ø x depth mm	Setting depth ¹⁾ mm	Anchor length l mm	Length of screw mm	Thread mm	Package content pcs.	Weight per package kg
B-IG M 6 x 45	03005101	8x60	51	45	t _{fix} +10	M6x15	100	1,39
B-IG M 8 x 50	03105101	10x65	57	50	t _{fix} +12	M8x15	100	2,40
B-IG M 10 x 60	03205101	12x75	71	60	t _{fix} +15	M10x20	50	1,95
B-IG M 12 x 75	03305101	16x95	84	75	t _{fix} +20	M12x26	25	2,29

¹⁾Install Anchor below concrete surface.

Wedge Anchor B-IG A4



→ Stainless steel A4/316

→ With internal thread

Description	Ref. No.	Drill hole Ø x depth mm	Setting depth ¹⁾ mm	Anchor length l mm	Length of screw mm	Thread mm	Package content pcs.	Weight per package kg
B-IG M 6 x 45 A4	03005501	8x60	51	45	t _{fix} +10	M6x15	100	1,41
B-IG M 8 x 50 A4	03105501	10x65	57	50	t _{fix} +12	M8x15	100	2,45
B-IG M 10 x 60 A4	03205501	12x75	71	60	t _{fix} +15	M10x20	50	1,98
B-IG M 12 x 75 A4	03305501	16x95	84	75	t _{fix} +20	M12x26	25	2,23

¹⁾Install Anchor below concrete surface.

Recommended loads for single anchor without influence of spacing and edge distance.
 Total safety factor as per ETAG included (γ_M and γ_F)

Loads and performance data	Wedge Anchor B-IG	M 6x45		M 8x50		M 10x60		M 12x75	
		non-cracked concrete							
		steel 5.8	A4-70	steel 5.8	A4-70	steel 5.8	A4-70	steel 5.8	A4-70
Mean ultimate loads, tension	C25/30 Num [kN]	10,1	14,1	18,3	19,6	24,0	25,3	36,3	37,8
Mean ultimate loads, shear	C25/30 Vum [kN]	5,0	7,0	6,9	12,8	7,2	20,3	21,1	29,5
Recommended loads, tension	C20/25 rec. N [kN]	4,3	4,8	5,6	5,6	7,5	7,5	10,2	10,2
	C25/30 rec. N [kN]	4,3	5,2	6,2	6,2	8,2	8,2	11,3	11,3
	C30/37 rec. N [kN]	4,3	5,3	6,9	6,9	9,1	9,1	12,5	12,5
	C40/50 rec. N [kN]	4,3	5,3	8,0	8,0	10,6	10,6	14,4	14,4
Recommended loads, shear	C50/60 rec. N [kN]	4,3	5,3	8,1	8,7	11,4	11,1	15,9	15,9
	\geq C20/25 rec. V [kN]	2,9	3,2	3,9	5,3	4,1	6,7	14,2	15,8
Recommended bending moments	rec. M [Nm]	4,2	4,9	10,9	12,0	28,0	23,9	45,6	41,9
Spacing and edge distance									
Effective anchorage depth	h_{ef} [mm]	39		43		52		64	
Characteristic spacing	$s_{cr, N}$ [mm]	117		129		156		192	
Characteristic edge distance	$c_{cr, N}$ [mm]	58,5		64,5		78		96	
Minimum spacing	s_{min} [mm]	50		55		75		90	
Minimum edge distance	c_{min} [mm]	50		65		90		105	
Minimum thickness of concrete slab	h_{min} [mm]	100		100		110		130	
Installation parameters									
Drill hole diameter	d_o [mm]	8		10		12		16	
Diameter of clearance hole in the fixture	d_f [mm]	7		9		12		14	
Depth of drill hole	h_1 [mm]	60		65		75		95	
Installation torque	T_{inst} [Nm]	6		15		30		50	

For anchor designing, an easy to operate CD-ROM is available on request or can be downloaded at www.mkt.de.

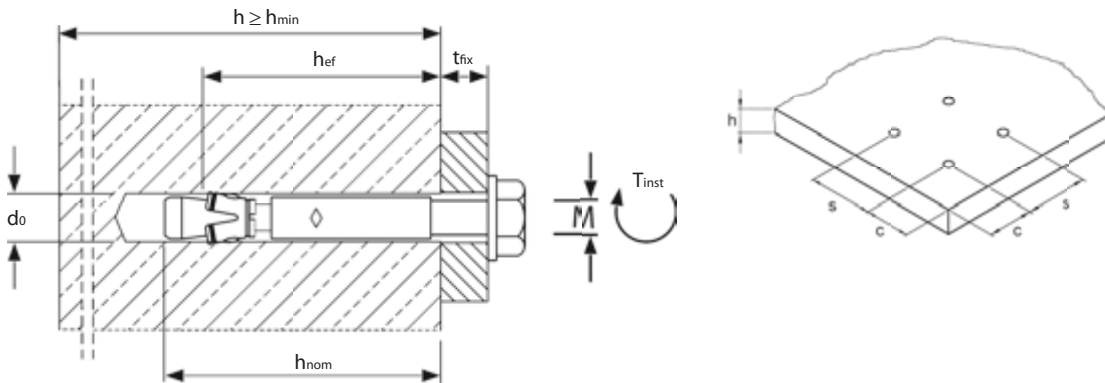

Installation

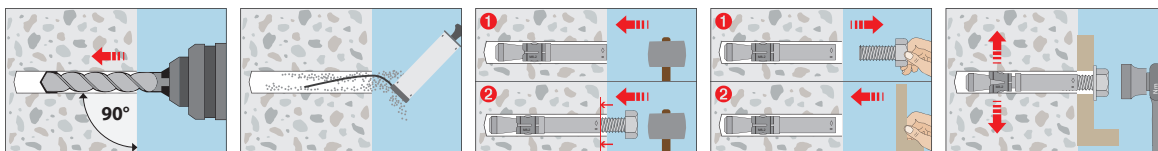

Nail Anchor N

Steel, zinc plated / Stainless steel A4 / HCR

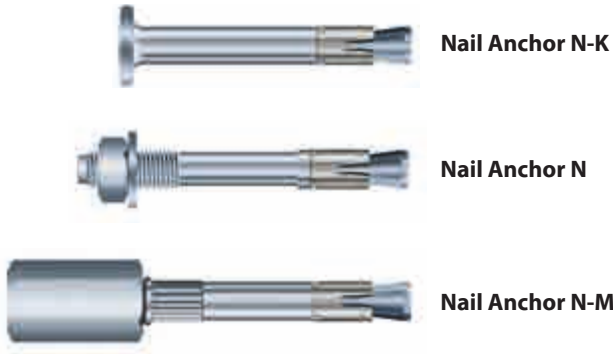

Range of loading: 0,71 kN - 2,81 kN
Range of concrete quality: C12/15 - C50/60



Description

The Nail Anchor N combines the advantages of a wedge anchor with an even easier installation. The Nail Anchor is simply hammered through the fixture into the concrete. Applying torque is not necessary in the threaded versions. When the load is applied the Nail Anchor expands automatically and anchors to the concrete. There is a nail head (N-K) version, a M6 external thread (N) version and a dual threaded sleeve M8/M10 (N-M).

The Nail anchor in stainless Steel A4/316 and stainless Steel HCR is also tested according to ZTV and RWS tunnel temperature curve in cracked concrete. Load capacities see Page 169.

Advantages

- ETA assessment for redundant fastenings in cracked and non-cracked concrete
- Fast and simple mounting
- Reduced anchorage depth (25 mm) for reduced drilling costs
- Very small edge distances and spacings
- Loads up to 2,81 kN
- Only one product for two applications: dual thread M8/M10 (N-M)

Applications

Ceiling constructions, piping, cladding etc.

Nail Anchor N



- Steel, zinc plated
- With thread M6

Description	Ref. No.	Drill hole Ø	Standard anchorage depth			Reduced anchorage depth			Anchor length	Pkg. content	Weight per pkg.
			Fixture thickness t _{fix} mm	Drill hole depth h ₁ mm	Anchorage depth h _{ef} mm	Fixture thickness t _{fix,red} mm	Drill hole depth h _{1,red} mm	Anchorage depth h _{ef,red} mm			
N 6-0-5/44	60005101	6	0	40	30	5	35	25	44	200	2,22
N 6-5-10/49	60010101	6	5	40	30	10	35	25	49	200	2,39
N 6-10-15/54	60015101	6	10	40	30	15	35	25	54	200	2,58

Nail Anchor N-K



- Steel, zinc plated
- With Nailhead

Description	Ref. No.	Drill hole Ø	Standard anchorage depth			Reduced anchorage depth			Anchor length	Pkg. content	Weight per pkg.
			Fixture thickness t _{fix} mm	Drill hole depth h ₁ mm	Anchorage depth h _{ef} mm	Fixture thickness t _{fix,red} mm	Drill hole depth h _{1,red} mm	Anchorage depth h _{ef,red} mm			
N-K 6-0-5/39	60105101	6	0	40	30	5	35	25	39	200	2,24
N-K 6-5-10/44	60110101	6	5	40	30	10	35	25	44	200	2,29
N-K 6-10-15/49	60115101	6	10	40	30	15	35	25	49	200	2,54
N-K 6-15-20/54	60120101	6	15	40	30	20	35	25	54	200	2,74
N-K 6-30-35/69	60135101	6	30	40	30	35	35	25	69	200	3,44
N-K 6-50-55/89	60155101	6	50	40	30	55	35	25	89	100	2,19

Nail Anchor N-M



- Steel, zinc plated
- Connecting thread M8 and M10

Description	Ref. No.	Drill hole	Drill hole depth	Anchorage depth	Anchor length	Pkg. content	Weight per pkg.
		Ø	h ₁	h _{ef}	l		
		mm	mm	mm	mm	pcs	kg
N-M 6-25 M8/10	60310101	6	35	25	58	100	2,75
N-M 6-30 M8/10	60315101	6	40	30	63	100	2,85

Dimensions threaded sleeve N-M:

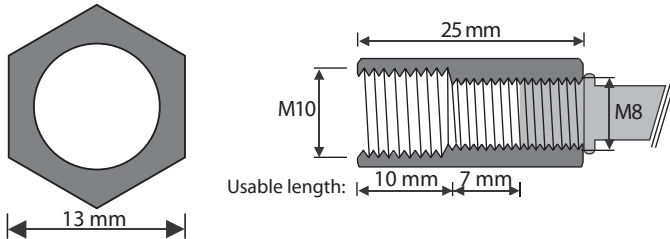

Nail Anchor N A4



- Stainless steel A4
- With thread M6

Description	Ref. No.	Drill hole Ø	Standard anchorage depth			Reduced anchorage depth			Anchor length	Pkg. content	Weight per pkg.
			Fixture thickness t _{fix} mm	Drill hole depth h ₁ mm	Anchorage depth h _{ef} mm	Fixture thickness t _{fix,red} mm	Drill hole depth h _{1,red} mm	Anchorage depth h _{ef,red} mm			
N 6-5/49 A4	61010501	6	5	40	30	-	-	-	49	200	2,39

Nail Anchor N-KA4



- Stainless steel A4
- With Nailhead

Description	Ref. No.	Drill hole Ø	Standard anchorage depth			Reduced anchorage depth ¹⁾			Anchor length	Pkg. content	Weight per pkg.
			Fixture thickness t _{fix} mm	Drill hole depth h ₁ mm	Anchorage depth h _{ef} mm	Fixture thickness t _{fix,red} mm	Drill hole depth h _{1,red} mm	Anchorage depth h _{ef,red} mm			
N-K 6-0/39 A4	61105501	6	0	40	30	5	35	25 ¹⁾	39	200	2,24
N-K 6-5/44 A4	61110501	6	5	40	30	10	35	25 ¹⁾	44	200	2,29
N-K 6-10/49 A4	61115501	6	10	40	30	15	35	25 ¹⁾	49	200	2,54
N-K 6-15/54 A4	61120501	6	15	40	30	20	35	25 ¹⁾	54	200	2,74
N-K 6-20/59 A4	61125501	6	20	40	30	25	35	25 ¹⁾	59	200	2,91
N-K 6-30/69 A4	61135501	6	30	40	30	35	35	25 ¹⁾	69	200	3,44
N-K 6-50/89 A4	61155501	6	50	40	30	55	35	25 ¹⁾	89	100	2,19

¹⁾According to ETAG 001, Part 6 reduced anchorage depth is only permitted for indoor use.

Nail Anchor N HCR



- High corrosion resistant steel 1.4529 (HCR)
- With thread M6

Description	Ref. No.	Drill hole Ø	Standard anchorage depth			Reduced anchorage depth			Anchor length	Pkg. content	Weight per pkg.
			Fixture thickness t _{fix} mm	Drill hole depth h ₁ mm	Anchorage depth h _{ef} mm	Fixture thickness t _{fix,red} mm	Drill hole depth h _{1,red} mm	Anchorage depth h _{ef,red} mm			
N 6-5/49 HCR	61010651	6	5	40	30	-	-	-	49	200	2,39

Nail Anchor N-K HCR



→ High corrosion resistant steel 1.4529 (HCR)

→ With Nailhead

Description	Ref. No.	Drill hole Ø	Standard anchorage depth			Reduced anchorage depth ¹⁾			Anchor length mm	Pkg. content pcs.	Weight per pkg. kg
			Fixture thickness t _{fix} mm	Drill hole depth h ₁ mm	Anchorage depth h _{ef} mm	Fixture thickness t _{fix,red} mm	Drill hole depth h _{1,red} mm	Anchorage depth h _{ef,red} mm			
N-K 6-5/44 HCR	61110651	6	5	40	30	10	35	25 ¹⁾	44	200	2,29
N-K 6-15/54 HCR	61120651	6	15	40	30	20	35	25 ¹⁾	54	200	2,54
N-K 6-30/69 HCR	61135651	6	30	40	30	35	35	25 ¹⁾	69	200	3,44
N-K 6-50/89 HCR	61155651	6	50	40	30	55	35	25 ¹⁾	89	100	2,19

¹⁾According to ETAG 001, Part 6 reduced anchorage depth is only permitted for indoor use.

Setting Tool



→ Setting Tool for Nail Anchor N-K

→ With SDS plus connection

Description	Ref. No.	Pkg. content pcs	Weight per pkg. kg
N-K SWZ SDS	09795101	1	0,05

Installation

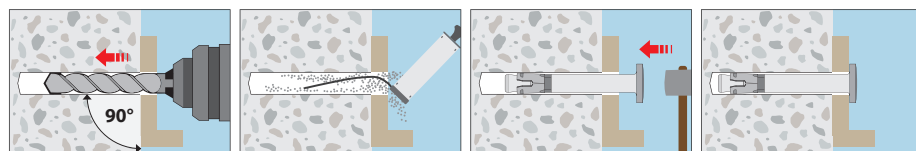



Extract from Permissible Service Conditions of European Technical Assessment ETA-11/0240

Multiple use for non-structural applications. Total safety factor as per ETAG 001 included (γ_M and γ_F). The maximum load per fixing point for multiple use for non-structural applications may, depending on national regulations, be below the approved load of the anchor. The approved loads per fixing point are regulated for their respective countries in the ETAG 001, Part 6. Load capacities under fire exposure see page 166.

Loads and performance data	Nail Anchor steel zinc plated, stainless steel A4, HCR		N 6		N-K		N-M	
			cracked / non-cracked concrete					
Effective anchorage depth	h_{ef}	[mm]	25	30	25	30	25	30
Approved loads (Picture 1)	C12/15 appr. F	[kN]	1,43	1,90	1,43	1,90	1,43 ¹⁾	1,90 ¹⁾
	C20/25 - C50/60 appr. F	[kN]	2,14	2,81	2,14	2,81	2,14 ¹⁾	2,81 ¹⁾
Approved loads (Picture 2)	C12/15 appr. F	[kN]	0,71	0,95	0,71	0,95	0,71 ¹⁾	0,95 ¹⁾
	C20/25 - C50/60 appr. F	[kN]	0,95	1,19	0,95	1,19	0,95 ¹⁾	1,19 ¹⁾
Approved bending moments	appr. M	[Nm]	5,3	5,3	7,3	7,3/7,7 ²⁾	7,3	7,3
Minimum thickness of concrete slab	h_{min}	[mm]	80	80	80	80	80	80
Installation parameters								
Drill hole diameter	d_o	[mm]	6	6	6	6	6	6
Diameter of clearance hole in the fixture	d_r	[mm]	7	7	7	7	7	7
Diameter nailhead		[mm]	-	-	13	13	-	-
Depth of drill hole	h_1	[mm]	35	40	35	40	35	40
Installation torque	$\leq T_{inst}$	[Nm]	4	4	-	-	-	-

¹⁾When applying a shear load to anchor version N-M, shear load with lever arm must be proven.

²⁾Steel zinc plated / stainless steel A4, HCR

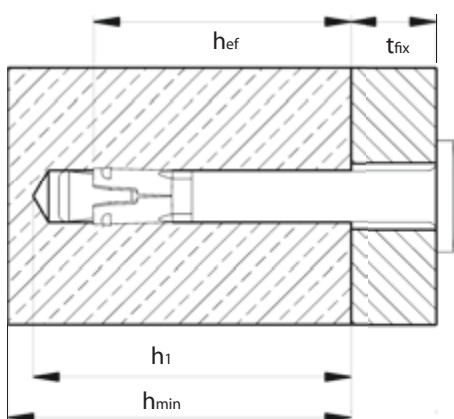

Respective spacing and edge distances [mm]:

The approved load F is for one fixing point.

One fixing point can be:

- **Single anchor,**
- **Pair of anchors** with spacing $s \geq 50$ mm or
- **Group of four anchors** with $s \geq 50$ mm

If the spacing in a fixing point is greater than or equal to the respective spacing between the fixing points, the characteristic resistances apply to every single anchor.

Picture 1: maximum loads

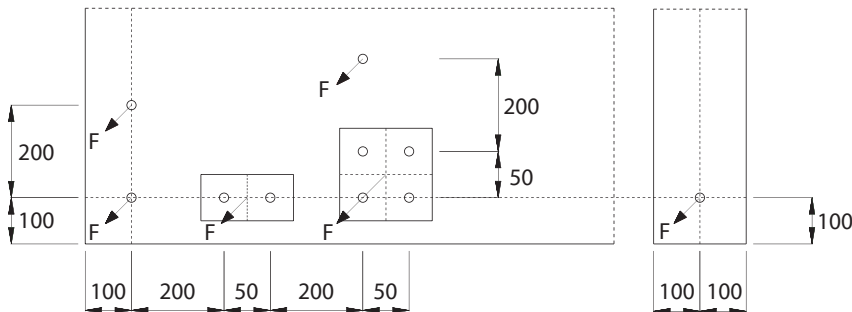

Picture 2: minimum spacing and edge distance

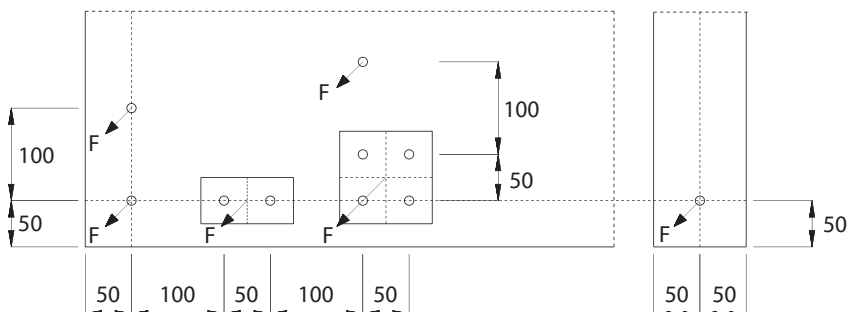

Drop-in Anchor E / ES

Steel, zinc plated



Drop-in Anchor E



Drop-in Anchor ES



Drop-in Anchor ES

Range of loading: 1,2 kN - 28,6 kN
Range of concrete quality: C20/25 - C50/60

Description

The Drop-in Anchor E/ES is approved for redundant fastening for non-structural applications in cracked and non-cracked concrete. The anchor sizes with an embedment of 30 mm deep are also approved as single anchor in non-cracked concrete. The Drop-in Anchors with an anchorage depth of 25 mm are, however, permitted in pre-stressed hollow core slabs.

The Drop-in Anchor E/ES is placed into the drill hole in pre-setting installation and expanded reliably by means of a manual or hammer drill setting tool. Using a detachable setting tool with a stop drill bit (ASW) allows for quick and efficient, high volume installations. Using the marking setting tool produces a visible marking on the anchors-leave which confirms the correct installation.

Advantages

- Approved for use as multiple fixing in cracked and uncracked concrete
- Approved as multiple fixing in pre-stressed concrete slabs
- Approved for use as single fixing in non-cracked concrete (Anchorage depth ≥ 30 mm)
- Shallow drilling depth, thus low risk of hitting reinforcement strikes (Anchorage depth 25 mm)
- Quick, rational and efficient installation due to the detachable setting tool with a stop drill bit (ASW)
- Simple visual inspection with marking tool
- Many possible applications due to the use of standard metric screws and threaded rods
- FM approval for the installation of sprinkler systems (M10-M20)¹⁾
- Suitable for the installation of sprinkler systems according to the requirements of damage prevention VDS, GmbH (M8-M16)²⁾
- Fire resistance tested in concrete C20/25 to C50/60

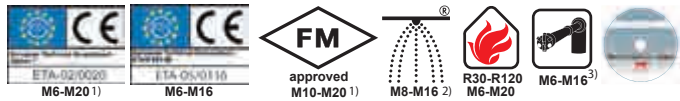

Applications

Suspensions in the area of heating, sanitary and ventilation, anchoring with threaded rods and screws, flat steel, profiled steel.

¹⁾Applies only to anchorage depths $h_{ef} \geq 30$ mm
²⁾Not for applications in pre-stressed hollow core slabs
³⁾Only for multiple use for non-structural applications

Drop-in Anchor E

- Steel, zinc plated
- Approved for concrete

Description	Ref. No.	Drill hole Ø x depth mm	Thread Ø x length mm	Package content pcs.	Weight per package kg
E M 5 x 25 ¹⁾	05000101	8 x 25	M5 x 10	100	0,74
E M 6 x 30	05005101	8 x 30	M6 x 13	100	0,84
E M 8 x 30	05100101	10 x 30	M8 x 13	100	1,17
E M 8 x 40	05105101	10 x 40	M8 x 20	100	1,49
E M 10 x 40	05200101	12 x 40	M10 x 15	50	1,07
E M 12 x 50	05300101	15 x 50	M12 x 18	50	2,18
E M 12 x 80	05305101	15 x 80	M12 x 45	50	3,15
E M 16 x 65	05500101	20 x 65	M16 x 23	25	2,55
E M 16 x 80	05505101	20 x 80	M16 x 38	25	2,91
E M 20 x 80	05600101	25 x 80	M20 x 34	25	4,45

¹⁾Not part of assessment

Drop-in Anchor ES

- Steel, zinc plated/Approved for concrete
- Lipped Drop-in for installations in a bottomless hole

Description	Ref. No.	Drill hole Ø x depth mm	Thread Ø x length mm	Package content pcs.	Weight per package kg
ES M 6x25	05025101	8 x 25	M6 x 12	100	0,74
ES M 8 x 25	05125101	10 x 25	M8 x 12	100	1,05
ES M 8 x 30	05150101	10 x 30	M8 x 13	100	1,15
ES M 8 x 40	05155101	10 x 40	M8 x 20	100	1,53
ES M 10 x 25	05225101	12 x 25	M10 x 12	50	0,80
ES M 10 x 30	05230101	12 x 30	M10 x 12	50	0,89
ES M 10 x 40	05250101	12 x 40	M10 x 15	50	1,10
ES M 12 x 25	05325101	15 x 25	M12 x 12	50	1,15
ES M 12 x 50	05350101	15 x 50	M12 x 18	50	2,15
ES M 16 x 65	05551101	20 x 65	M16 x 23	25	2,53

Safety Setting Tool

For Drop-in Anchor E and ES
With hand guard



Description	Ref. No.	Weight per piece kg
E-MSH 6 x 25	09025801	0,42
E-MSH 8 x 25	09125801	0,42
E-MSH 8 x 30	09100801	0,42
E-MSH 8 x 40	09105801	0,38
E-MSH 10 x 25	09225801	0,50
E-MSH 10 x 30	09205801	0,50
E-MSH 10 x 40	09200801	0,45
E-MSH 12 x 25	09325801	0,45
E-MSH 12 x 50	09300801	0,47
E-MSH 12 x 80	09305801	0,51
E-MSH 16 x 65	09500801	0,50
E-MSH 16 x 80	09505801	0,55
E-MSH 20 x 80	09600801	0,62

Standard Setting Tool

For Drop-in Anchor E and ES



Description	Ref. No.	Weight per piece kg
E-SW 5 x 25	09000150	0,08
E-SW 6 x 25	09002150	0,09
E-SW 6 x 30	09005150	0,09
E-SW 8 x 25	09125150	0,14
E-SW 8 x 30	09100150	0,14
E-SW 8 x 40	09105150	0,14
E-SW 10 x 25	09225150	0,15
E-SW 10 x 30	09205150	0,15
E-SW 10 x 40	09200150	0,15
E-SW 12 x 25	09325150	0,24
E-SW 12 x 50	09300150	0,25
E-SW 12 x 80	09305150	0,22
E-SW 16 x 65	09500150	0,41
E-SW 16 x 80/DW 15	09505150	0,42
E-SW 20 x 80	09600150	0,68

Plug-on setting tool with stop drill bit

For Drop-in Anchor E and ES.



Description	Ref. No.	For Drop-in Anchor	Suitable stop drill bit	Package content pcs.	Weight per piece kg
E-ASW 6 x 25	09097101	ES M 6 x 25	BB 8 x 25	1	0,20
E-ASW 6 x 30	09098101	E/ES M 6 x 30	BB 8 x 30	1	0,20
E-ASW 8 x 25	09197101	ES M 8 x 25	BB 10 x 25	1	0,20
E-ASW 8 x 30	09198101	E/ES M 8 x 30	BB 10 x 30	1	0,20
E-ASW 8 x 40	09199101	E/ES M 8 x 40	BB 10 x 40	1	0,23
E-ASW 10 x 25	09297101	ES M 10 x 25	BB 12 x 25	1	0,21
E-ASW 10 x 30	09298101	E/ES M 10 x 30	BB 12 x 30	1	0,21
E-ASW 10 x 40	09299101	E/ES M 10 x 40	BB 12 x 40	1	0,24

Stop drill bit

For Drop-in Anchor E and ES.



Description	Ref. No.	Drill hole Ø x depth [mm]	For Drop-in Anchor	Suitable for plug-on setting tool	Package content pcs.	Weight per piece kg
BB 8 x 25	50031001	8 x 25	ES M 6 x 25	E-ASW 6 x 25	1	0,11
BB 8 x 30	50031501	8 x 30	E/ES M 6 x 30	E-ASW 6 x 30	1	0,11
BB 10 x 25	50041001	10 x 25	ES M 8 x 25	E-ASW 8 x 25	1	0,11
BB 10 x 30	50041501	10 x 30	E/ES M 8 x 30	E-ASW 8 x 30	1	0,11
BB 10 x 40	50042001	10 x 40	E/ES M 8 x 40	E-ASW 8 x 40	1	0,12
BB 12 x 25	50051001	12 x 25	ES M 10 x 25	E-ASW 10 x 25	1	0,12
BB 12 x 30	50051501	12 x 30	E/ES M 10 x 30	E-ASW 10 x 30	1	0,12
BB 12 x 40	50052001	12 x 40	E/ES M 10 x 40	E-ASW 10 x 40	1	0,12
BB 15 x 25	50071001	15 x 25	ES M 12 x 25	-	1	0,15
BB 15 x 50	50072501	15 x 50	E/ES M 12 x 50	-	1	0,17

SDS Setting Tool

For Drop-in Anchor E and ES. With SDS plus connection.



Description	Ref. No.	Weight per piece kg
E-SW 6 x 25 SDS	09090101	0,07
E-SW 8 x 25 SDS	09185101	0,07
E-SW 8 x 30 SDS	09190101	0,07
E-SW 8 x 40 SDS	09195101	0,07
E-SW 10 x 25 SDS	09286101	0,08
E-SW 10 x 30 SDS	09288101	0,08
E-SW 10 x 40 SDS	09290101	0,08
E-SW 12 x 25 SDS	09395101	0,10
E-SW 12 x 50 SDS	09390101	0,10

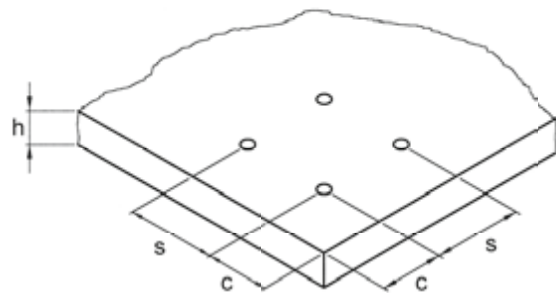
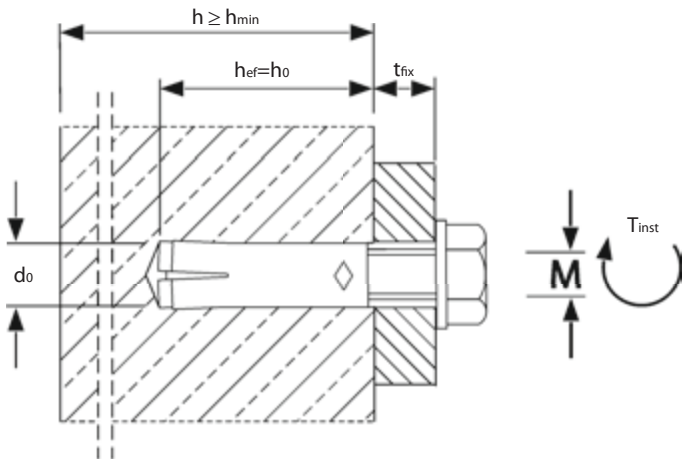

Installation

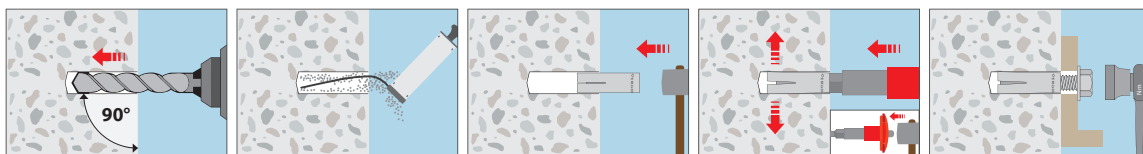



Extract from Permissible Service Conditions of European Technical Assessment ETA-02/0020

Approved loads for single anchor without influence of spacing and edge distance. Total safety factor as per ETAG 001 included (γ_M and γ_P). Load capacities under fire exposure see page 166.

Loads and performance data	Drop-in Anchor E/ES		M5x25 ^{1,2)}	M6x30 ¹⁾	M8x30 ¹⁾	M8x40	M10x30 ¹⁾	M10x40	M12x50 M12x80	M16x65 M16x80	M20x80	non-cracked concrete	
Mean ultimate loads, tension (Screw 8.8)	C25/30 Num	[kN]	8,0	10,0	11,5	13,5	15,6	16,9	24,1	36,4	50,5		
Mean ultimate loads, shear (Screw 8.8)	C25/30 Vum	[kN]	5,7	6,9	11,1	11,1	13,5	13,5	29,5	50,4	76,4		
Approved loads, tension (Screw 5.6 to 8.8)	C20/25 appr. N	[kN]	1,4	3,3	3,3	3,6	3,3	5,1	7,1	10,5	14,3		
	C25/30 appr. N	[kN]	1,5	3,6	3,6	3,8	3,6	5,6	7,8	11,5	15,7		
	C30/37 appr. N	[kN]	1,7	3,6	4,0	4,0	4,0	6,2	8,6	12,8	17,4		
	C40/50 appr. N	[kN]	1,9	3,6	4,7	4,4	4,7	7,2	10,0	14,9	20,3		
	C50/60 appr. N	[kN]	2,1	3,6	5,1	4,6	5,1	7,9	11,0	16,3	22,2		
Approved loads, shear (Screw 5.6)	≥ C20/25 appr. V	[kN]	1,5	2,1	3,9	3,9	4,0	4,1	9,0	16,8	26,2		
Approved loads, shear (Screw 5.8)	≥ C20/25 appr. V	[kN]	2,0	2,9	3,9	3,9	4,0	4,1	11,1	18,0	28,6		
Approved loads, shear (Screw 8.8)	≥ C20/25 appr. V	[kN]	2,0	2,9	3,9	3,9	4,0	4,1	11,1	18,0	28,6		
Approved bending moments (Screw 5.6)	appr. M	[Nm]	-	3,3	8,1	8,1	15,8	15,8	27,8	71,0	138,6		
Approved bending moments (Screw 5.8)	appr. M	[Nm]	-	4,3	10,9	10,9	21,1	21,1	37,1	94,9	185,1		
Approved bending moments (Screw 8.8)	appr. M	[Nm]	-	6,9	17,1	17,1	33,7	34,3	60,0	152,0	296,6		
Spacing and edge distance													
Effective anchorage depth	h _{ef}	[mm]	25	30	30	40	30	40	50	65	80		
Characteristic spacing	s _{cr, N}	[mm]	75	90	90	120	90	120	150	195	240		
Characteristic edge distance	c _{cr, N}	[mm]	37,5	45	45	60	45	60	75	97,5	120		
Minimum spacing	s _{min}	[mm]	60	55	60	80	100	100	120	150	160		
Minimum edge distance	c _{min}	[mm]	95	95	95	95	115	135	165	200	260		
Minimum thickness of concrete slab	h _{min}	[mm]	100	100	100	100	120	120	130	160	200		
Installation parameters													
Drill hole diameter	d _o	[mm]	8	8	10	10	12	12	15	20	25		
Diameter of clearance hole in the fixture	d _f	[mm]	6	7	9	9	12	12	14	18	22		
Depth of drill hole	h _o	[mm]	25	30	30	40	30	40	50/80 ³⁾	65/80 ⁴⁾	80		
Installation torque	≤ T _{inst}	[Nm]	3	4	8	8	15	15	35	60	120		
Minimum screwing depth	L _{sd}	[mm]	6	7	9	9	10	11	13	18	22		
Maximum screwing depth	L _{th}	[mm]	10	13	13	20	12	15	18/45 ³⁾	23/38 ⁴⁾	34		

¹⁾ Valid only for statically indeterminate systems.

²⁾ Not part of assessment.

³⁾ E/ES M12x50 / E M12x80

⁴⁾ E M16x55 / E M16x80



Extract from Permissible Service Conditions of European Technical Assessment ETA-05/0116

Multiple use for non-structural applications. Total safety factor as per ETAG 001 included (γ_M and γ_P). The maximum load per fixing point for multiple use for non-structural applications may, depending on national regulations, are below the approved load of the anchor. The approved loads per fixing point are regulated for their respective countries in the ETAG 001, Part 6.

Loads and performance data	Drop-in Anchor E/ES		M6x25	M6x30	M8x25	M8x30	M8x40	M10x25	M10x30	M10x40	M12x25	M12x50	M16x65	cracked and non-cracked concrete	
Approved loads (C12/15 and C16/20)	appr. F	[kN]	1,2	-	1,2	-	-	1,7	-	-	1,7	-	-		
Approved loads (C20/25 to C50/60)	appr. F	[kN]	1,7	1,2	1,9	1,7	2,0	2,1	2,0	2,0	2,1	2,4	6,3		
Approved bending moments (Screw 4.6)	appr. M	[Nm]	2,6	2,6	6,4	6,4	6,4	12,8	12,8	12,8	22,2	22,2	56,9		
Approved bending moments (Screw 5.6)	appr. M	[Nm]	3,3	3,3	8,1	8,1	8,1	15,8	15,8	15,8	27,8	27,8	71,0		
Approved bending moments (Screw 5.8)	appr. M	[Nm]	4,3	4,3	10,9	10,9	10,9	21,1	21,1	21,1	37,1	37,1	94,9		
Approved bending moments (Screw 8.8)	appr. M	[Nm]	6,9	6,9	17,1	17,1	17,1	34,3	33,7	34,3	60,0	60,0	152,0		
Spacing and edge distance															
Effective anchorage depth	h _{ef}	[mm]	25	30	25	30	40	25	30	40	25	50	65		
Characteristic spacing	s _{cr}	[mm]	75	130	75	180	210	75	230	170	75	170	400		
Characteristic edge distance	c _{cr}	[mm]	38	65	38	90	105	38	115	85	38	85	200		
Minimum spacing ¹⁾	s _{min}	[mm]	30	55	50	60	80	60	100	100	100	120	150		
Minimum edge distance ¹⁾	c _{min}	[mm]	60	95	100	95	95	100	115	135	110	165	200		
Standard/Minimum thickness of concrete slab	h _{min 2} / h _{min 1}	[mm]	100/80	100	100/80	100	100	100/80	120	120	100/80	130	160		
Installation parameters															
Drill hole diameter	d _o	[mm]	8	8	10	10	10	12	12	12	15	15	20		
Diameter of clearance hole in the fixture	d _f	[mm]	7	7	9	9	9	12	12	12	14	14	18		
Depth of drill hole	h _o	[mm]	25	30	25	30	40	25	30	40	25	50	65		
Installation torque	≤ T _{inst}	[Nm]	4	4	8	8	8	15	15	15	35	35	60		
Minimum screwing depth ¹⁾	L _{sd}	[mm]	6	7	8	9	9	10	10	11	12	13	18		
Maximum screwing depth ¹⁾	L _{th}	[mm]	12	13	12	13	20	12	12	15	12	18	23		
Loads under fire exposure (C20/25 to C50/60)															
(for screw ≥ 4.8)	Approved loads R30	appr. F	[kN]	0,4	0,4	0,6	0,9	1,1	0,6	0,9	1,5	0,6	1,5	4,0	
	Approved loads R60	appr. F	[kN]	0,35	0,35	0,6	0,9	0,9	0,6	0,9	1,5	0,6	1,5	4,0	
	Approved loads R90	appr. F	[kN]	0,3	0,3	0,6	0,6	0,6	0,6	0,9	1,1	0,6	1,5	3,0	
	Approved loads R120	appr. F	[kN]	0,25	0,3	0,5	0,5	0,5	0,7	0,9	0,5	1,2	2,4		
(for screw ≥ 5.6)	Approved loads R30	appr. F	[kN]	0,4	0,8	0,6	0,9	1,5	0,6	0,9	1,5	0,6	1,5	4,0	
	Approved loads R60	appr. F	[kN]	0,35	0,8	0,6	0,9	1,5	0,6	0,9	1,5	0,6	1,5	4,0	
	Approved loads R90	appr. F	[kN]	0,3	0,4	0,6	0,9	0,9	0,6	0,9	1,5	0,6	1,5	3,7	
	Approved loads R120	appr. F	[kN]	0,25	0,3	0,5	0,5	0,5	0,7	1,0	0,5	1,2	2,4		
Characteristic spacing	s _{cr, fi}	[mm]	100	130	100	180	210	100	170	170	100	200	400		
Characteristic edge distance	c _{cr, fi}	[mm]	50	65	50	90	105	50	85	85	50	100	200		

For anchor designing, an easy to operate CD-ROM is available on request or can be downloaded at www.mkt.de.

¹⁾Data for minimum thickness of concrete see ETA-05/0116



Extract from Permissible Service Conditions of European Technical Assessment ETA-05/0116

Multiple use for non-structural applications. Total safety factor as per ETAG 001 included (γ_M and γ_P). The maximum load per fixing point for multiple use for non-structural applications may, depending on national regulations, are below the approved load of the anchor. The approved loads per fixing point are regulated for their respective countries in the ETAG 001, Part 6.

Loads and performance data	Drop-in Anchor ES	M6 x 25	M8 x 25	M10 x 25	M12 x 25	
Precast pre-stressed hollow core slabs C30/37 to C50/60						
Flange thickness	$d_b \geq$	[mm]	35 (30 ¹⁾)			
Approved loads	$F_{appr.}$	[kN]	1,7	1,9	2,1	2,1
Approved bending moments (Steel 4.6)	$appr. M$	[Nm]	2,6	6,4	12,8	22,2
Approved bending moments (Steel 4.8)	$appr. M$	[Nm]	3,5	8,6	17,1	29,7
Approved bending moments (Steel 5.6)	$appr. M$	[Nm]	3,3	8,1	15,8	27,8
Approved bending moments (Steel 5.8)	$appr. M$	[Nm]	4,3	10,9	21,1	37,1
Approved bending moments (Steel 8.8)	$appr. M$	[Nm]	6,9	17,1	34,3	60,0
Spacing and edge distance						
Spacing distance	$S_{cr} = S_{min}$	[mm]	200			
Edge distance	$C_{cr} = C_{min}$	[mm]	150			
Installation parameters						
Drill hole diameter	d_o	[mm]	8	10	12	15
Diameter of clearance hole in the fixture	d_f	[mm]	7	9	12	14
Depth of drill hole	$h_o \geq$	[mm]	25	25	25	25
Installation torque	$T_{inst} \leq$	[Nm]	4	8	15	35

¹⁾Drill hole must not cut hollow core

Admissible anchor positions in precast pre-stressed hollow core slabs

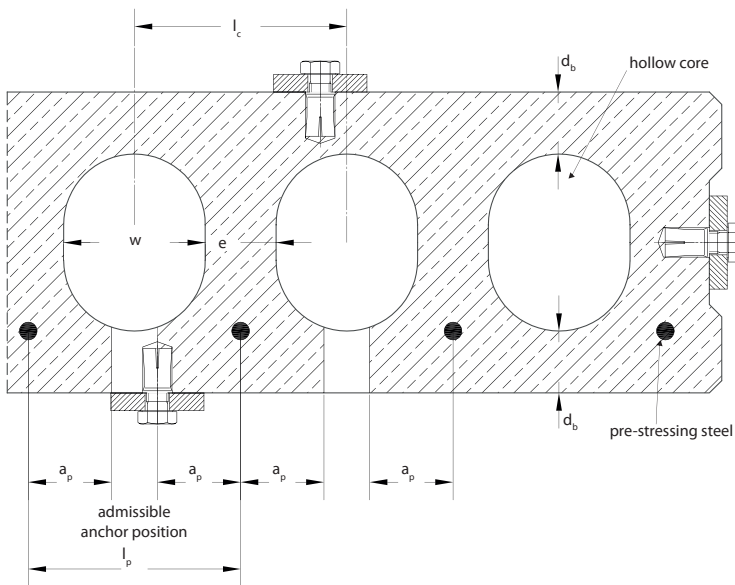

Minimum spacing and edge distance in precast pre-stressed hollow core slabs

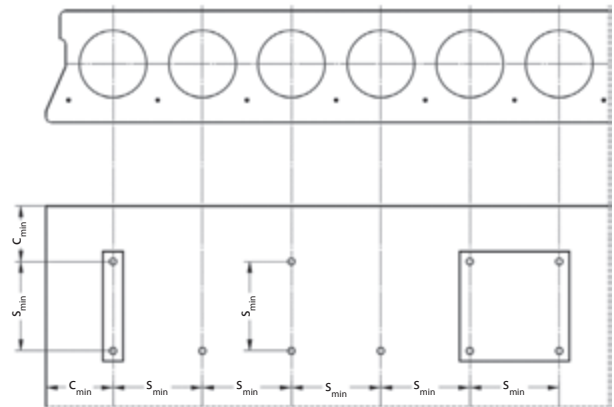

$w / e \leq 4,2$

w hollow core width

e web thickness

Minimum edge distance $C_{min} \geq 150$ mm

Minimum spacing $S_{min} \geq 200$ mm

Core distance $l_c \geq 100$ mm

Pre-stressing steel distance $l_p \geq 100$ mm

Distance between anchor position and pre-stressing steel $a_p \geq 50$ mm

Installation

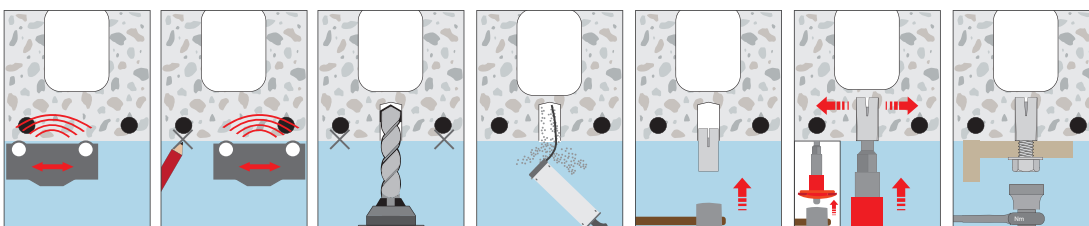

Drop-in Anchor ED

Steel, zinc plated



Description

The Drop-in Anchor ED is designed for temporary mounting or fastenings of machines that are to be moved at a later time. The ED M12 D version with reinforced anchor shell is especially designed for the fastening of core drilling machines.

Applications

Fastening of concrete processing tools such as core-drills and concrete saws.

Base Material: concrete C20/25 - C 50/60



Drop-in Anchor ED



→ Steel, zinc plated

→ Suitable for diamond drilling equipment

Description	Ref. No.	Drill hole Ø x depth mm	Thread Ø x length mm	Package content pcs.	Weight per package kg
ED M 12 x 50	05301101	15 x 50	M12 x 18	50	2,39
ED M 12 x 50 D	05317101	16 x 50	M12 x 18	50	2,81
ED M 16 x 65	05501101	20 x 65	M16 x 23	25	2,72

Standard Setting Tool

for Drop-in Anchor ED



Description	Ref. No.
E-SW 12 x 50	09300150
E-SW 16 x 65	09500150

Recommended loads for Drop-in Anchor ED.

Total safety factor as per ETAG 001 included (γ_M and γ_F).

Loads and performance data	Drop-in Anchor ED				
		M 12x50	M 12x50 D	M 16x65	
non-cracked concrete					
Recommen. loads, tension (Screw 5.6 to 8.8)	C20/25 rec. N	[kN]	7,1	7,1	10,5
Recommen. loads, shear (Screw 5.6)	\geq C20/25 rec. V	[kN]	9,0	9,0	16,8
Recommen. loads, shear (Screw 5.8/8.8)	\geq C20/25 rec. V	[kN]	12,0	12,0	18,0
Recommen. bending moments (Screw 5.6)	rec. M	[Nm]	27,8	27,8	71,0
Recommen. bending moments (Screw 5.8)	rec. M	[Nm]	37,1	37,1	94,9
Recommen. bending moments (Screw 8.8)	rec. M	[Nm]	60,0	60,0	152,0
Spacing and edge distance					
Effective anchorage depth	h_{ef}	[mm]	50	50	65
Characteristic spacing	$s_{cr, N}$	[mm]	150	150	195
Characteristic edge distance	$c_{cr, N}$	[mm]	75	75	97,5
Minimum spacing	s_{min}	[mm]	120	120	150
Minimum edge distance	c_{min}	[mm]	165	165	200
Minimum thickness of concrete slab	h_{min}	[mm]	130	130	160
Installation parameters					
Drill hole diameter	d_o	[mm]	15	16	20
Diameter of clearance hole in the fixture	d_f	[mm]	14	14	18
Depth of drill hole	h_o	[mm]	50	50	65
Installation torque	T_{inst}	[Nm]	35	35	60
Minimum screwing depth	L_{sd}	[mm]	13	13	18
Maximum screwing depth	L_{th}	[mm]	18	18	23

Installation

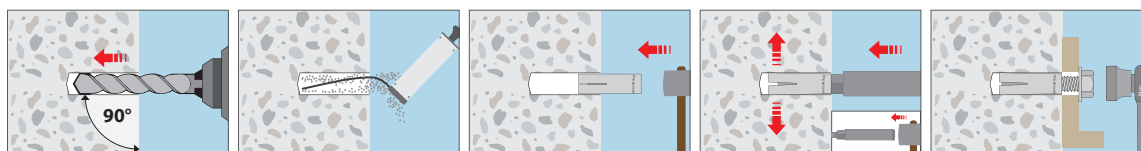

Drop-in Anchor ED-DW 15

Steel, zinc plated



Description

Drop-in Anchor with DYWIDAG® internal thread¹⁾ DW 15 for post installed threadbar (DYWIDAG®) connections. Suitable for concrete C12/15-C50/60 or hard natural stone. Safe installation if debris makes the thread impassible. The Drop-in Anchor does not protrude out of the concrete after removing the threadbar.

Applications

Multi-functional Anchor for concrete formwork. Cost efficient, quick fixing into existing concrete. Ideal for fixing one-sided formwork or temporary guardrails.



Base Material: concrete C12/15 - C 50/60
or hard natural stone

Drop-in Anchor ED-DW 15



- Steel, zinc plated
- For fixing threadbars in formwork

Standard Setting Tool

for Drop-in Anchor ED-DW 15



Description	Ref. No.	Drill hole Ø x depth mm	Thread Ø x length mm	Package content pcs.	Weight per package kg
ED-DW 15 x 80	05950101	22 x 80	DW 15 x 35	25	3,76

Description	Ref. No.
E-SW 16 x 80 / DW-15 x 80	9505150

Recommended loads for ED-DW 15.

Total safety factor as per ETAG 001 included (γ_M and γ_p).

Loads and performance data	Applied load angle	0°	15°	30°	45°	60°	75°	90°	
									non-cracked concrete
Recommended loads	C12/15	rec. F [kN]	17,3	16,9	16,8	17,4	18,7	20,6	22,6
	≥ C20/25	rec. F [kN]	19,3	18,7	18,3	18,6	19,5	21,1	22,6

Spacing and edge distance

Effective anchorage depth	h_{ef}	[mm]	80
Minimum spacing	s_{min}	[mm]	600
Minimum edge distance	c_{min}	[mm]	300
Minimum thickness of concrete slab	h_{min}	[mm]	160

Installation parameters

Drill hole diameter	d_o	[mm]	22
Depth of drill hole	h_o	[mm]	80
Length of thread	L_{th}	[mm]	35
Stab/Screw DW15 minimum installation depth		[mm]	28

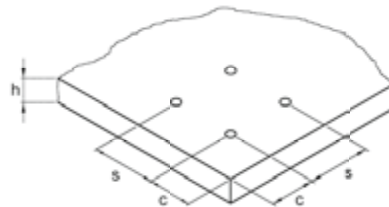
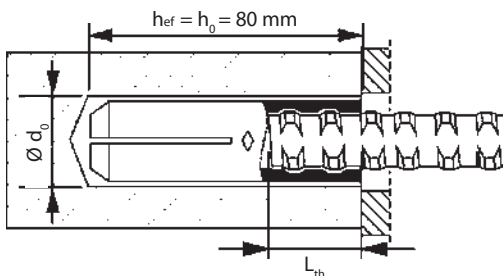
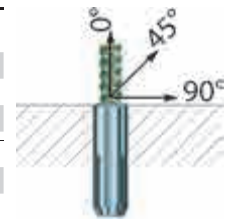

Installation

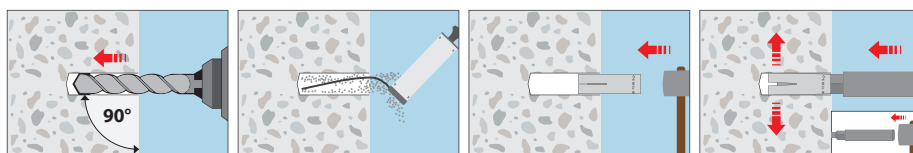

¹⁾ DYWIDAG® internal thread (DYWIDAG® is a registered trademark of Walter Bau AG)

Drop-in Anchor E/ES A4 / E HCR

Stainless steel A4/316 / High corrosion resistant steel 1.4529 (HCR)



Drop-in Anchor E A4



Drop-in Anchor ES A4

Range of loading: 1,2 kN - 30,4 kN

Range of concrete quality: C20/25 - C50/60



Description

The Drop-in Anchor E/ES A4 / E HCR is approved as single anchor in uncracked concrete as well as for redundant fastening use for non-structural applications in cracked and uncracked concrete.

The Drop-in Anchor E/ES A4 / E HCR is placed into the drill hole in pre-setting installation and expanded reliably by means of a manual or hammer drill setting tool. Using a detachable setting tool with a stop drill bit (ASW) allows for quick and efficient, high volume installations. Using the marking setting tool produces a visible marking on the anchor sleeve which confirms the correct installation. The use of coated screws is necessary in order to be able to remove the fixture.

Advantages

- Approved for use as multiple fixing in cracked and uncracked concrete
- Approved for use as single fixing in uncracked concrete
- Quick, rational and efficient installation due to the detachable setting tool with a stop drill bit (ASW)
- Simple visual inspection with marking tool
- Many possible applications due to the use of standard metric screws and threaded rods
- FM approval for the installation of sprinkler systems (M10-M20)
- Suitable for the installation of sprinkler systems according to the requirements of damage prevention VDS, GmbH (M8-M16)
- Fire resistance tested in concrete C20/25 to C50/60

Applications

Attaching suspended ceilings, ventilation and sprinkler systems, structural steel, brackets, threaded rods.

Drop-in Anchor E A4



→ Stainless steel A4/316

→ Approved for concrete

Description	Ref. No.	Drill hole Ø x depth mm	Thread Ø x length mm	Package content pcs.	Weight per package kg
E M 5 x 25 A4 ²⁾	05000501	8 x 25	M5 x 10	100	0,75
E M 6 x 30 A4	05005501	8 x 30	M6 x 13	100	0,83
E M 8 x 30 A4	05100501	10 x 30	M8 x 13	100	1,16
E M 8 x 40 A4	05105501	10 x 40	M8 x 20	100	1,49
E M 10 x 40 A4	05200501	12 x 40	M10 x 15	50	1,08
E M 12 x 50 A4	05300501	15 x 50	M12 x 18	50	2,19
E M 16 x 65 A4	05500501	20 x 65	M16 x 23	25	2,57
E M 20 x 80 A4	05600501	25 x 80	M20 x 34	25	4,63

Drop-in Anchor ES A4



→ Stainless steel A4, Approved for concrete

→ Lipped Drop-in for installations in a bottomless hole

Description	Ref. No.	Drill hole Ø x depth mm	Thread Ø x length mm	Package content pcs.	Weight per package kg
ES M 8 x 30 A4	05150501	10 x 30	M8 x 13	100	1,15
ES M 10 x 40 A4	05250501	12 x 40	M10 x 15	50	1,10
ES M 12 x 50 A4	05350501	15 x 50	M12 x 18	50	2,15

¹⁾Only for use in non-structural applications

²⁾Applies only to anchorage depths $h_{ef} \geq 30$ mm

Safety Setting Tool

For Drop-in Anchor E and ES
With hand guard



Description	Ref. No.	Weight per piece kg
E-MSH 8 x 30	09100801	0,42
E-MSH 8 x 40	09105801	0,38
E-MSH 10 x 30	09205801	0,50
E-MSH 10 x 40	09200801	0,45
E-MSH 12 x 50	09300801	0,47
E-MSH 12 x 80	09305801	0,51
E-MSH 16 x 65	09500801	0,50
E-MSH 16 x 80	09505801	0,55
E-MSH 20 x 80	09600801	0,62

Standard Setting Tool

For Drop-in Anchor E and ES



Description	Ref. No.	Weight per piece kg
E-SW 5 x 25	09000150	0,08
E-SW 6 x 30	09005150	0,09
E-SW 8 x 30	09100150	0,14
E-SW 8 x 40	09105150	0,14
E-SW 10 x 30	09205150	0,15
E-SW 10 x 40	09200150	0,15
E-SW 12 x 50	09300150	0,25
E-SW 12 x 80	09305150	0,22
E-SW 16 x 65	09500150	0,41
E-SW 16 x 80/DW 15	09505150	0,42
E-SW 20 x 80	09600150	0,68

Plug-on setting tool with stop drill bit

For Drop-in Anchor E and ES.



Description	Ref. No.	For Drop-in Anchor	Suitable stop drill bit	Package content pcs.	Weight per piece kg
E-ASW 6 x 30	09098101	E/ES M 6 x 30	BB 8 x 30	1	0,20
E-ASW 8 x 30	09198101	E/ES M 8 x 30	BB 10 x 30	1	0,20
E-ASW 8 x 40	09199101	E/ES M 8 x 40	BB 10 x 40	1	0,23
E-ASW 10 x 30	09298101	E/ES M 10 x 30	BB 12 x 30	1	0,21
E-ASW 10 x 40	09299101	E/ES M 10 x 40	BB 12 x 40	1	0,24

Stop drill bit

For Drop-in Anchor E and ES.



Description	Ref. No.	Drill hole Ø x depth [mm]	For Drop-in Anchor	Suitable for plug-on setting tool	Package content pcs.	Weight per piece kg
BB 8 x 30	50031501	8 x 30	E/ES M 6 x 30	E-ASW 6 x 30	1	0,11
BB 10 x 30	50041501	10 x 30	E/ES M 8 x 30	E-ASW 8 x 30	1	0,11
BB 10 x 40	50042001	10 x 40	E/ES M 8 x 40	E-ASW 8 x 40	1	0,12
BB 12 x 30	50051501	12 x 30	E/ES M 10 x 30	E-ASW 10 x 30	1	0,12
BB 12 x 40	50052001	12 x 40	E/ES M 10 x 40	E-ASW 10 x 40	1	0,12
BB 15 x 50	50072501	15 x 50	E/ES M 12 x 50	-	1	0,17

SDS Setting Tool

For Drop-in Anchor E and ES.
With SDS plus connection.



Description	Ref. No.	Weight per piece kg
E-SW 8 x 30 SDS	09190101	0,07
E-SW 8 x 40 SDS	09195101	0,07
E-SW 10 x 30 SDS	09288101	0,08
E-SW 10 x 40 SDS	09290101	0,08
E-SW 12 x 50 SDS	09390101	0,10

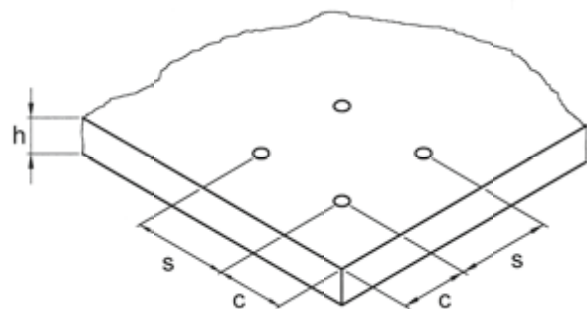
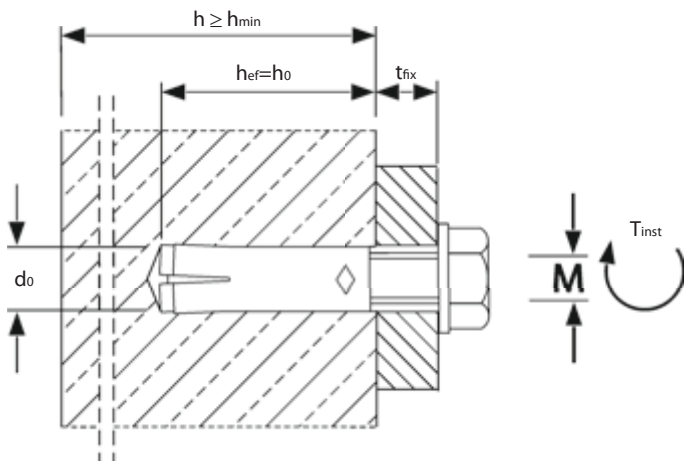

Installation

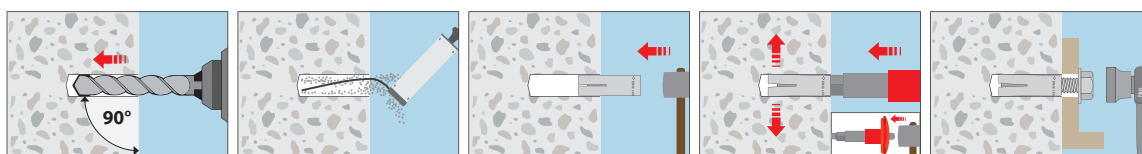



Extract from Permissible Service Conditions of European Technical Assessment ETA-02/0020

Approved loads for single anchor without influence of spacing and edge distance. Total safety factor as per ETAG 001 included (γ_M and γ_P). Load capacities under fire exposure see page 167.

Loads and performance data	Drop-in Anchor E A4 / HCR		M5x25 ¹⁾	M6x30 ¹⁾	M8x30 ¹⁾	M8x40	M10x40	M12x50 M12x80	M16x65 M16x80	M20x80		
			non-cracked concrete									
Mean ultimate loads, tension	C25/30	Num	[kN]	8,0	12,2	14,2	16,1	19,8	27,7	41,0	62,7	
Mean ultimate loads, shear	C25/30	V _{um}	[kN]	5,7	8,5	14,1	14,8	20,3	37,3	64,9	94,6	
Approved loads, tension	C20/25	appr. N	[kN]	1,6	3,9	3,9	4,3	6,1	8,5	12,6	17,2	
				C25/30	1,7	4,2	4,3	4,7	6,7	9,3	13,8	18,9
				C30/37	1,9	4,4	4,8	5,2	7,4	10,4	15,3	21,0
				C40/50	2,2	4,8	5,6	6,0	8,6	12,0	17,7	24,2
Approved loads, shear	≥ C20/25	appr. V	[kN]	2,5	5,1	6,1	6,6	9,4	13,2	19,5	26,6	
				2,3	3,2	4,9	4,9	6,1	11,5	19,2	30,4	
Approved bending moments (Screw A4-70)		appr. M	[Nm]	-	5,0	11,9	11,9	23,8	42,1	106,7	207,9	
Spacing and edge distance												
Effective anchorage depth		h _{ef}	[mm]	25	30	30	40	40	50	65	80	
Characteristic spacing		s _{cr,N}	[mm]	75	90	90	120	120	150	195	240	
Characteristic edge distance		c _{cr,N}	[mm]	37,5	45	45	60	60	75	97,5	120	
Minimum spacing		s _{min}	[mm]	60	50	60	80	100	120	150	160	
Minimum edge distance		c _{min}	[mm]	95	80	95	95	135	165	200	260	
Minimum thickness of concrete slab		h _{min}	[mm]	100	100	100	100	130	140	160	250	
Installation parameters												
Drill hole diameter		d _o	[mm]	8	8	10	10	12	15	20	25	
Diameter of clearance hole in the fixture		d _f	[mm]	6	7	9	9	12	14	18	22	
Depth of drill hole		h _o	[mm]	25	30	30	40	40	50/80 ²⁾	65/80 ³⁾	80	
Installation torque		≤ T _{inst}	[Nm]	3	4	8	8	15	35	60	120	
Minimum screwing depth		L _{sd}	[mm]	6	7	9	9	11	13	18	22	
Maximum screwing depth		L _{th}	[mm]	10	13	13	20	15	18	23	34	

¹⁾Valid only for statically indeterminate systems. Size M 5 not part of assessment.

²⁾E/ES M 12x50/E M 12x80

³⁾E M 16x65/E M 16x80

For anchor designing, an easy to operate CD-ROM is available on request or can be downloaded at www.mkt.de.



Extract from Permissible Service Conditions of European Technical Assessment ETA-05/0116

Multiple use for non-structural applications. Total safety factor as per ETAG 001 included (γ_M and γ_P). The maximum load per fixing point for multiple use for non-structural applications may, depending on national regulations, be below the approved load of the anchor. The approved loads per fixing point are regulated for their respective countries in the ETAG 001, Part 6

Loads and performance data	Drop-in Anchor E A4 / HCR		M6x30	M8x30	M8x40	M10x40	M12x50	M16x65	
			cracked and non-cracked concrete						
Approved loads (C20/25 to C50/60)		appr. F	[kN]	1,2	1,7	2,0	2,0	2,4	6,3
Approved bending moments (A4-70)		appr. M	[Nm]	5,0	11,9	11,9	23,8	42,1	106,7
Spacing and edge distance									
Effective anchorage depth		h _{ef}	[mm]	30	30	40	40	50	65
Characteristic spacing		s _{cr}	[mm]	130	180	210	170	170	400
Characteristic edge distance		c _{cr}	[mm]	65	90	105	85	85	200
Minimum spacing		s _{min}	[mm]	50	60	80	100	120	150
Minimum edge distance		c _{min}	[mm]	80	95	95	135	165	200
Minimum thickness of concrete slab		h _{min}	[mm]	100	100	100	130	140	160
Installation parameters									
Drill hole diameter		d _o	[mm]	8	10	10	12	15	20
Diameter of clearance hole in the fixture		d _f	[mm]	7	9	9	12	14	18
Depth of drill hole		h _o	[mm]	30	30	40	40	50	65
Installation torque		≤ T _{inst}	[Nm]	4	8	8	15	35	60
Minimum screwing depth		L _{sd}	[mm]	7	9	9	11	13	18
Maximum screwing depth		L _{th}	[mm]	13	13	20	15	18	23
Loads under fire exposure									
Approved loads R30		appr. F	[kN]	0,8	0,9	1,5	1,5	1,5	4,0
Approved loads R60		appr. F	[kN]	0,8	0,9	1,5	1,5	1,5	4,0
Approved loads R90		appr. F	[kN]	0,4	0,9	0,9	1,5	1,5	3,7
Approved loads R120		appr. F	[kN]	0,3	0,5	0,5	1,0	1,2	2,4
Characteristic spacing		s _{cr,fi}	[mm]	130	180	210	170	200	400
Characteristic edge distance		c _{cr,fi}	[mm]	65	90	105	85	100	200
Minimum spacing		s _{min}	[mm]	50	60	80	100	120	150
Minimum edge distance		c _{min}	[mm]	80	95	95	135	165	200

For anchor designing, an easy to operate CD-ROM is available on request or can be downloaded at www.mkt.de.

Hollow Core Anchor Easy

Steel, zinc plated



Range of loading: 0,7 kN - 4,3 kN
Concrete quality: ≥ C45/55 respectively B55;
 pre-stressed hollow concrete slabs



Description

The Hollow-Core Anchor Easy is a one-piece unit, specially designed for anchoring in pre-stressed hollow concrete slabs. Tightening the screw or nut pulls the expansion cone inside the anchor sleeve which keys into in the cavity or provides strong expansion in solid concrete. The approval Z-21.1-1785 allows the anchor to be installed even if the drill hole does not hit the cavity.

Applications

Suspension of ventilation, sprinkler system, false ceilings, brackets with threaded studs or screws, ducts, anchoring prefabricated panels on hollow concrete floors/ceilings.

Advantages:

- Simple and flexible to use
- Even approved if the drill hole does not hit the cavity
- To be used with standard screws or threaded rods

Hollow Core Anchor Easy



- Steel, zinc plated
- For pre-stressed hollow concrete slabs

Description	Ref. No.	Drill hole Ø mm	Thread Ø mm	Package content pieces	Weight per package kg
Easy M 6	51005101	10	M 6	50	0,52
Easy M 8	51100101	12	M 8	50	0,72
Easy M 10	51200101	16	M 10	50	1,66
Easy M 12	51300101	18	M 12	25	1,08

Note on the used screws:

- The screws must have a sufficiently long thread in order to expand the anchor safely.
- Recommended screws to be used DIN 933 / DIN EN ISO 898
- The required screw length is determined by the „minimum length of screw“ (see table page 53) + the thickness of the fixture (t_{fix})
- screws M6 at least have the strength 8.8
M8 - M12 at least 5.8

Note to the threaded stud and nuts used:

- The minimum required stud length is determined by the „minimum length of stud“ (see table page 53) + the thickness of the fixture (t_{fix}), if exist
- M6 threaded stud must have at least the strength of 8.8, M6 nut must have strength class 8
- M8-M12 threaded stud must have at least the strength of 5.8, M8-M12 nut must have strength class 5

Installation

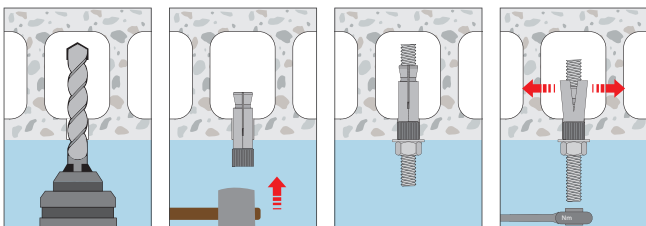



Extract from Permissible Service Conditions of Z-21.1-1785

Approved loads for single anchor without influence of spacing and edge distance.

Total safety factor as per ETAG 001 included (γ_M and γ_P). Load capacities under fire exposure see page 167.

Loads and performance data	Easy	M 6				M 8				M 10				M 12				
		Precast pre-stressed hollow concrete slabs \geq C45/55																
Flange thickness	d_u	[mm]	\geq 25	30	40	50	25	30	40	50	25	30	40	50	25	30	40	50
Mean ultimate loads, tension	C45/55 N_{um}	[kN]	6,6	8,6	8,6	8,6	7,0	9,3	11,7	11,7	9,1	12,0	18,4	18,4	9,4	12,3	19,0	22,7
Mean ultimate loads, shear	C45/55 V_{um}	[kN]	6,9	8,1	8,1	8,1	7,3	8,7	9,2	9,2	8,0	9,4	12,2	14,5	8,3	9,8	12,7	15,5
Single anchor																		
Approved loads ¹⁾ (for $c \geq c_{cr}$)	$F^{(1)}$	[kN]	0,7	0,9	2,0	2,9	0,7	0,9	2,0	3,6	0,9	1,2	3,0	3,6	1,0	1,2	3,0	4,3
Edge distance	c_{cr}	[mm]	150				150				150				150			
Approved loads ¹⁾ (for c_{min})	$F^{(1)}$	[kN]	0,35	0,8	1,8	2,4	0,35	0,8	1,8	3,0	0,8	1,0	2,7	3,0	0,8	1,0	2,7	3,6
Minimum edge distance	c_{min}	[mm]	100				100				100				100			
Spacing	s_{cr}	[mm]	300				300				300				300			
Pair of anchors²⁾																		
Approved loads ¹⁾ (for $c \geq c_{cr}$)	$F^{(1)}$	[kN]	0,7	1,4	2,6	3,9	0,7	1,4	2,6	4,8	1,1	2,0	4,8	4,8	1,2	2,0	4,8	5,7
Minimum spacing	s_{min}	[mm]	70	80	100	100	70	80	100	100	70	80	100	100	70	80	100	100
Edge distance	c_{cr}	[mm]	150				150				150				150			
Approved loads ¹⁾ (for c_{min})	$F^{(1)}$	[kN]	0,35	1,25	2,35	3,2	0,35	1,25	2,35	4,0	0,9	1,8	4,3	4,3	1,0	1,8	4,3	4,8
Minimum spacing	s_{min}	[mm]	70	80	100	100	70	80	100	100	70	80	100	100	70	80	100	100
Minimum edge distance	c_{min}	[mm]	100				100				100				100			
Approved bending moments																		
Stud / Screw, steel 5.8		[Nm]	-				10,7				21,4				37,4			
Stud / Screw, steel 8.8		[Nm]	4,4				17,1				34,2				59,8			
Installation parameters																		
Length of sleeve (without cone)	L	[mm]	30				35				40				45			
Minimum length of screw	min l_s	[mm]	42 + t_{fix}				47 + t_{fix}				55 + t_{fix}				61 + t_{fix}			
Minimum length of stud	min l_b	[mm]	47 + t_{fix}				53 + t_{fix}				63 + t_{fix}				71 + t_{fix}			
Minimum strength of stud / screw			8.8				5.8				5.8				5.8			
Drill hole diameter	d_o	[mm]	10				12				16				18			
Clearance hole in the fixture	d_f	[mm]	7				9				12				14			
Depth of drill hole	h_o	[mm]	50				55				60				70			
Installation torque	T_{inst}	[Nm]	10				20				30				40			

¹⁾For edge distance $c_{min} < c \leq c_{cr}$ can be determined by linear interpolation.

²⁾Approved loads valid for double anchorage. Recommended load of the most stressed anchor may not exceed the recommended load of a single anchor. On double anchorages with spacing $s_{min} < s < s_{cr}$ the recommended load may be determined by linear interpolation, assuming the limiting value $s = s_{cr}$ for the double anchorage exposed to tension is twice the recommended load of a single anchor.

Condition: $b_H < 4.2 \times b_{St}$

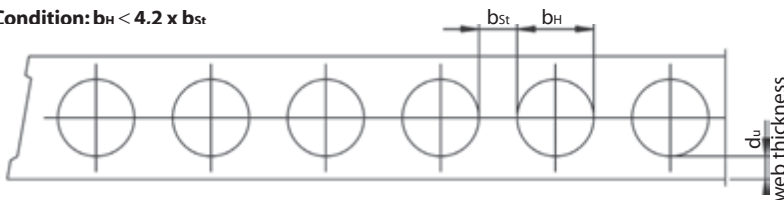

Arrangement of the anchors

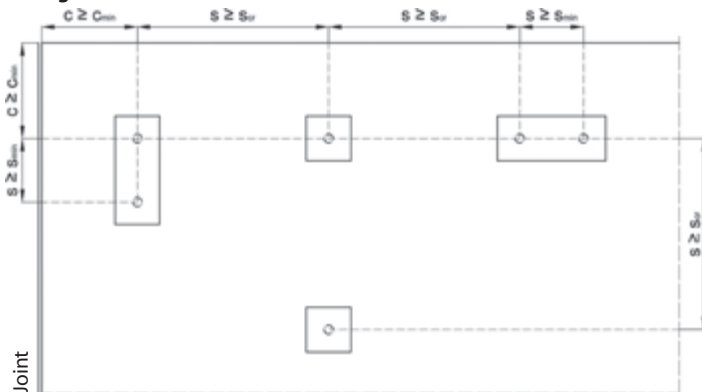

Installation with a threaded stud

Hollow

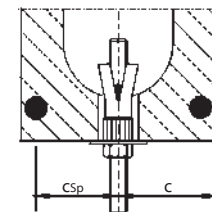

Installation with a screw

Solid

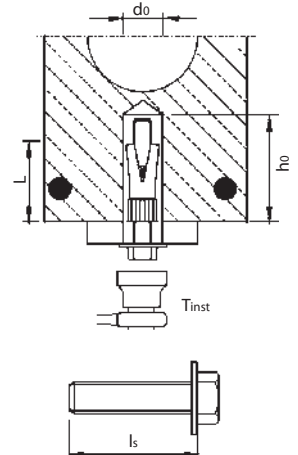
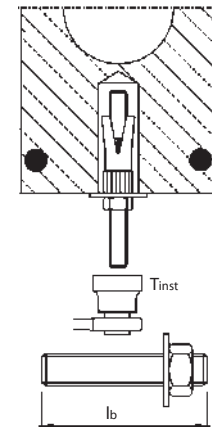

- t_{fix} = Fixture thickness
- d_u = Flange thickness
- b_H = Width of hollow
- b_{St} = Web width
- c_{sp} = Spacing to tension wire
- c = Edge distance

Mechanical Heavy Duty Anchors

Highload Anchor SZ

Steel, zinc plated



Highload Anchor SZ-S



Highload Anchor SZ-B



Highload Anchor SZ-SK



Range of loading: 2,4 kN - 96,8 kN

Range of concrete quality: C20/25 - C50/60

Description

The ETA (Option 1) approved Highload Anchor SZ is a high-performance through fastening Anchor System with three part expansion sleeve. This allows for smaller spacings and edge distances with high loads. The plastic compression ring ensures the clamping of the mounted piece to the work surface. Three different models of the Highload Anchor SZ are available: Screw/washer SZ-S, Bolthead SZ-B and for flush surface mounting SZ-SK. All models have been shock-tested by the federal office for population protection in Bern/Switzerland.



Advantages

- High tension and shear loads
- Screw/washer (SZ-B) model and flat head (SZ-SK) model for finished surfaces
- Can be dismantled with a flush surface result (only the cone and expansion sleeve remain in the drill-hole)
- Smaller spacings and edge distances
- ICC Evaluation Service listing, USA
- Fire protection approved
- Approved to use under seismic action according to the performance category C1+C2 (M8-M24)

Applications

Medium to highload anchoring in cracked and non-cracked concrete, e.g. trusses, railings, machines, scaffolding and consoles.

Highload Anchor SZ

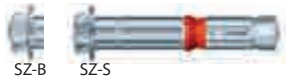

- Steel, zinc plated
- ETA approval for cracked and non-cracked concrete

Description	Type SZ-S Ref. No.	Type SZ-B Ref. No.	Drill hole Ø x depth mm	Drill hole depth through fixture mm	Setting depth mm	Anchor length		Seismic C1 / C2	Fixture thickness t _{fix} mm	Thread	Pkg. cont. pcs.	Weight per pkg. kg
						Typ S mm	Typ B mm					
SZ 10-0	14005301	16005301	10x65	65	60	65	67	- / -	0	M 6	100	3,25
SZ 10-10	14010301	16010301	10x65	75	60	75	77	- / -	10	M 6	50	1,94
SZ 10-30	14025301	16025301	10x65	95	60	95	97	- / -	30	M 6	50	2,47
SZ 10-50	14030301	16030301	10x65	115	60	115	117	- / -	50	M 6	50	2,94
SZ 10-100	-	16045301	10x65	165	60	-	167	- / -	100	M 6	25	2,05
SZ 12-0	14105301	16105301	12x80	80	70	75	80	✓ / ✓	0	M 8	50	2,93
SZ 12-10	14110301	16110301	12x80	90	70	85	90	✓ / ✓	10	M 8	50	3,31
SZ 12-30	14125301	16125301	12x80	110	70	105	110	✓ / ✓	30	M 8	50	4,10
SZ 12-50	14130301	16130301	12x80	130	70	125	130	✓ / ✓	50	M 8	25	2,47
SZ 12-100	-	16145301	12x80	180	70	-	180	✓ / ✓	100	M 8	25	3,22
SZ 15-0	14205301	16205301	15x95	95	85	91	96	✓ / ✓	0	M 10	25	2,85
SZ 15-15	14215301	16215301	15x95	110	85	110	111	✓ / ✓	15	M 10	25	3,31
SZ 15-25	14220301	16220301	15x95	120	85	116	121	✓ / ✓	25	M 10	25	3,59
SZ 15-45	14225301	16225301	15x95	140	85	136	141	✓ / ✓	45	M 10	25	4,20
SZ 15-95	14240301	16240301	15x95	190	85	186	191	✓ / ✓	95	M 10	25	5,60
SZ 18-0	14305301	16305301	18x105	105	95	107	112	✓ / ✓	0	M 12	20	3,84
SZ 18-10	14310301	16310301	18x105	115	95	117	122	✓ / ✓	10	M 12	20	4,18
SZ 18-20	14315301	16315301	18x105	125	95	127	132	✓ / ✓	20	M 12	20	4,53
SZ 18-40	14325301	16325301	18x105	145	95	147	152	✓ / ✓	40	M 12	20	5,21
SZ 18-70	14335301	16335301	18x105	175	95	177	182	✓ / ✓	70	M 12	20	6,26
SZ 18-100	-	16340301	18x105	205	95	-	212	✓ / ✓	100	M 12	10	3,55
SZ 24-0	14505301	16505301	24x130	130	120	130	137	✓ / ✓	0	M 16	10	4,11
SZ 24-20	14515301	16515301	24x130	150	120	150	157	✓ / ✓	20	M 16	10	4,71
SZ 24-50	14525301	16525301	24x130	180	120	180	187	✓ / ✓	50	M 16	10	5,58
SZ 24-100	-	16530301	24x130	230	120	-	237	✓ / ✓	100	M 16	5	3,49
SZ 24-0 L	14555301	16555301	24x145	145	135	150	152	✓ / ✓	0	M 16	10	4,70
SZ 24-30 L	14565301	16565301	24x145	175	135	180	182	✓ / ✓	30	M 16	10	5,57
SZ 24-50 L	14575301	16575301	24x145	195	135	200	202	✓ / ✓	50	M 16	10	6,20
SZ 28-10	14610301	16610301	28x160	170	150	172	181	✓ / ✓	10	M 20	10	7,76
SZ 28-30	14615301	16615301	28x160	190	150	192	201	✓ / ✓	30	M 20	5	4,35
SZ 28-60	14625301	16625301	28x160	220	150	222	231	✓ / ✓	60	M 20	5	5,02
SZ 28-100	14630301	16630301	28x160	260	150	262	271	✓ / ✓	100	M 20	5	5,88
SZ 32-10	14710301	16710301	32x180	190	170	212	217	✓ / ✓	10	M 24	5	5,93
SZ 32-30	14715301	16715301	32x180	210	170	232	237	✓ / ✓	30	M 24	5	6,41
SZ 32-60	14725301	16725301	32x180	240	170	262	267	✓ / ✓	60	M 24	5	7,21

NEW

Mechanical Heavy Duty Anchors

Highload Anchor SZ-SK



- Steel, zinc plated; with countersunk head
- ETA approval for cracked and non-cracked concrete

Description	Ref. No.	Drill hole Ø x depth mm	Drill hole depth through fixture mm	Setting depth mm	Anchor length mm	Seismic C1 / C2	Fixture thickness t _{fix} mm	Thread	Pkg. cont. pcs.	Weight per pkg. kg
SZ-SK 10-10	14011801	10 x 65	75	60	70	- / -	10	M 6	50	1,69
SZ-SK 10-25	14021801	10 x 65	90	60	85	- / -	25	M 6	50	2,30
SZ-SK 10-40	14031801	10 x 65	105	60	100	- / -	40	M 6	50	2,58
SZ-SK 12-10	14111801	12 x 80	90	70	80	✓ / ✓	10	M 8	50	3,01
SZ-SK 12-25	14121801	12 x 80	105	70	95	✓ / ✓	25	M 8	50	3,65
SZ-SK 12-50	14131801	12 x 80	130	70	120	✓ / ✓	50	M 8	25	2,33
SZ-SK 15-10	14211801	15 x 95	105	85	100	✓ / ✓	10	M 10	25	2,95
SZ-SK 15-25	14221801	15 x 95	120	85	110	✓ / ✓	25	M 10	25	3,29
SZ-SK 15-35	14226801	15 x 95	130	85	120	✓ / ✓	35	M 10	25	3,55
SZ-SK 15-50	14231801	15 x 95	145	85	135	✓ / ✓	50	M 10	25	3,96
SZ-SK 18-20	14316801	18 x 105	125	95	115	✓ / ✓	20	M 12	20	3,99
SZ-SK 18-40	14326801	18 x 105	145	95	135	✓ / ✓	40	M 12	20	4,62

Other lengths and special assemblies on demand.



Extract from Permissible Service Conditions of European Technical Assessment ETA-02/0030

Approved loads for single anchor without influence of spacing and edge distance.

Total safety factor as per ETAG 001 included (γ_M and γ_F). Load capacities under fire exposure see page 167.

Loads and performance data	Highload Anchor SZ		SZ 10 M 6	SZ 12 M 8	SZ 15 M 10	SZ 18 M 12	SZ 24 M 16	SZ 24L M 16	SZ 28 M 20	SZ 32 M 24
cracked concrete										
Mean ultimate loads, tension	C25/30 Num	[kN]	16,1	21,1	32,8	42,5	60,8	79,8	80,0	134,4
Mean ultimate loads, shear	C25/30 V _{um}	[kN]	18,0/19,0 ¹⁾	28,3/33,4 ¹⁾	42,0/58,6 ¹⁾	71,3/83,7 ¹⁾	106,0/143,7 ¹⁾	106,0/143,7 ¹⁾	151,4/198,5 ¹⁾	213,9/213,9 ¹⁾
Approved loads, tension	C20/25 appr. N	[kN]	2,4	5,7	7,6	12,3	17,1	21,1	24,0	31,5
	C25/30 appr. N	[kN]	2,6	6,3	8,3	13,4	18,8	23,2	26,2	34,5
	C30/37 appr. N	[kN]	2,9	7,0	9,3	14,9	20,9	25,7	29,1	38,3
	C40/50 appr. N	[kN]	3,4	8,1	10,8	17,3	24,2	29,9	33,9	44,5
	C50/60 appr. N	[kN]	3,7	8,9	11,8	19,0	26,6	32,8	37,1	48,8
non-cracked concrete										
Approved loads, tension	C20/25 appr. N	[kN]	7,6	9,5	14,4	17,2	24,0	29,7	33,6	44,2
	C25/30 appr. N	[kN]	7,6	10,4	15,8	18,8	26,3	32,5	36,8	48,4
	C30/37 appr. N	[kN]	7,6	11,6	17,5	20,9	29,3	36,1	40,9	53,7
	C40/50 appr. N	[kN]	7,6	13,5	20,3	24,3	34,0	41,9	47,5	62,5
	C50/60 appr. N	[kN]	7,6	13,8	21,9	26,7	37,3	45,9	52,0	68,4
cracked concrete										
Approved loads, shear SZ-S and SZ-SK	C20/25 appr. V	[kN]	10,3	15,9	20,5	24,5	34,3	42,3	47,9	63,0
	≥ C25/30 appr. V	[kN]	10,3	17,1	22,5	26,9	37,6	46,3	52,5	69,0
Approved loads, shear SZ-B	C20/25 appr. V	[kN]	9,1	14,3	20,5	24,5	34,3	42,3	47,9	63,0
	≥ C25/30 appr. V	[kN]	9,1	14,3	20,6	26,9	37,6	46,3	52,5	69,0
non-cracked concrete										
Approved loads, shear SZ-S and SZ-SK	C20/25 appr. V	[kN]	10,3	17,1	27,4	34,4	48,1	59,3	67,2	88,4
	≥ C25/30 appr. V	[kN]	10,3	17,1	27,4	37,7	52,7	65,0	73,6	96,8
Approved loads, shear SZ-B	C20/25 appr. V	[kN]	9,1	14,3	20,6	34,4	48,1	52,0	67,2	88,4
	≥ C25/30 appr. V	[kN]	9,1	14,3	20,6	36,0	52,0	52,0	69,7	96,8
cracked concrete / non-cracked concrete										
Approved bending moments	appr. M	[Nm]	6,9	17,1	34,3	60,0	152,0	152,0	296,6	513,1
Spacing and edge distance										
Effective anchorage depth	h _{ef}	[mm]	50	60	71	80	100	115	125	150
Characteristic spacing	s _{cr, N}	[mm]	150	180	213	240	300	345	375	450
Characteristic edge distance	c _{cr, N}	[mm]	75	90	106,5	120	150	172,5	187,5	225
cracked concrete concrete										
Minimum spacing / for edge distance c	s _{min} / c	[mm]	50/50	50/80	60/120	70/140	100/180	100/180	125/300	150/300
Minimum edge distance / for spacing s	c _{min} / s	[mm]	50/50	55/100	60/120	70/160	100/220	100/220	180/540	150/300
non-cracked concrete										
Minimum spacing / for edge distance c	s _{min} / c	[mm]	50/80	60/100	60/120	70/140	100/180	100/180	125/300	150/300
Minimum edge distance / for spacing s	c _{min} / s	[mm]	50/100	60/120	60/120	70/160	100/220	100/220	180/540	150/300
Minimum thickness of concrete slab	h _{min}	[mm]	100	120	140	160	200	230	250	300
Installation parameters										
Drill hole diameter	d ₀	[mm]	10	12	15	18	24	24	28	32
Diameter of clearance hole in the fixture	d _f	[mm]	12	14	17	20	26	26	31	35
Depth of drill hole	h ₁	[mm]	65	80	95	105	130	145	160	180
Installation torque	T _{inst}	[Nm]	15/10 ²⁾	30/25 ²⁾	50/55 ²⁾	80/70 ²⁾	160	160	280	280
Width across nut SZ (-S, -B)	SW	[mm]	10	13	17	19	24	24	30	36
Internal hexagon size SZ-SK	SW _{Hex}	[mm]	4	5	6	8	-	-	-	-
Minimum thickness of fixture for SZ-SK	t _{fix} ≥	[mm]	8/4 ³⁾	10/5 ³⁾	14/6 ³⁾	18/7 ³⁾	-	-	-	-

¹⁾ SZ-B / SZ-S, SZ-SK ²⁾ Installation torque for type SZ-SK (with countersunk head). ³⁾ Full shear load/without shear load
 For anchor designing, an easy to operate CD-ROM is available on request or can be downloaded at www.mkt.de.

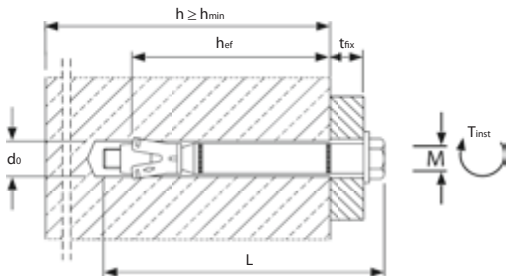

Installation

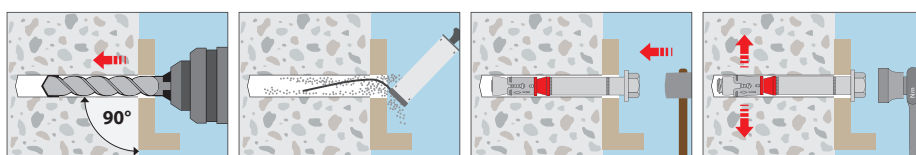

Dimensions countersunk head SZ-SK [mm]

	d1	d2	h
SZ-SK 10 M 6	16,5	9,5	3,9
SZ-SK 12 M 8	20,5	11,5	5,0
SZ-SK 15 M 10	24,5	14,5	5,7
SZ-SK 18 M 12	29,5	17,5	6,7

Countersunk head (type SZ-SK).

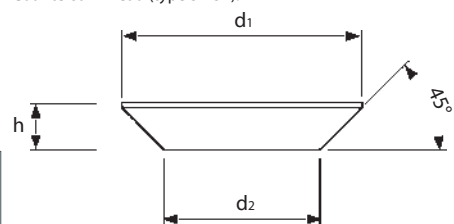

Highload Anchor SZ A4

Stainless steel A4/316



**Highload Anchor
SZ-S A4**



**Highload Anchor
SZ-B A4**

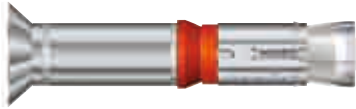

**Highload Anchor
SZ-SK A4**

Loads: 4,3 kN - 52,6 kN
Concrete quality: C20/25 - C50/60



Mechanical Heavy Duty Anchors



Description

The SZ A4/316 is the stainless-steel version of the tried and tested Highload anchor SZ. It also possesses ETA (Option 1) approval. Highload Anchor SZ is a high-performance through fastening Anchor System with three part expansion sleeve. This allows for smaller spacings and edge distances with high loads. The plastic compression ring ensures the clamping of the mounted piece to the work surface. Three different models of The Highload Anchor SZ are available: screw/washer SZ-S, Bolthead SZ-B and for a flush surface mounting SZ-SK. All models have been shock-tested by the federal office for population protection in Bern/Switzerland.

Advantages

- High tension and shear loads
- Screw/washer (SZ-S) model and flat head (SZ-SK) model for finished surfaces
- Can be dismantled with a flush surface result (only the cone and expansion sleeve remain in the drill-hole)
- smaller spacings and edge distances
- ICC Evaluation Service listing, USA
- Fire protection approved
- Approved to use under seismic action according to the performance category C1+C2

Applications

Medium to highload mounting in cracked and non-cracked concrete, e.g. trusses, railings, machines, scaffolding and consoles. Even in damp rooms and outdoors.

Highload Anchor SZ A4



- ➔ Stainless steel A4/316
- ➔ Approval for cracked and non-cracked concrete

Description	Typ SZ-S	Typ SZ-B	Drill hole Ø x depth mm	Drill hole depth through fixture mm	Setting depth mm	Anchor length l		Seismic C1 / C2	Fixture thickness t _{fix} mm	Thread	Pkg. cont. pcs.	Weight per pkg. kg
	Ref. No.	Ref. No.				Typ S mm	Typ B mm					
SZ 12-0 A4	14105501	16105501	12x80	80	70	75	79	✓/✓	0	M 8		2,93
SZ 12-10 A4	14110501	16110501	12x80	90	70	85	89	✓/✓	10	M 8	pcs.	3,31
SZ 12-30 A4	14125501	16125501	12x80	110	70	105	109	✓/✓	30	M 8	50	4,10
SZ 12-50 A4	14130501	16130501	12x80	130	70	125	129	✓/✓	50	M 8	25	2,47
SZ 12-100 A4	-	16145501	12x80	180	70	-	179	✓/✓	100	M 8	25	3,22
SZ 15-0 A4	14205501	16205501	15x95	95	85	91	95	✓/✓	0	M 10	25	2,85
SZ 15-15 A4	14215501	16215501	15x95	110	85	106	110	✓/✓	15	M 10	25	3,31
SZ 15-25 A4	14220501	16220501	15x95	120	85	116	120	✓/✓	25	M 10	25	3,59
SZ 15-45 A4	14225501	16225501	15x95	140	85	136	140	✓/✓	45	M 10	25	4,20
SZ 15-95 A4	14240501	16240501	15x95	190	85	186	190	✓/✓	95	M 10	25	5,60
SZ 18-0 A4	14305501	16305501	18x105	105	95	108	112	✓/✓	0	M 12	20	3,84
SZ 18-10 A4	14310501	16310501	18x105	115	95	118	122	✓/✓	10	M 12	20	4,18
SZ 18-20 A4	14315501	16315501	18x105	125	95	128	131	✓/✓	20	M 12	20	4,53
SZ 18-40 A4	14325501	16325501	18x105	145	95	148	151	✓/✓	40	M 12	20	5,21
SZ 18-70 A4	14335501	16335501	18x105	175	95	178	182	✓/✓	70	M 12	20	6,26
SZ 18-100 A4	-	16340501	18x105	205	95	-	212	✓/✓	100	M 12	10	3,55
SZ 24-0 A4	14505501	16505501	24x130	130	120	130	137	✓/✓	0	M 16	10	4,11
SZ 24-20 A4	14515501	16515501	24x130	150	120	150	157	✓/✓	20	M 16	10	4,71
SZ 24-50 A4	14525501	16525501	24x130	180	120	180	187	✓/✓	50	M 16	10	5,58
SZ 24-100 A4	-	16530501	24x130	230	120	-	237	✓/✓	100	M 16	5	3,49

Highload Anchor SZ-SK A4



- ➔ Stainless steel A4/316
- ➔ Approval for cracked and non-cracked concrete

Description	Ref. No.	Drill hole Ø x depth mm	Drill hole depth through fixture mm	Setting depth mm	Anchor length l mm	Seismic C1 / C2	Fixture thickness t _{fix} mm	Thread	Pkg. cont. pcs.	Weight per pkg. kg
SZ-SK 12-10 A4	14111531	12 x 80	90	70	80	✓/✓	10	M 8	50	3,01
SZ-SK 12-25 A4	14121531	12 x 80	105	70	95	✓/✓	25	M 8	50	3,65
SZ-SK 12-50 A4	14131531	12 x 80	130	70	120	✓/✓	50	M 8	25	2,33
SZ-SK 15-15 A4	14216531	15 x 95	105	85	100	✓/✓	15	M 10	25	3,07
SZ-SK 15-25 A4	14221531	15 x 95	120	85	110	✓/✓	25	M 10	25	3,29
SZ-SK 15-35 A4	14226531	15 x 95	130	85	120	✓/✓	35	M 10	25	3,55
SZ-SK 15-50 A4	14231531	15 x 95	145	85	135	✓/✓	50	M 10	25	3,96
SZ-SK 18-20 A4	14316531	18 x 105	125	95	115	✓/✓	20	M 12	20	3,99
SZ-SK 18-40 A4	14326531	18 x 105	145	95	135	✓/✓	40	M 12	20	4,62

Other lengths and special assemblies on demand.



Extract from Permissible Service Conditions of European Technical Assessment ETA-02/0030

Approved loads for single anchor without influence of spacing and edge distance.

Total safety factor as per ETAG 001 included (γ_M and γ_P). Load capacities under fire exposure see page 167.

Loads and performance data		Highload Anchor SZ A4/316		SZ 12 M 8	SZ 15 M 10	SZ 18 M 12	SZ 24 M 16
cracked concrete							
Mean ultimate loads, tension		C25/30 N_{um}	[kN]	19,8	31,6	37,2	68,8
Mean ultimate loads, shear		C25/30 V_{um}	[kN]	32,4	47,9	72,9	111,1
Approved loads, tension		C20/25 appr. N	[kN]	4,3	7,6	12,3	17,1
		C25/30 appr. N	[kN]	4,7	8,3	13,4	18,8
		C30/37 appr. N	[kN]	5,2	9,3	14,9	20,9
		C40/50 appr. N	[kN]	6,1	10,8	17,3	24,2
		C50/60 appr. N	[kN]	6,6	11,8	19,0	26,6
non-cracked concrete							
Approved loads, tension	SZ-S, SZ-SK / SZ-B	C20/25 appr. N	[kN]	7,6	11,9	16,7	24,0
		C25/30 appr. N	[kN]	8,3	13,0	18,3	26,3
		C30/37 appr. N	[kN]	9,3	14,5	20,3	29,3
		C40/50 appr. N	[kN]	9,9 / 10,8	15,7 / 16,8	22,9 / 23,6	34,0
		C50/60 appr. N	[kN]	9,9 / 11,8	15,7 / 18,4	22,9 / 25,8	37,3
cracked concrete							
Approved loads, shear	SZ-S, SZ-SK	C20/25 appr. V	[kN]	12,6	19,4	24,5	34,3
		\geq C25/30 appr. V	[kN]	12,6	19,4	26,9	37,6
Approved loads, shear	SZ-B	C20/25 appr. V	[kN]	13,7	20,5	24,5	34,3
		\geq C25/30 appr. V	[kN]	13,7	21,1	26,9	37,6
non-cracked concrete							
Approved loads, shear	SZ-S, SZ-SK	C20/25 appr. V	[kN]	12,6	19,4	32,6	48,1
		\geq C25/30 appr. V	[kN]	12,6	19,4	32,6	48,3
Approved loads, shear	SZ-B	C20/25 appr. V	[kN]	13,7	21,1	34,4	48,1
		\geq C25/30 appr. V	[kN]	13,7	21,1	35,4	52,6
cracked concrete / non-cracked concrete							
Approved bending moments	SZ-S, SZ-SK / SZ-B	appr. M	[Nm]	11,9 / 14,9	23,8 / 29,7	42,1 / 52,6	106,2 / 132,6
Spacing and edge distance							
Effective anchorage depth		h_{ef}	[mm]	60	71	80	100
Characteristic spacing		$s_{cr, N}$	[mm]	180	213	240	300
Characteristic edge distance		$c_{cr, N}$	[mm]	90	106,5	120	150
cracked concrete							
Minimum spacing / for edge distance c		s_{min} / c	[mm]	50/80	60/120	70/140	80/180
Minimum edge distance / for spacing s		c_{min} / s	[mm]	50/80	60/120	70/160	80/200
non-cracked concrete							
Minimum spacing / for edge distance c		s_{min} / c	[mm]	50/80	60/120	70/140	80/180
Minimum edge distance / for spacing s		c_{min} / s	[mm]	50/80	85/185	70/160	180/80
Minimum thickness of concrete slab		h_{min}	[mm]	120	140	160	200
Installation parameters							
Drill hole diameter		d_o	[mm]	12	15	18	24
Diameter of clearance hole in the fixture		$\leq d_f$	[mm]	14	17	20	26
Depth of drill hole		h_1	[mm]	80	95	105	130
Installation torque SZ-S / SZ-SK / SZ-B		T_{inst}	[Nm]	30 / 17,5 / 35	50 / 42,5 / 55	80 / 50 / 90	170 / - / 170
Width across nut SZ-S / SZ-B		SW	[mm]	13	17	19	24
Internal hexagon size SZ-SK		SW _{Hex}	[mm]	5	6	8	-
Minimum thickness of fixture for SZ-SK		$t_{fix} \geq$	[mm]	10 / 5 ¹⁾	14 / 6 ¹⁾	18 / 7 ¹⁾	-

¹⁾Full shear load/without shear load.

For anchor designing, an easy to operate CD-ROM is available on request or can be downloaded at www.mkt.de.

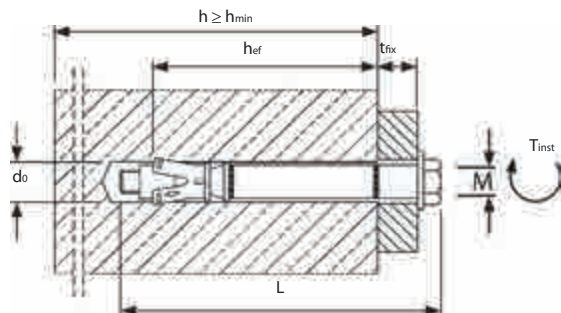

Installation

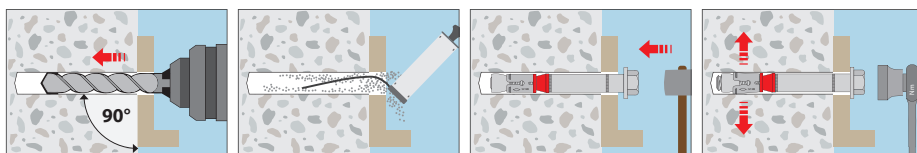

Dimensions countersunk head SZ-SK A4 [mm]

	d1	d2	h
SZ-SK 12 M 8	20,5	11,5	5,0
SZ-SK 15 M 10	24,5	14,5	5,7
SZ-SK 18 M 12	29,5	17,5	6,7

Countersunk head SZ-SK A4.

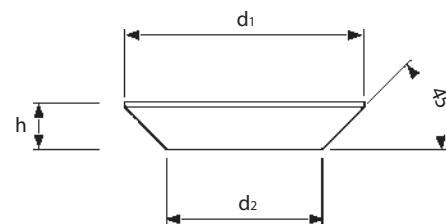

Highload Anchor SLZ

Steel, zinc plated

NEW



Highload Anchor SLZ-S

NEW



Highload Anchor SLZ-B



Range of loading: 5,7 kN – 18,7 kN
Range of concrete quality: C20/25 - C50/60

Approvals and Certificates



Description

The Highload Anchor SLZ with the diameter 14/M10 is a torque controlled sleeve anchor (ETA, Option 1) for through fastenings in cracked and non-cracked concrete. With a drill hole diameter of 14mm, it is ideal for through fastenings in pallet racks with a 15mm clearance hole. The four part extension sleeve inserts the load smoothly into the concrete. The plastic-coated cone ensures the post-expansion. Two different models of the Highload Anchor SLZ are available: SLZ-S with hexagon head and SLZ-B with threaded bolt and nut.

Advantages

- High tension and shear loads
- Screw model (SLZ-S) for finished surfaces
- Can be dismantled with a flush surface result (only the cone and expansion sleeve remain in the drill-hole)
- Small edges distances and spacings
- Ideal external diameter and diameter of drill hole for clearance holes with 15mm diameter
- Approved to use under fire exposure R30-R120

Applications

Medium to heavy duty anchoring in cracked and non-cracked concrete, e.g. pallet racks, base plates, machines.

Highload anchor SLZ-S



→ Steel, zinc plated; with hexagon head

→ Approved for cracked and non-cracked concrete

Description	Ref. No.	Drill hole Ø x depth mm	Drill hole depth through fixture mm	Setting depth mm	Anchor length l mm	Fixture thickness t _{fix} mm	Thread	Pkg. cont. pcs.	Weight per pkg. kg
SLZ-S 14-10	15260101	14x85	95	73	94	10	M10	25	2,71
SLZ-S 14-25	15270101	14x85	110	73	109	25	M10	25	3,08
SLZ-S 14-50	15275101	14x85	135	73	134	50	M10	25	3,71

Other lengths and special assemblies on demand.

Highload anchor SLZ-B



→ Steel, zinc plated; with bolt and nut

→ Approved for cracked and non-cracked concrete

Description	Ref. No.	Drill hole Ø x depth mm	Drill hole depth through fixture mm	Setting depth mm	Anchor length l mm	Fixture thickness t _{fix} mm	Thread	Pkg. cont. pcs.	Weight per pkg. kg
SLZ-B 14-25	17270101	14x85	110	73	111	25	M10	25	3,08

Other lengths and special assemblies on demand.



Extract from Permissible Service Conditions of European Technical Assessment ETA-09/0342.

Approved loads without influence of spacing and edge distance. Total safety factor as per ETAG included (γ_M and γ_F). Load capacities under fire exposure see page 167.

Loads and performance data	Highload Anchor SLZ	SLZ 14 M 10
cracked concrete		
Approved loads, tension	C20/25 appr. N [kN]	5,7
	C25/30 appr. N [kN]	6,3
	C30/37 appr. N [kN]	7,0
	C40/50 appr. N [kN]	8,1
	C50/60 appr. N [kN]	8,9
non-cracked concrete		
Approved loads, tension	C20/25 appr. N [kN]	9,5
	C25/30 appr. N [kN]	10,4
	C30/37 appr. N [kN]	11,6
	C40/50 appr. N [kN]	13,5
	C50/60 appr. N [kN]	14,8
cracked concrete		
Approved loads, shear	C20/25 appr. V [kN]	18,0
	> C25/30 appr. V [kN]	18,7
non-cracked concrete		
Approved loads, shear	C20/25 appr. V [kN]	18,7
	> C25/30 appr. V [kN]	18,7
cracked and non-cracked concrete		
Approved bending moments	appr. M [Nm]	34,3
Spacing and edge distance		
Effective anchorage depth	h_{ef} [mm]	65
Characteristic spacing	$s_{cr,N}$ [mm]	195
Characteristic edge distance	$c_{cr,N}$ [mm]	97,5
Minimum spacing / for edge distance c	$s_{min} / c \geq$ [mm]	60 / 120
Minimum edge distance / for spacing s	$c_{min} / s \geq$ [mm]	70 / 130
Minimum thickness of concrete slab	h_{min} [mm]	130
Installation parameters		
Drill hole diameter	d_o [mm]	14
Diameter of clearance hole in the fixture	$d_{r\leq}$ [mm]	16
Depth of drill hole	$h_1 \geq$ [mm]	85
Installation torque	T_{inst} [Nm]	50
Width across nut	SW [mm]	17

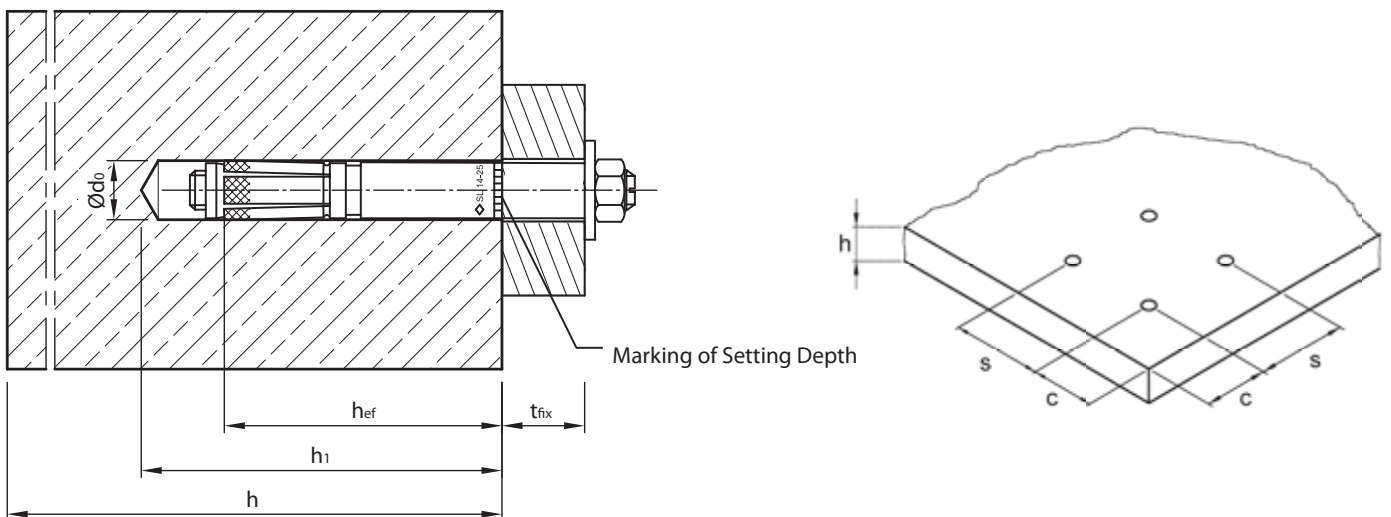

Installation

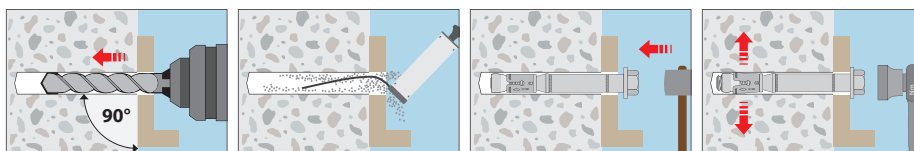

Highload Anchor SL

Steel, zinc plated / Stainless steel A4/316



Highload Anchor SL



Highload Anchor SL A4

Range of loading: 5,4 kN - 66,8 kN

Range of concrete quality: C12/15 - C50/60

Description

The Highload Anchor SL is a torque controlled sleeve anchor for through fastenings in non-cracked concrete. Three versions are available: SL-S with hexagon head screw, SL-B with hexagon nut and SL-SK with countersunk head screw. European Technical Approval, Option 7 for anchor size M10 steel galvanized. German approval in concrete strength class C12/15.

Applications

Medium to heavy duty anchorings of base plates, supports, pallet racks, brackets, railings in non-cracked concrete.



M10 zinc plated



M10 zinc plated



Highload Anchor SL



SL-B SL-S

→ Steel, zinc plated

→ For non-cracked concrete

Description	Type SL-S	Type SL-B	Drill hole Ø x depth	Drill hole depth through fixture	Setting depth mm	Anchor length		Fixture thickness	Thread	Pkg. cont.	Weight per pkg.
	Ref. No.	Ref. No.				Typ S mm	Typ B mm				
SL 14-0	10205101	12205101	14x85	85	73	84	86	0	M10	25	2,38
SL 14-10	10210101	12210101	14x85	95	73	94	96	10	M10	25	2,71
SL 14-25	10220101	12220101	14x85	110	73	109	111	25	M10	25	3,08
SL 14-50	10225101	12225101	14x85	135	73	134	136	50	M10	25	3,73
SL 14-75	10230101	12230101	14x85	160	73	159	161	75	M10	25	4,43
SL 14-100	10235101	12235101	14x85	185	73	179	181	100	M10	25	5,18
SL 14-125	-	12240101	14x85	210	73	-	210	125	M10	25	5,32
SL 14-160	-	12245101	14x85	245	73	-	245	160	M10	20	4,96

Other length and special assemblies on demand.

Highload Anchor SL A4¹⁾



SL-B SL-S

→ Stainless steel A4/316

→ For non-cracked concrete

Description	Type SL-S	Type SL-B	Drill hole Ø x depth	Drill hole depth through fixture	Setting depth mm	Anchor length		Fixture thick- ness	Thread	Pkg. cont.	Weight per pkg.
	Ref. No.	Ref. No.				Typ S mm	Typ B mm				
SL 10-10 A4	10010501	12010501	10x60	70	53	69	69	10	M 6	50	1,73
SL 10-25 A4	10020501	12020501	10x60	85	53	84	84	25	M 6	50	2,15
SL 10-50 A4	10025501	12025501	10x60	110	53	104	106	50	M 6	50	2,69
SL 14-10 A4	10210501	12210501	14x85	95	73	94	96	10	M 10	25	2,60
SL 14-25 A4	10220501	12220501	14x85	110	73	109	111	25	M 10	25	3,02
SL 14-50 A4	10225501	12225501	14x85	135	73	134	136	50	M 10	25	3,68
SL 28-30 A4	10610501	12610501	28x150	180	135	182	188	30	M 20	5	4,30
SL 28-60 A4	10615501	12615501	28x150	210	135	212	218	60	M 20	5	5,02

Other length and special assemblies on demand.

¹⁾ Not part of approvals.

Highload Anchor SL-SK A4¹⁾



→ Stainless steel A4/316

→ For non-cracked concrete

SL-SK

Description	Type SL-SK	Drill hole Ø x depth	Drill hole depth through fixture	Setting depth	Anchor length	Fixture thickness t_{fx}	Thread	Pkg. cont.	Weight per pkg.
	Ref. No.	mm	mm	mm	mm	mm		pcs.	kg
SL 10-25 A4	10020531	10x60	85	53	86	31	M 6	50	2,32

Other length and special assemblies on demand.

¹⁾ Not part of approvals.



Extract from Permissible Service Conditions of ETA-08/0230 and Z-21.1-1638.

Approved loads for single anchor without influence of spacing and edge distance.

Total safety factor as per ETAG 001 included (γ_M and γ_P).

Recommended loads for single anchor without influence of spacing and edge distance.

Total safety factor as per ETAG 001 included (γ_M and γ_P).

Loads and performance data	Highload Anchor SL		SL 14 M 10	SL 10 ¹⁾ M 6	SL 14 ¹⁾ M 10	SL 28 ¹⁾ M 20
			steel, zinc pltd.	A4-70	A4-70	A4-70
approved values - non-cracked concrete						
Mean ultimate loads, tension	C25/30 N_{um}	[kN]	43,3	15,9	40,8	160,8
	C25/30 N_{um}	[kN]	35,6	20,8	45,3	208,7
Loads, tension	C12/15 N	[kN]	7,6	-	-	-
	C20/25 N	[kN]	9,5	5,4	12,6	33,5
	C30/37 N	[kN]	11,6	5,4	13,8	36,9
	C40/50 N	[kN]	13,4	5,4	15,5	47,3
	C50/60 N	[kN]	14,8	5,4	15,5	52,0
Loads, shear	C12/15 V	[kN]	13,3	-	-	-
	\geq C20/25 V	[kN]	13,3	6,7	14,5	66,8
Bending moments	M	[Nm]	34,3	4,9	23,9	208,1
Spacing and edge distance						
Effective anchorage depth	h_{ef}	[mm]	65	45	65	125
Characteristic spacing	$s_{cr,N}$	[mm]	195	135	195	375
Characteristic edge distance	$c_{cr,N}$	[mm]	97,5	67,5	97,5	187,5
Minimum spacing	s_{min}	[mm]	60	70	100	190
Minimum edge distance	c_{min}	[mm]	120	90	130	250
Minimum thickness of concrete slab	h_{min}	[mm]	130	130	200	350
Installation parameters						
Drill hole diameter	d_o	[mm]	14	10	14	28
Diameter of clearance hole in the fixture	d_f	[mm]	16	12	16	31
Depth of drill hole	h_1	[mm]	85	60	85	150
Installation torque	T_{inst}	[Nm]	50	10	50	400
Width across nut	SW	[mm]	17	10	17	30

For anchor designing an easy to operate CD-ROM is available on request or can be downloaded at www.mkt.de.

¹⁾ Not part of approvals.

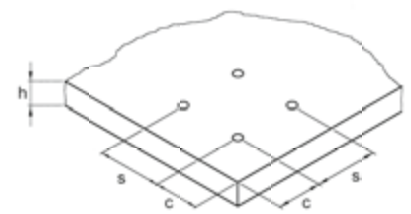
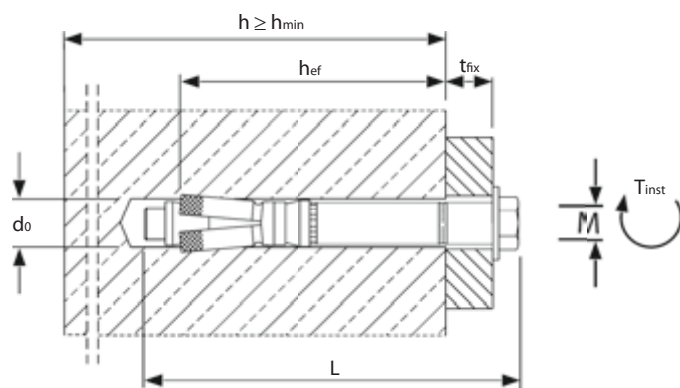

Dimensions countersunk head SL-SK [mm]

	d1	d2	h
SL-SK 10 M 6	20,0	11,0	6,0

Countersunk head version SL-SK.

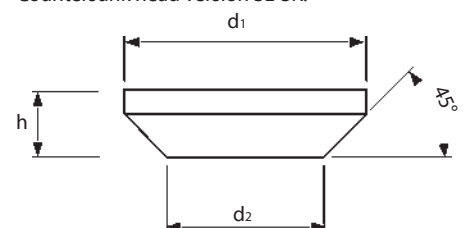

Installation

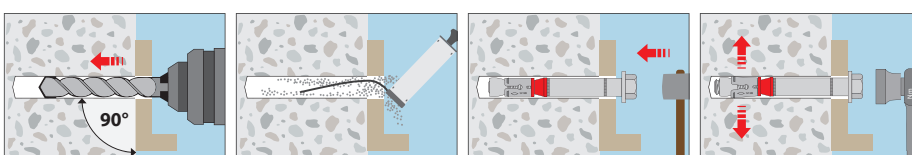

Concrete screw BSZ

Steel zinc plated/Steel zinc flake coated

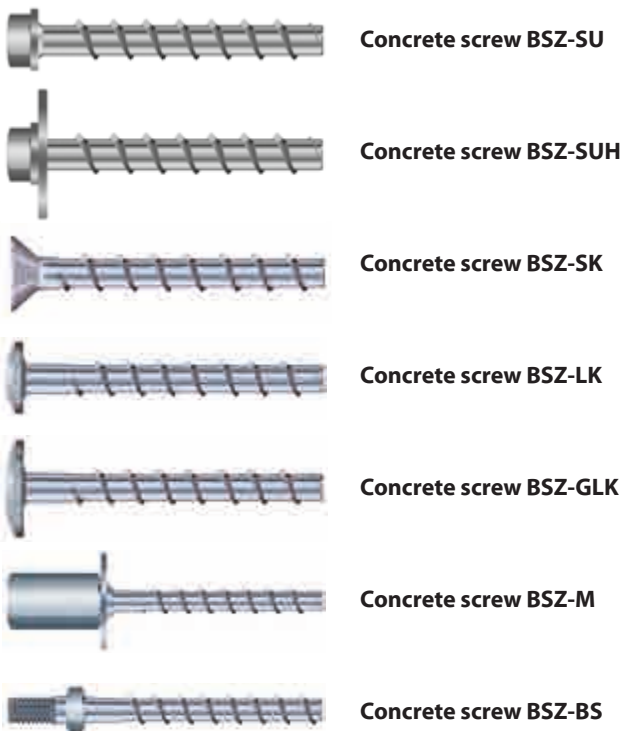

Approvals and Certificates

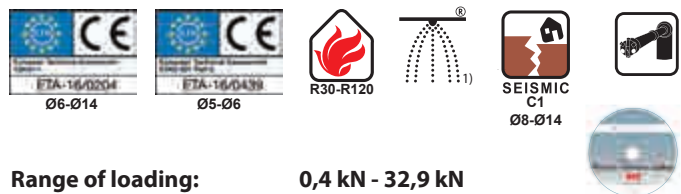

Range of loading: 0,4 kN - 32,9 kN
Range of concrete quality: C20/25 - C50/60

Description

Option 1 approved concrete screw BSZ cut a positive thread in the concrete when being screwed in and enable attachment to be made close to the edge through the expansion-free operating principle (=undercut). The approved adjustment enables subsequent alignment to compensate for unevenness. The concrete screw BSZ is also ideal for temporary fixings since it is fully removable. Installation with an impact screwdriver means that you do not need to use a torque wrench. It is quick, reliable and reduces assembly errors.

The concrete screw BSZs are available with connection thread and with a range of different head shapes for a wide variety of applications. The versions with hex head have a special zinc flake coating.

Advantages

- European Technical Assessment for anchoring in cracked and non-cracked concrete (Option 1) for concrete screws in sizes 6, 8, 10, 12 and 14
- With up to 3 embedment depths, it is versatile for high loads or low levels of drilling and installation effort
- European Technical Assessment for multiple use for non-structural systems in concrete and precast pre-stressed hollow core slabs for concrete screws in sizes 5 and 6
- Approved for use under seismic conditions of category C1 (Ø8 to Ø14 for embedment depth h_{nom} 3)
- Approved for use under fire exposure (R30-R120).
- Small drill hole diameter, small edge and axial gap
- Rapid push-through installation with an impact screwdriver without torque regulation
- No curing times, can be loaded immediately
- Adjustable to compensate for unevenness (Ø8- Ø14 mm)
- Can be fully removed
- Wide range of possible applications through numerous variants

¹⁾Not for applications in precast pre-stressed hollow core slabs

- Visually appealing through different head shapes
- Without approval, can also be used in compression-resistant natural stone, various solid bricks and green concrete

Applications

To anchor moderate to heavy loads in cracked and non-cracked concrete: Railings and handrails, shelves, wooden beams, supports and braces, brackets, pipeline and cable routes, suspended ceilings, etc.

Highly versatile for up to three different embedment depths:

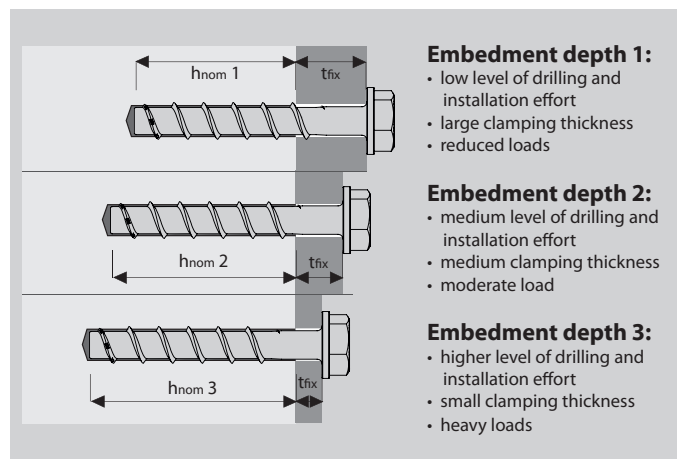

Concrete screw BSZ-SU



- ➔ Hex head with pressed disc
- ➔ Steel, zinc flake coated
- ➔ Through smaller drive with pressed disc also suitable for areas, where access is difficult, and elongated holes (e.g. mounting rails)

Description	Ref. No.	Embedment depth h 1 ¹⁾			Embedment depth h 2			Embedment depth h 3				Anchor length L	Pressed disc Ø	Drive	Pkg. content	Weight per pkg.
		Fixture thickness t _{fix}	Drill hole Ø x depth	Embedment depth h _{nom 1}	Fixture thickness t _{fix}	Drill hole Ø x depth	Embedment depth h _{nom 2}	Fixture thickness t _{fix}	Drill hole Ø x depth	Embedment depth h _{nom 3}	Seismic C1					
BSZ-SU 5x40 ZL	58111201	5	5x40	35	-	-	-	-	-	-	-	40	12,5	SW 10	100	0,96
BSZ-SU 5x50 ZL	58111701	15	5x40	35	-	-	-	-	-	-	-	50	12,5	SW 10	100	1,12
BSZ-SU 5x60 ZL	58112201	25	5x40	35	-	-	-	-	-	-	-	60	12,5	SW 10	100	1,26
BSZ-SU 6x40 ZL	58121201	5	6x40	35	-	-	-	-	-	-	-	40	15	SW 13	100	1,51
BSZ-SU 6x50 ZL	58121701	15	6x40	35	10	6x45	40	-	-	-	-	50	15	SW 13	100	1,73
BSZ-SU 6x60 ZL	58122201	25	6x40	35	20	6x45	40	5	6x60	55	-	60	15	SW 13	100	1,93
BSZ-SU 6x80 ZL	58123201	45	6x40	35	40	6x45	40	25	6x60	55	-	80	15	SW 13	100	2,33
BSZ-SU 6x100 ZL	58124201	65	6x40	35	60	6x45	40	45	6x60	55	-	100	15	SW 13	100	2,73
BSZ-SU 8x50 ZL	58131201	5	8x55	45	-	-	-	-	-	-	-	50	16	SW 13	50	1,58
BSZ-SU 8x60 ZL	58131701	15	8x55	45	5	8x65	55	-	-	-	-	60	16	SW 13	50	1,78
BSZ-SU 8x70 ZL	58132201	25	8x55	45	15	8x65	55	5	8x75	65	✓	70	16	SW 13	50	1,97
BSZ-SU 8x80 ZL	58132701	35	8x55	45	25	8x65	55	15	8x75	65	✓	80	16	SW 13	50	2,16
BSZ-SU 8x90 ZL	58133201	45	8x55	45	35	8x65	55	25	8x75	65	✓	90	16	SW 13	50	2,35
BSZ-SU 8x100 ZL	58133701	55	8x55	45	45	8x65	55	35	8x75	65	✓	100	16	SW 13	50	2,57
BSZ-SU 8x120 ZL	58134701	75	8x55	45	65	8x65	55	55	8x75	65	✓	120	16	SW 13	50	2,95
BSZ-SU 8x140 ZL	58135701	95	8x55	45	85	8x65	55	75	8x75	65	✓	140	16	SW 13	50	3,33
BSZ-SU 10x60 ZL	58141201	5	10x65	55	-	-	-	-	-	-	-	60	20	SW 15	50	2,82
BSZ-SU 10x70 ZL	58141701	15	10x65	55	-	-	-	-	-	-	-	70	20	SW 15	50	3,12
BSZ-SU 10x80 ZL	58142201	25	10x65	55	5	10x85	75	-	-	-	-	80	20	SW 15	50	3,42
BSZ-SU 10x90 ZL	58142701	35	10x65	55	15	10x85	75	5	10x95	85	✓	90	20	SW 15	50	3,72
BSZ-SU 10x100 ZL	58143201	45	10x65	55	25	10x85	75	15	10x95	85	✓	100	20	SW 15	50	4,03
BSZ-SU 10x120 ZL	58144201	65	10x65	55	45	10x85	75	35	10x95	85	✓	120	20	SW 15	50	4,63
BSZ-SU 10x140 ZL	58145201	85	10x65	55	65	10x85	75	55	10x95	85	✓	140	20	SW 15	50	5,26
BSZ-SU 10x160 ZL	58146201	105	10x65	55	85	10x85	75	75	10x95	85	✓	160	20	SW 15	50	5,86
BSZ-SU 12x80 ZL	58151201	15	12x75	65	-	-	-	-	-	-	-	80	23,5	SW 17	25	2,32
BSZ-SU 12x110 ZL	58152701	45	12x75	65	25	12x95	85	10	12x110	100	✓	110	23,5	SW 17	25	2,95
BSZ-SU 12x130 ZL	58153701	65	12x75	65	45	12x95	85	30	12x110	100	✓	130	23,5	SW 17	25	3,40
BSZ-SU 12x150 ZL	58154701	85	12x75	65	65	12x95	85	50	12x110	100	✓	150	23,5	SW 17	25	3,82
BSZ-SU 14x80 ZL	58161201	5	14x85	75	-	-	-	-	-	-	-	80	28	SW 21	25	3,38
BSZ-SU 14x110 ZL	58162701	35	14x85	75	10	14x110	100	-	-	-	-	110	28	SW 21	25	4,22
BSZ-SU 14x130 ZL	58163701	55	14x85	75	30	14x110	100	15	14x125	115	✓	130	28	SW 21	25	4,82
BSZ-SU 14x150 ZL	58164701	75	14x85	75	50	14x110	100	35	14x125	115	✓	150	28	SW 21	25	5,40

¹⁾For embedment depth h_{nom 1} = 35 mm: Only for multiple use for non-structural systems in concrete and precast pre-stressed hollow core slabs.

Concrete screw BSZ-SUH



- ➔ Hex head with pressed disc and large washer EN ISO 7094 (DIN 440)
- ➔ Steel, zinc flake coated
- ➔ For fixing purlins and wooden beams onto concrete

Description	Ref. No.	Embedment depth h _{nom 1}			Embedment depth h _{nom 2}			Embedment depth h _{nom 3}				Anchor length L	Drive	Washer ²⁾	Pkg. content	Weight per pkg.
		Fixture thickness t _{fix}	Drill hole Ø x depth	Embedment depth h _{nom 1}	Fixture thickness t _{fix}	Drill hole Ø x depth	Embedment depth h _{nom 2}	Fixture thickness t _{fix}	Drill hole Ø x depth	Embedment depth h _{nom 3}	Seismic C1					
BSZ-SUH 10x180 ZL	58246701	121	10x65	55	101	10x85	75	91	10x95	85	✓	180	SW 15	44x4	25	4,34
BSZ-SUH 10x200 ZL	58247201	141	10x65	55	121	10x85	75	111	10x95	85	✓	200	SW 15	44x4	25	4,64
BSZ-SUH 10x240 ZL	58247701	181	10x65	55	161	10x85	75	151	10x95	85	✓	240	SW 15	44x4	25	5,25
BSZ-SUH 10x280 ZL	58248201	221	10x65	55	201	10x85	75	191	10x95	85	✓	280	SW 15	44x4	25	5,94
BSZ-SUH 10x320 ZL	58248701	261	10x65	55	241	10x85	75	231	10x95	85	✓	320	SW 15	44x4	25	6,54

²⁾Outer diameter x thickness

Concrete screw BSZ-SK



- Countersunk head with Torx drive
- Steel, zinc plated
- For installations being flush with the fixture

Description	Ref. No.	Embedment depth 1 ¹⁾			Embedment depth 2			Embedment depth 3			Seismic C1	Anchor length L	Head-Ø	Drive	Pkg. content	Weight per pkg.
		Fixture thickness t _{fix} mm	Drill hole Ø x depth mm	Embedment depth h _{nom} 1 mm	Fixture thickness t _{fix} mm	Drill hole Ø x depth mm	Embedment depth h _{nom} 2 mm	Fixture thickness t _{fix} mm	Drill hole Ø x depth mm	Embedment depth h _{nom} 3 mm						
BSZ-SK 5x40	58311001	5	5x40	35	-	-	-	-	-	-	-	40	12	T 30	100	0,78
BSZ-SK 5x50	58311501	15	5x40	35	-	-	-	-	-	-	-	50	12	T 30	100	0,94
BSZ-SK 5x60	58312001	25	5x40	35	-	-	-	-	-	-	-	60	12	T 30	100	1,08
BSZ-SK 6x40	58321001	5	6x40	35	-	-	-	-	-	-	-	40	13	T 30	100	0,99
BSZ-SK 6x50	58321501	15	6x40	35	10	6x45	40	-	-	-	-	50	13	T 30	100	1,20
BSZ-SK 6x60	58322001	25	6x40	35	20	6x45	40	5	6x60	55	-	60	13	T 30	100	1,41
BSZ-SK 6x80	58323001	45	6x40	35	40	6x45	40	25	6x60	55	-	80	13	T 30	100	1,85
BSZ-SK 6x100	58324001	65	6x40	35	60	6x45	40	45	6x60	55	-	100	13	T 30	100	2,27
BSZ-SK 6x120	58325001	85	6x40	35	80	6x45	40	65	6x60	55	-	120	13	T 30	100	2,69
BSZ-SK 6x140	58326001	105	6x40	35	100	6x45	40	85	6x60	55	-	140	13	T 30	100	3,11
BSZ-SK 8x80	58332501	35	8x55	45	25	8x65	55	15	8x75	65	✓	80	19,5	T 40	50	1,95
BSZ-SK 10x90	58342501	35	10x65	55	15	10x85	75	5	10x95	85	✓	90	21,5	T 50	50	3,10

¹⁾For embedment depth h_{nom} 1 = 35 mm: Only for multiple use for non-structural systems in concrete and precast pre-stressed hollow core slabs.

Concrete screw BSZ-LK



- Pan head with Torx drive
- Steel, zinc plated
- For a flat fixing which has a high-quality look

Description	Ref. No.	Embedment depth 1 ¹⁾			Embedment depth 2			Embedment depth 3			Seismic C1	Anchor length L	Head-Ø	Drive	Pkg. content	Weight per pkg.
		Fixture thickness t _{fix} mm	Drill hole Ø x depth mm	Embedment depth h _{nom} 1 mm	Fixture thickness t _{fix} mm	Drill hole Ø x depth mm	Embedment depth h _{nom} 2 mm	Fixture thickness t _{fix} mm	Drill hole Ø x depth mm	Embedment depth h _{nom} 3 mm						
BSZ-LK 5x40	58411001	5	5x40	35	-	-	-	-	-	-	-	40	14	T 30	100	0,83
BSZ-LK 5x50	58411501	15	5x40	35	-	-	-	-	-	-	-	50	14	T 30	100	0,97
BSZ-LK 5x60	58412001	25	5x40	35	-	-	-	-	-	-	-	60	14	T 30	100	1,11
BSZ-LK 6x40	58421001	5	6x40	35	-	-	-	-	-	-	-	40	14,5	T 30	100	1,18
BSZ-LK 6x50	58421501	15	6x40	35	10	6x45	40	-	-	-	-	50	14,5	T 30	100	1,41
BSZ-LK 6x60	58422001	25	6x40	35	20	6x45	40	5	6x60	55	-	60	14,5	T 30	100	1,59
BSZ-LK 6x80	58423001	45	6x40	35	40	6x45	40	25	6x60	55	-	80	14,5	T 30	100	2,03
BSZ-LK 6x100	58424001	65	6x40	35	60	6x45	40	45	6x60	55	-	100	14,5	T 30	100	2,45

¹⁾For embedment depth h_{nom} 1 = 35 mm: Only for multiple use for non-structural systems in concrete and precast pre-stressed hollow core slabs.

Concrete screw BSZ-GLK



- Large pan head with Torx drive
- Steel, zinc plated
- For fixing mounting rails

Description	Ref. No.	Embedment depth 1 ¹⁾			Embedment depth 2			Embedment depth 3			Seismic C1	Anchor length L	Head-Ø	Drive	Pkg. content	Weight per pkg.
		Fixture thickness t _{fix} mm	Drill hole Ø x depth mm	Embedment depth h _{nom} 1 mm	Fixture thickness t _{fix} mm	Drill hole Ø x depth mm	Embedment depth h _{nom} 2 mm	Fixture thickness t _{fix} mm	Drill hole Ø x depth mm	Embedment depth h _{nom} 3 mm						
BSZ-GLK 6x40	58521001	5	6x40	35	-	-	-	-	-	-	-	40	18	T 30	100	1,35
BSZ-GLK 6x60	58522001	25	6x40	35	20	6x45	40	5	6x60	55	-	60	18	T 30	100	1,81

¹⁾For embedment depth h_{nom} 1 = 35 mm: Only for multiple use for non-structural systems in concrete and precast pre-stressed hollow core slabs.

Concrete screw BSZ-M



- Socket with connecting thread M8/M10 and hex drive
- Steel, zinc plated
- For direct attachment of threaded rods

Description	Ref. No.	Embedment depth 1 ¹⁾			Embedment depth 2			Embedment depth 3			Seismic C1	Anchor length L	Con-necting thread	Washer-Ø	Drive	Pkg. content	Weight per pkg.
		Fixture thickness t _{fix}	Drill hole Ø x depth	Embedment depth h _{nom 1}	Fixture thickness t _{fix}	Drill hole Ø x depth	Embedment depth h _{nom 2}	Fixture thickness t _{fix}	Drill hole Ø x depth	Embedment depth h _{nom 3}							
		mm	mm	mm	mm	mm	mm	mm	mm	mm							
BSZ-M 6x35	58621001	0	6x40	35	-	-	-	-	-	-	-	35	M8/10 IG	25	SW 13	50	1,77
BSZ-M 6x55	58622001	20	6x40	35	15	6x45	40	0	6x60	55	-	55	M8/10 IG	25	SW 13	50	1,97

¹⁾For embedment depth h_{nom 1} = 35 mm: Only for multiple use for non-structural systems in concrete and precast pre-stressed hollow core slabs.

Concrete screw BSZ-BS



- Hanger bolt with metric connection thread and hex drive
- Steel, zinc plated
- To connect pipe clamps and threaded sockets

Description	Ref. No.	Embedment depth 1 ¹⁾			Embedment depth 2			Embedment depth 3			Seismic C1	Anchor length L	Con-nection thread	Drive	Pkg. content	Weight per pkg.
		Fixture thickness t _{fix}	Drill hole Ø x depth	Embedment depth h _{nom 1}	Fixture thickness t _{fix}	Drill hole Ø x depth	Embedment depth h _{nom 2}	Fixture thickness t _{fix}	Drill hole Ø x depth	Embedment depth h _{nom 3}						
		mm	mm	mm	mm	mm	mm	mm	mm	mm						
BSZ-BS 6x35	58721001	0	6x40	35	-	-	-	-	-	-	-	35	M8x16	SW 10	100	1,63
BSZ-BS 6x55	58722001	20	6x40	35	15	6x45	40	0	6x60	55	-	55	M8x16	SW 10	100	1,88
BSZ-BS 6x75	58723001	40	6x40	35	35	6x45	40	20	6x60	55	-	75	M8x16	SW 10	100	2,30
BSZ-BS 6x95	58724001	60	6x40	35	55	6x45	40	40	6x60	55	-	95	M8x16	SW 10	100	2,71

¹⁾For embedment depth h_{nom 1} = 35 mm: Only for multiple use for non-structural systems in concrete and precast pre-stressed hollow core slabs.

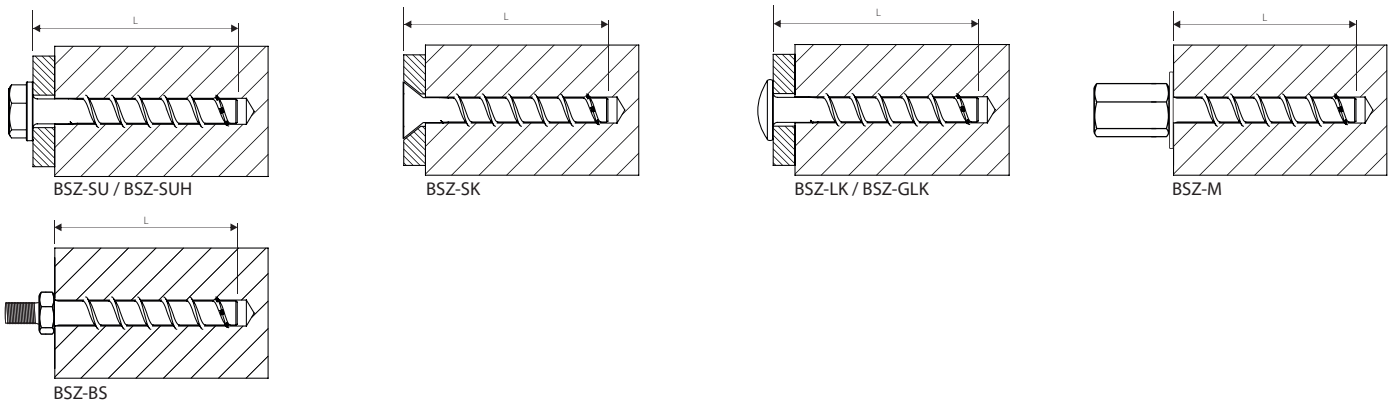

Recommended impact screwdriver

Description of concrete screw	recommended impact screwdriver
BSZ 5	<ul style="list-style-type: none"> • Milwaukee C 12 IW (Square drive, Battery operation, max. torque 136 Nm) • Milwaukee C 12ID (Multi-toothed drive, Battery operation, max. torque 96 Nm) • Würth ASS 10-A (Battery operation, max. torque 105 Nm)
BSZ 6	<ul style="list-style-type: none"> • Milwaukee C 12 IW (Square drive, Battery operation, max. torque 136 Nm) • Milwaukee C 12ID (Multi-toothed drive, Battery operation, max. torque 96 Nm) • DeWalt DEDC 840 KB (Square drive, Battery operation, max. torque 160 Nm) • Würth ASS 14 (1/4 inch drive, Battery operation, max. torque 150 Nm)
BSZ 8 BSZ 10	<ul style="list-style-type: none"> • Milwaukee C 18 IW (Square drive, Battery operation, max. torque 250 Nm) • Bosch GDS 18E (Square drive, Mains operation, max. torque 250 Nm) • Makita 6905H (Square drive, Mains operation, max. torque 300 Nm) • Würth ASS 18 (1/2 inch drive, Battery operation, max. torque 180 Nm) • Würth ESS (1/2 inch drive, Mains operation, max. torque 250 Nm)
BSZ 12 BSZ 14	<ul style="list-style-type: none"> • Milwaukee HD 28 IW (Square drive, Battery operation, max. torque 440 Nm) • Bosch GDS 18E (Square drive, Mains operation, max. torque 250 Nm) • Makita 6905H (Square drive, Mains operation, max. torque 300 Nm) • Würth ASS 18 (1/2 inch drive HAT, Battery operation, max. torque 610 Nm) • Würth ESS (1/2 inch drive, Mains operation, max. torque 250 Nm)

Subsequent adjustment

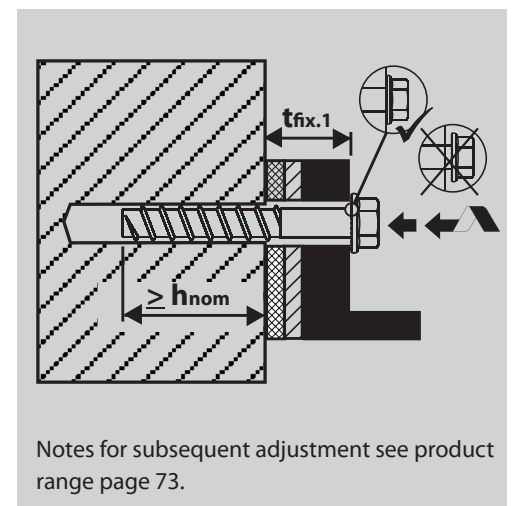



Excerpt from the application conditions of the European Technical Assessment ETA-16/0204

Approved loads for single anchor without influence of spacing and edge distance.

 Total safety factor as per ETAG 001 included (γ_M and γ_F). Load capacities under fire exposure see page 167.

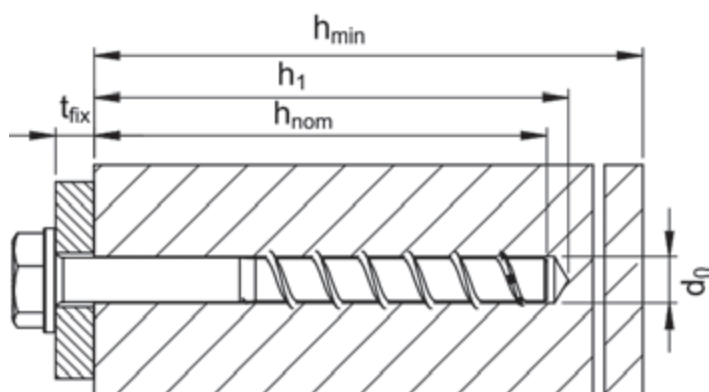
Loads and performance data		Concrete screw size		BSZ 6		BSZ 8		BSZ 10		BSZ 12		BSZ 14					
Nominal embedment depth 1	$h_{nom 1}$	[mm]	-	-	45	-	-	55	-	-	65	-	-	75	-	-	
Nominal embedment depth 2	$h_{nom 2}$	[mm]	40	-	-	55	-	-	75	-	-	85	-	-	100	-	
Nominal embedment depth 3	$h_{nom 3}$	[mm]	-	55	-	-	65	-	-	85	-	-	100	-	-	115	
cracked concrete																	
Approved loads, tension	C20/25	appr. N	[kN]	1,0	1,9	2,4	4,3	5,7	4,3	8,0	9,6	5,7	9,4	12,3	7,6	12,0	15,1
	C25/30	appr. N	[kN]	1,0	2,1	2,6	4,7	6,3	4,7	8,7	10,5	6,3	10,3	13,4	8,3	13,2	16,6
	C30/37	appr. N	[kN]	1,2	2,3	2,9	5,2	7,0	5,2	9,7	11,7	7,0	11,4	14,9	9,2	14,6	18,4
	C40/50	appr. N	[kN]	1,3	2,7	3,4	6,1	8,1	6,1	11,3	13,6	8,1	13,3	17,3	10,7	17,0	21,4
	C50/60	appr. N	[kN]	1,5	3,0	3,7	6,6	8,9	6,6	12,3	14,9	8,9	14,6	19,0	11,7	18,6	23,4
non-cracked concrete																	
Approved loads, tension	C20/25	appr. N	[kN]	1,9	4,3	3,6	5,7	7,6	5,7	9,5	11,9	7,6	13,2	17,2	10,6	16,9	21,2
	C25/30	appr. N	[kN]	2,1	4,7	3,9	6,3	8,3	6,3	10,4	13,0	8,3	14,4	18,8	11,6	18,5	23,2
	C30/37	appr. N	[kN]	2,3	5,2	4,3	7,0	9,3	7,0	11,6	14,5	9,3	16,0	20,9	12,9	20,5	25,8
	C40/50	appr. N	[kN]	2,7	6,1	5,1	8,1	10,8	8,1	13,5	16,8	10,8	18,7	24,3	15,0	23,9	30,0
	C50/60	appr. N	[kN]	3,0	6,6	5,5	8,9	11,8	8,9	14,8	18,4	11,8	20,4	26,7	16,5	26,2	32,9
cracked / non-cracked concrete																	
Approved loads, shear	C20/25	appr. V	[kN]	3,0/4,0	4,0/4,0	3,5/5,0	4,8/6,8	6,4/9,0	4,8/6,8	15,9/19,4	19,2/19,4	6,1/8,5	18,8/24,0	24,0/24,0	7,6/10,6	24,1/32,0	30,3/32,0
	\geq C25/30	appr. V	[kN]	3,2/4,0	4,0/4,0	3,9/5,5	5,3/7,4	7,0/9,7	5,3/7,4	17,5/19,4	19,4/19,4	6,6/9,3	20,6/24,0	24,0/24,0	8,3/11,6	26,4/32,0	32,0/32,0
Approved bending moments	appr. M	[Nm]	6,2	6,2	14,9	14,9	14,9	32,0	32,0	32,0	64,6	64,6	64,6	105,7	105,7	105,7	
Spacing and edge distance																	
Effective anchorage depth	h_{ef}	[mm]	31	44	35	43	52	43	60	68	50	67	80	58	79	92	
Characteristic spacing	$s_{cr, N}$	[mm]	93	132	105	129	156	129	180	204	150	201	240	174	237	276	
Characteristic edge distance	$c_{cr, N}$	[mm]	46,5	66	52,5	64,5	78	64,5	90	102	75	100,5	120	87	118,5	138	
Minimum thickness of concrete slab	h_{min}	[mm]	100	100	100	100	120	100	130	130	120	130	150	130	150	170	
Minimum spacing	s_{min}	[mm]	40	40	40	50	50	50	50	50	50	50	70	50	70	70	
Minimum edge distance	c_{min}	[mm]	40	40	40	50	50	50	50	50	50	50	70	50	70	70	
Installation parameters																	
Drill hole diameter	d_o	[mm]	6	6	8	8	8	10	10	10	12	12	12	14	14	14	
Diameter of clearance hole in the fixture	$d_{f \leq}$	[mm]	8	8	12	12	12	14	14	14	16	16	16	18	18	18	
Depth of drill hole	$h_{i \geq}$	[mm]	45	60	55	65	75	65	85	95	75	95	110	85	110	125	
Installation torque with metric connection thread	$T_{inst \leq}$	[Nm]	10	10	20	20	20	40	40	40	60	60	60	80	80	80	
Tangential impact screwdriver ¹⁾	$T_{imp, max}$	[Nm]	160	160	300	300	300	400	400	400	500	500	500	500	500	500	

¹⁾It is possible to fit with a tangential screwdriver with maximum output of $T_{imp, max}$ in accordance with the manufacturer's specifications



Extract from Permissible Service Conditions of European Technical Assessment ETA-16/0439

Multiple use for non-structural applications. Total safety factor as per ETAG 001 included (γ_M and γ_F). Depending on national regulations, the maximum allowable load per fixing point may be lower than the approved load of the anchor. The allowable loads per fixing point are regulated for the particular countries in the ETAG 001, Part 6.

Loads and performance data		Concrete screw size		BSZ 5	BSZ 6	
Nominal embedment depth 1	$h_{nom 1}$	[mm]	35	35	-	
Nominal embedment depth 2	$h_{nom 2}$	[mm]	-	-	-	
Nominal embedment depth 3	$h_{nom 3}$	[mm]	-	-	55	
cracked concrete						
Approved loads, tension	C20/25	appr. N	[kN]	0,6	0,6	3,6
	C25/30	appr. N	[kN]	0,7	0,7	3,9
	C30/37	appr. N	[kN]	0,7	0,7	4,3
	C40/50	appr. N	[kN]	0,8	0,8	5,1
	C50/60	appr. N	[kN]	0,9	0,9	5,5
non-cracked concrete						
Approved loads, tension	C20/25	appr. N	[kN]	0,6	0,6	3,6
	C25/30	appr. N	[kN]	0,7	0,7	3,9
	C30/37	appr. N	[kN]	0,7	0,7	4,3
	C40/50	appr. N	[kN]	0,8	0,8	5,1
	C50/60	appr. N	[kN]	0,9	0,9	5,5
cracked / non-cracked concrete						
Approved loads, shear	C20/25	appr. V	[kN]	2,0/2,5	2,0/2,8	4,0/4,0
	\geq C25/30	appr. V	[kN]	2,2/2,5	2,2/3,1	4,0/4,0
Approved bending moments		appr. M	[Nm]	3	6,2	6,2
Spacing and edge distance						
Effective anchorage depth	h_{ef}	[mm]	27	27	44	
Characteristic spacing	$s_{cr, N}$	[mm]	81	81	132	
Characteristic edge distance	$c_{cr, N}$	[mm]	40,5	40,5	66	
Minimum thickness of concrete slab	h_{min}	[mm]	80	80	100	
Minimum spacing	s_{min}	[mm]	35	35	40	
Minimum edge distance	c_{min}	[mm]	35	35	40	
Installation parameters						
Drill hole diameter	d_o	[mm]	5	6	6	
Diameter of clearance hole in the fixture	d_f	[mm]	7	8	8	
Depth of drill hole	$h_{1 \geq}$	[mm]	40	40	60	
Installation torque with metric connection thread	$T_{inst \leq}$	[Nm]	8	10	10	
Tangential impact screwdriver ¹⁾	$T_{imp, max}$	[Nm]	110	160	160	

¹⁾It is possible to fit with a tangential screwdriver with maximum output of $T_{imp, max}$ in accordance with the manufacturer's specifications

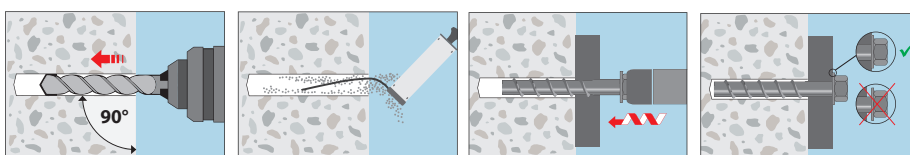
Approved loads with exposure to fire						
in cracked and non-cracked concrete C20/25 to C50/60						
Approved loads, tension	R30	appr. N_{fi}	[kN]	-	0,38	0,9
	R60	appr. N_{fi}	[kN]	-	0,38	0,8
	R90	appr. N_{fi}	[kN]	-	0,38	0,6
	R120	appr. N_{fi}	[kN]	-	0,3	0,4
Approved loads, shear	R30	appr. V_{fi}	[kN]	-	0,68	0,9
	R60	appr. V_{fi}	[kN]	-	0,68	0,8
	R90	appr. V_{fi}	[kN]	-	0,6	0,6
	R120	appr. V_{fi}	[kN]	-	0,4	0,4
Characteristic spacing	$s_{cr, fi}$	[mm]	-	108	176	
Characteristic edge distance	$c_{cr, fi}$	[mm]	-	54	88	

Installation



Extract from Permissible Service Conditions of European Technical Assessment ETA-16/0439

Multiple use for non-structural applications. Total safety factor as per ETAG 001 included (γ_M and γ_F). Depending on national regulations, the maximum allowable load per fixing point may be lower than the approved load of the anchor. The allowable loads per fixing point are regulated for the particular countries in the ETAG 001, Part 6.

Loads and performance data		Concrete screw size		BSZ 6
Nominal embedment depth	h_{nom} [mm]			≥ 35
Precast pre-stressed hollow core slabs C30/37 to C50/60				
Flange thickness	$d_b \geq$ [mm]	25	30	35
	F_{appr} [kN]	0,4	0,8	1,2
Spacing and edge distance				
Minimum spacing	s_{min} [mm]			100
Minimum edge distance	c_{min} [mm]			100
Installation parameters				
Drill hole diameter	d_o [mm]			6
Diameter of clearance hole in the fixture	d_f [mm]			8
Depth of drill hole	$h_1 \geq$ [mm]			40
Installation torque	$T_{inst} \leq$ [Nm]			10

Installation in precast pre-stressed hollow core slabs

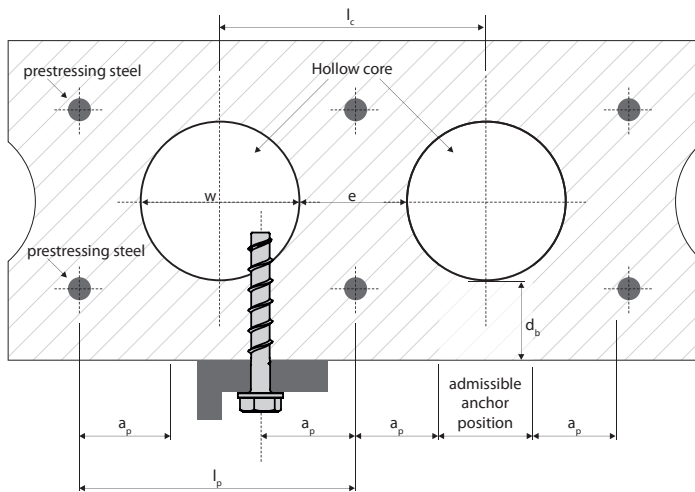

$w / e \leq 4,2$

- w Core width
- e Web thickness

- Core distance $l_c \geq 100$ mm
- Distance between prestressing steel $l_p \geq 100$ mm
- Distance between anchor position and pre-stressing steel $a_p \geq 50$ mm

Installation parameters for anchors in precast pre-stressed hollow core slabs

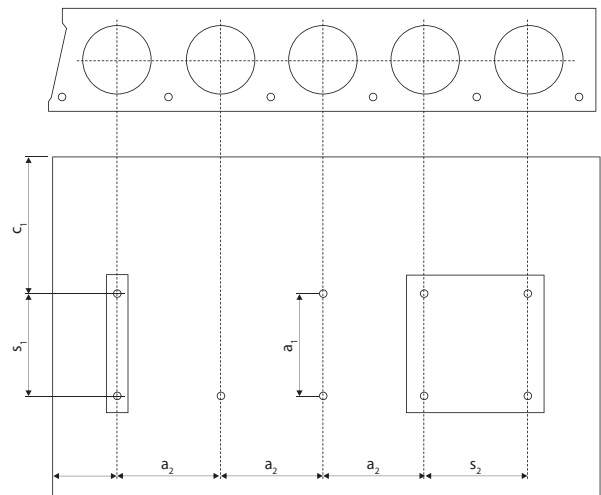

- c_1, c_2 Edge distance
- s_1, s_2 Anchor spacing
- a_1, a_2 Distance between the anchor groups

- Minimum edge distance $c_{min} \geq 100$ mm
- Minimum spacing $s_{min} \geq 100$ mm
- Minimum distance between the anchor groups $a_{min} \geq 100$ mm

Installation

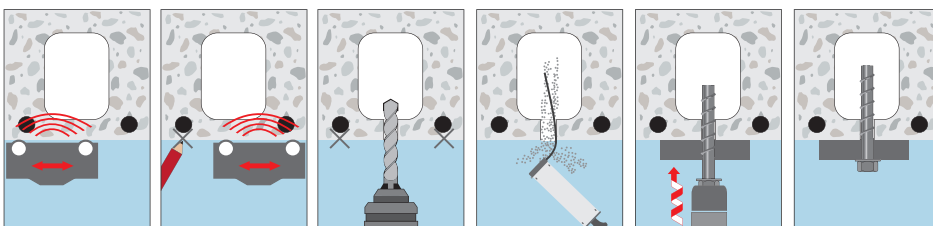

Concrete screw BSZ A4

Stainless steel A4

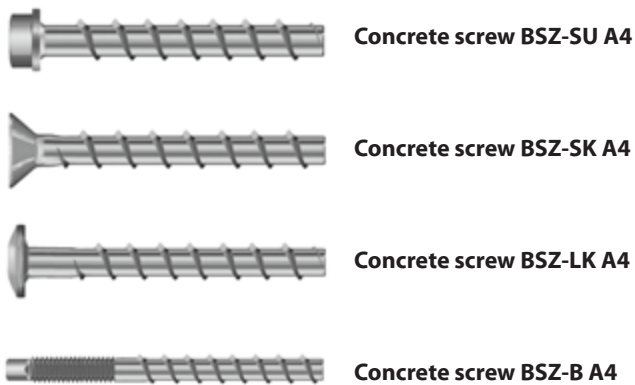

Range of loading: 0,4 kN - 19,4 kN
Range of concrete quality: C20/25 - C50/60

Description

Option 1 approved concrete screw BSZs cut a positive thread in the concrete when being screwed in and enable attachment to be made close to the edge through the expansion-free operating principle (=undercut). The approved adjustment enables subsequent alignment to compensate for unevenness. The BSZ A4 concrete screw is also ideal for temporary fixings since it is fully removable. Installation with an impact screwdriver means that you do not need to use a torque wrench. It is quick, reliable and reduces assembly errors.

The BSZ A4 concrete screws are available with connection thread and with a range of different head shapes for a wide variety of applications.

Advantages

- European Technical Assessment for anchoring in cracked and non-cracked concrete (Option 1) for concrete screws in sizes 6, 8 and 10
- With up to 3 embedment depths, it is versatile for high loads or low levels of drilling and installation effort
- European Technical Assessment for multiple use for non-structural systems in concrete and precast pre-stressed hollow core slabs for concrete screws in diameter 6
- Approved for use under seismic conditions of category C1 ($\varnothing 8$ to $\varnothing 10$ for embedment depth h_{nom} 3)
- Approved for use under fire exposure (R30-R120).
- Small drill hole diameter, small edge and axial gap
- Rapid push-through installation with an impact screwdriver without torque regulation
- No curing times, can be loaded immediately
- Adjustable to compensate for unevenness ($\varnothing 8$ - $\varnothing 10$ mm)
- Can be fully removed
- Wide range of possible applications through numerous variants
- Visually appealing through different head shapes
- Without approval, can also be used in compression-resistant natural stone, various solid bricks and green concrete

¹⁾Not for applications in precast pre-stressed hollow core slabs



Mechanical Heavy Duty Anchors

Approvals and Certificates

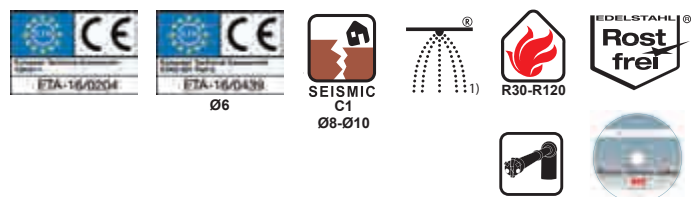

Applications

To anchor moderate to heavy loads outside and inside in cracked and non-cracked concrete: Railings and handrails, steel beams, wooden beams, supports and braces, brackets, pipeline and cable routes, suspended ceilings, etc.

Highly versatile for up to three different embedment depths:

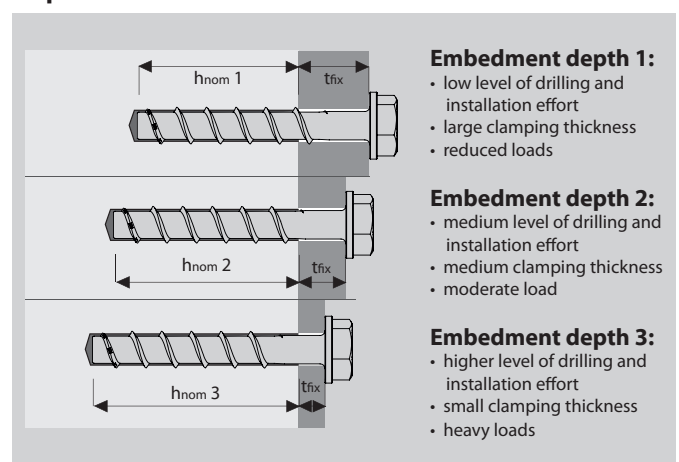

Concrete screw BSZ-SU A4



- Hex head with pressed disc
- Stainless Steel A4
- Through smaller drive and pressed on washer also suitable for areas where access is difficult and elongated holes

Description	Ref. No.	Embedment depth 1 ¹⁾			Embedment depth 2			Embedment depth 3			Seismic C1	Anchor length L	Pressed disk Ø	Drive	Pkg. content	Weight per pkg.
		Fixture thickness t _{fix}	Drill hole Ø x depth	Embedment depth h _{nom 1}	Fixture thickness t _{fix}	Drill hole Ø x depth	Embedment depth h _{nom 2}	Fixture thickness t _{fix}	Drill hole Ø x depth	Embedment depth h _{nom 3}						
		mm	mm	mm	mm	mm	mm	mm	mm	mm						
BSZ-SU 6x50 A4	59121001	15	6x40	35	10	6x45	40	-	-	-	-	50	17	SW 13	100	1,79
BSZ-SU 6x60 A4	59121501	25	6x40	35	20	6x45	40	5	6x60	55	-	60	17	SW 13	100	2,17
BSZ-SU 8x70 A4	59132001	25	8x55	45	15	8x65	55	5	8x75	65	✓	70	16	SW 13	50	2,05
BSZ-SU 8x80 A4	59132501	35	8x55	45	25	8x65	55	15	8x75	65	✓	80	16	SW 13	50	2,20
BSZ-SU 10x90 A4	59142501	35	10x65	55	15	10x85	75	5	10x95	85	✓	90	20	SW 15	50	3,82
BSZ-SU 10x100 A4	59143001	45	10x65	55	25	10x85	75	15	10x95	85	✓	100	20	SW 15	50	4,13
BSZ-SU 10x120 A4	59144001	65	10x65	55	45	10x85	75	35	10x95	85	✓	120	20	SW 15	50	4,73

¹⁾For embedment depth h_{nom 1} = 35 mm: Only for multiple use for non-structural systems in concrete and precast pre-stressed hollow core slabs.

Concrete screw BSZ-SK A4



- Countersunk head with Torx drive
- Stainless Steel A4
- For installations being flush with the fixture

Description	Ref. No.	Embedment depth 1 ¹⁾			Embedment depth 2			Embedment depth 3			Seismic C1	Anchor length L	Head-Ø	Drive	Pkg. content	Weight per pkg.
		Fixture thickness t _{fix}	Drill hole Ø x depth	Embedment depth h _{nom 1}	Fixture thickness t _{fix}	Drill hole Ø x depth	Embedment depth h _{nom 2}	Fixture thickness t _{fix}	Drill hole Ø x depth	Embedment depth h _{nom 3}						
		mm	mm	mm	mm	mm	mm	mm	mm	mm						
BSZ-SK 6x50 A4	59321501	15	6x40	35	10	6x45	40	-	-	-	-	50	13	T 30	100	1,30
BSZ-SK 6x65 A4	59322501	30	6x40	35	25	6x45	40	10	6x60	55	-	65	13	T 30	100	1,57
BSZ-SK 6x85 A4	59323501	50	6x40	35	45	6x45	40	30	6x60	55	-	85	13	T 30	100	2,05
BSZ-SK 6x105 A4	59324501	70	6x40	35	65	6x45	40	50	6x60	55	-	105	13	T 30	100	2,35
BSZ-SK 8x80 A4	59332501	35	8x55	45	25	8x65	55	15	8x75	65	✓	80	19,5	T 40	50	1,95
BSZ-SK 10x90 A4	59342501	35	10x65	55	15	10x85	75	5	10x95	85	✓	90	21,5	T 50	50	3,10

¹⁾For embedment depth h_{nom 1} = 35 mm: Only for multiple use for non-structural systems in concrete and precast pre-stressed hollow core slabs.

Concrete screw BSZ-LK A4



- Pan head with Torx drive
- Stainless Steel A4
- For a flat fixing which has a high-quality look

Description	Ref. No.	Embedment depth 1 ¹⁾			Embedment depth 2			Embedment depth 3			Seismic C1	Anchor length L	Head-Ø	Drive	Pkg. content	Weight per pkg.
		Fixture thickness t _{fix}	Drill hole Ø x depth	Embedment depth h _{nom 1}	Fixture thickness t _{fix}	Drill hole Ø x depth	Embedment depth h _{nom 2}	Fixture thickness t _{fix}	Drill hole Ø x depth	Embedment depth h _{nom 3}						
		mm	mm	mm	mm	mm	mm	mm	mm	mm						
BSZ-LK 6x50 A4	59421501	15	6x40	35	10	6x45	40	-	-	-	-	50	15	T 30	100	1,45
BSZ-LK 6x60 A4	59422001	25	6x40	35	20	6x45	40	5	6x60	55	-	60	15	T 30	100	1,67
BSZ-LK 6x80 A4	59423001	45	6x40	35	40	6x45	40	25	6x60	55	-	80	15	T 30	100	2,08
BSZ-LK 6x100 A4	59424001	65	6x40	35	60	6x45	40	45	6x60	55	-	100	15	T 30	100	2,57

¹⁾For embedment depth h_{nom 1} = 35 mm: Only for multiple use for non-structural systems in concrete and precast pre-stressed hollow core slabs.

Concrete screw BSZ-B A4



- ➔ With metric connection thread and hex drive
- ➔ Stainless Steel A4
- ➔ For pre-setting and through-setting installation and for distance mounting

Description	Ref. No.	Embedment depth 1			Embedment depth 2			Embedment depth 3			Seismic C1	Anchor length L	Con-nection thread	Drive	Pkg. content	Weight per pkg.
		Fixture thickness t _{fix}	Drill hole Ø x depth	Embedment depth h _{nom.1}	Fixture thickness t _{fix}	Drill hole Ø x depth	Embedment depth h _{nom.2}	Fixture thickness t _{fix}	Drill hole Ø x depth	Embedment depth h _{nom.3}						
BSZ-B 8x105 A4	59834001	39	8x55	45	29	8x65	55	19	8x75	65	-	105	M10x30	SW 7	50	2,30
BSZ-B 10x140 A4	59845001	59	10x65	55	39	10x85	75	29	10x95	85	-	140	M12x35	SW 9	50	4,58
BSZ-B 10x160 A4	59846001	79	10x65	55	59	10x85	75	49	10x95	85	-	160	M12x55	SW 9	50	5,30

¹⁾For embedment depth h_{nom.1} = 35 mm: Only for multiple use for non-structural systems in concrete and precast pre-stressed hollow core slabs.

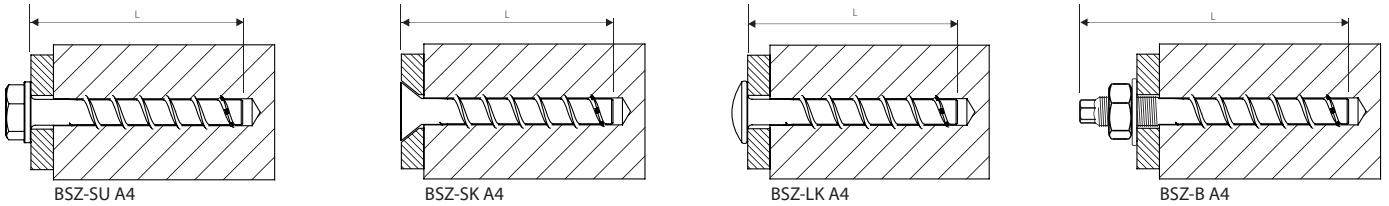

Recommended impact screwdriver

Description of concrete screw recommended impact screwdriver

- BSZ 6**
- Milwaukee C 12 IW (Square drive, Battery operation, max. torque 136 Nm)
 - Milwaukee C 12ID (Multi-toothed drive, Battery operation, max. torque 96 Nm)
 - DeWalt DEDC 840 KB (Square drive, Battery operation, max. torque 160 Nm)
 - Würth ASS 14 (1/4 inch drive, Battery operation, max. torque 150 Nm)
- BSZ 8
BSZ 10**
- Milwaukee C 18 IW (Square drive, Battery operation, max. torque 250 Nm)
 - Bosch GDS 18E (Square drive, Mains operation, max. torque 250 Nm)
 - Makita 6905H (Square drive, Mains operation, max. torque 300 Nm)
 - Würth ASS 18 (1/2 inch drive, Battery operation, max. torque 180 Nm)
 - Würth ESS (1/2 inch drive, Mains operation, max. torque 250 Nm)

Mechanical Heavy Duty Anchors

Notes for subsequent adjustment

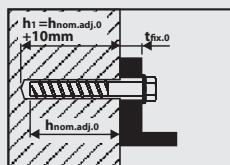

1. In order to be able to carry out subsequent adjustment, the concrete screw must be screwed at least 10mm deeper than the nominal embedment depth. This must be taken into account at the point when you are selecting the length of the concrete screw.

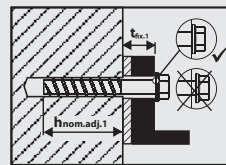

4. After fitting the lining, then re-mount the fixture in accordance with the installation instructions.

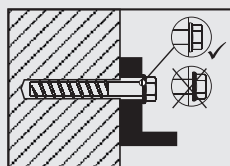

2. After successful installation, if relining is necessary for compensation, this is possible with the concrete screw BSZ (Ø 8 – 14 mm).

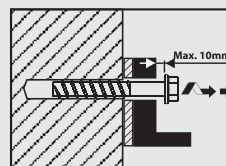

5. If the first lining is not sufficient then it is possible to repeat the adjustment. To do this, once again, the concrete screw must be turned back by a maximum of 10 mm so that another lining can be fitted.

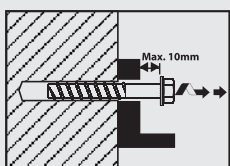

3. To do this, when the adjustment is carried out for the first time, the concrete screw must be turned back by a maximum of 10 mm.

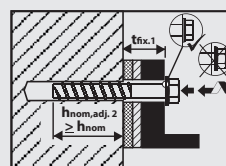

6. After the second lining, then re-mount the fixture in accordance with the installation instructions..

- The anchor can only be adjusted twice. When doing this the anchor can only be screwed back to a maximum of 10 mm.
- In total the lining which is a result of the adjustment must be a maximum of 10 mm.
- The required seating depth h_{nom} must be maintained after adjustment (h_{nom} = L - t_{fix}).



Extract from the application conditions of the European Technical Assessment ETA-16/0204

Approved loads for single anchor without influence of spacing and edge distance.

Total safety factor as per ETAG 001 included (γ_M and γ_F). Load capacities under fire exposure see page 168.

Loads and performance data		Concrete screw size		BSZ 6 A4		BSZ 8 A4			BSZ 10 A4		
Nominal embedment depth 1	$h_{nom 1}$	[mm]	-	-	45	-	-	55	-	-	
Nominal embedment depth 2	$h_{nom 2}$	[mm]	40	-	-	55	-	-	75	-	
Nominal embedment depth 3	$h_{nom 3}$	[mm]	-	55	-	-	65	-	-	85	
cracked concrete											
Approved loads, tension	C20/25	appr. N	[kN]	1,0	1,9	2,4	4,3	5,7	4,3	8,0	9,6
	C25/30	appr. N	[kN]	1,0	2,1	2,6	4,7	6,3	4,7	8,7	10,5
	C30/37	appr. N	[kN]	1,2	2,3	2,9	5,2	7,0	5,2	9,7	11,7
	C40/50	appr. N	[kN]	1,3	2,7	3,4	6,1	8,1	6,1	11,3	13,6
	C50/60	appr. N	[kN]	1,5	3,0	3,7	6,6	8,9	6,6	12,3	14,9
non-cracked concrete											
Approved loads, tension	C20/25	appr. N	[kN]	1,9	4,3	3,6	5,7	7,6	5,7	9,5	11,9
	C25/30	appr. N	[kN]	2,1	4,7	3,9	6,3	8,3	6,3	10,4	13,0
	C30/37	appr. N	[kN]	2,3	5,2	4,3	7,0	9,3	7,0	11,6	14,5
	C40/50	appr. N	[kN]	2,7	6,1	5,1	8,1	10,8	8,1	13,5	16,8
	C50/60	appr. N	[kN]	3,0	6,6	5,5	8,9	11,8	8,9	14,8	18,4
cracked / non-cracked concrete											
Approved loads, shear	C20/25	appr. V	[kN]	3,0/4,0	4,0/4,0	3,5/5,0	4,8/6,8	6,4/9,0	4,8/6,8	15,9/19,4	19,2/19,4
	\geq C25/30	appr. V	[kN]	3,2/4,0	4,0/4,0	3,9/5,5	5,3/7,4	7,0/9,7	5,3/7,4	17,5/19,4	19,4/19,4
Approved bending moments		appr. M	[Nm]	6,2	6,2	14,9	14,9	14,9	32,0	32,0	32,0
Spacing and edge distance											
Effective anchorage depth	h_{ef}	[mm]	31	44	35	43	52	43	60	68	
Characteristic spacing	$s_{cr, N}$	[mm]	93	132	105	129	156	129	180	204	
Characteristic edge distance	$c_{cr, N}$	[mm]	46,5	66	52,5	64,5	78	64,5	90	102	
Minimum thickness of concrete slab	h_{min}	[mm]	100	100	100	100	120	100	130	130	
Minimum spacing	s_{min}	[mm]	40	40	40	50	50	50	50	50	
Minimum edge distance	c_{min}	[mm]	40	40	40	50	50	50	50	50	
Installation parameters											
Drill hole diameter	d_o	[mm]	6	6	8	8	8	10	10	10	
Diameter of clearance hole in the fixture	$d_{r \leq}$	[mm]	8	8	12	12	12	14	14	14	
Depth of drill hole	$h_1 \geq$	[mm]	45	60	55	65	75	65	85	95	
Installation torque for metric connection thread	$T_{inst \leq}$	[Nm]	10	10	20	20	20	40	40	40	
Tangential impact screwdriver ¹⁾	$T_{imp, max}$	[Nm]	160	160	300	300	300	400	400	400	

¹⁾It is possible to fit with a tangential screwdriver with maximum output of $T_{imp, max}$ in accordance with the manufacturer's specifications

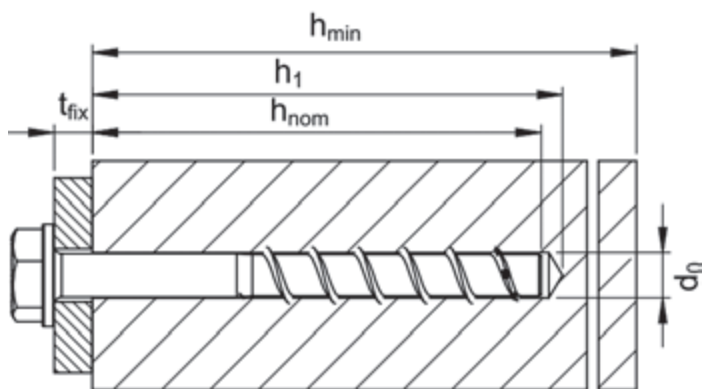

Installation

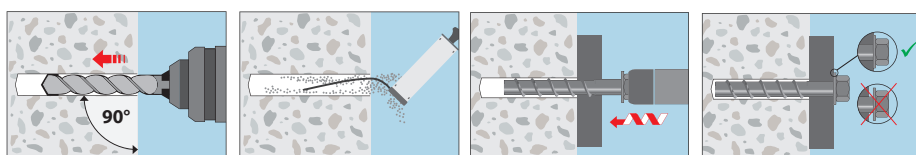



Extract from Permissible Service Conditions of European Technical Assessment ETA-16/0439

Multiple use for non-structural applications. Total safety factor as per ETAG 001 included (γ_M and γ_P). Depending on national regulations, the maximum allowable load per fixing point may be lower than the approved load of the anchor. The allowable loads per fixing point are regulated for the particular countries in the ETAG 001, Part 6.

Loads and performance data	Concrete screw size	BSZ 6 A4		
Nominal embedment depth 1	$h_{nom 1}$	[mm]	35	-
Nominal embedment depth 2	$h_{nom 2}$	[mm]	-	-
Nominal embedment depth 3	$h_{nom 3}$	[mm]	-	55
cracked concrete				
Approved loads, tension	C20/25	appr. N	[kN]	0,6 3,6
	C25/30	appr. N	[kN]	0,7 3,9
	C30/37	appr. N	[kN]	0,7 4,3
	C40/50	appr. N	[kN]	0,8 5,1
	C50/60	appr. N	[kN]	0,9 5,5
non-cracked concrete				
Approved loads, tension	C20/25	appr. N	[kN]	0,6 3,6
	C25/30	appr. N	[kN]	0,7 3,9
	C30/37	appr. N	[kN]	0,7 4,3
	C40/50	appr. N	[kN]	0,8 5,1
	C50/60	appr. N	[kN]	0,9 5,5
cracked / non-cracked concrete				
Approved loads, shear	C20/25	appr. V	[kN]	2,0/2,8 4,0/4,0
	\geq C25/30	appr. V	[kN]	2,2/3,1 4,0/4,0
Approved bending moments		appr. M	[Nm]	6,2 6,2

Spacing and edge distance				
Effective anchorage depth	h_{ef}	[mm]	27	44
Characteristic spacing	$s_{cr, N}$	[mm]	81	132
Characteristic edge distance	$c_{cr, N}$	[mm]	40,5	66
Minimum thickness of concrete slab	h_{min}	[mm]	80	100
Minimum spacing	s_{min}	[mm]	35	40
Minimum edge distance	c_{min}	[mm]	35	40

Installation parameters				
Drill hole diameter	d_o	[mm]	6	6
Diameter of clearance hole in the fixture	d_f	[mm]	8	8
Depth of drill hole	$h_{1 \geq}$	[mm]	40	60
Installation torque for metric connection thread	$T_{inst \leq}$	[Nm]	10	10
Tangential impact screwdriver ¹⁾	$T_{imp, max}$	[Nm]	160	160

¹⁾It is possible to fit with a tangential screwdriver with maximum output of $T_{imp, max}$ in accordance with the manufacturer's specifications

Approved loads with exposure to fire				
in cracked and non-cracked concrete C20/25 to C50/60				
Approved loads, tension	R30	appr. N_{fi}	[kN]	0,38 1,2
	R60	appr. N_{fi}	[kN]	0,38 1,2
	R90	appr. N_{fi}	[kN]	0,38 1,2
	R120	appr. N_{fi}	[kN]	0,30 0,8
Approved loads, shear	R30	appr. V_{fi}	[kN]	0,68 1,2
	R60	appr. V_{fi}	[kN]	0,68 1,2
	R90	appr. V_{fi}	[kN]	0,68 1,2
	R120	appr. V_{fi}	[kN]	0,55 0,8
Characteristic spacing	$s_{cr, fi}$	[mm]	108	176
Characteristic edge distance	$c_{cr, fi}$	[mm]	54	88



Extract from Permissible Service Conditions of European Technical Assessment ETA-16/0439

Multiple use for non-structural applications. Total safety factor as per ETAG 001 included (γ_M and γ_F). Depending on national regulations, the maximum allowable load per fixing point may be lower than the approved load of the anchor. The allowable loads per fixing point are regulated for the particular countries in the ETAG 001, Part 6.

Loads and performance data		Concrete screw size		BSZ 6 A4	
Nominal embedment depth	h_{nom}	[mm]	≥ 35		
Precast pre-stressed hollow core slabs C30/37 to C50/60					
Flange thickness	$d_b \geq$	[mm]	25	30	35
	F_{appr}	[kN]	0,4	0,8	1,2
Spacing and edge distance					
Minimum spacing	s_{min}	[mm]	100		
Minimum edge distance	c_{min}	[mm]	100		
Installation parameters					
Drill hole diameter	d_o	[mm]	6		
Diameter of clearance hole in the fixture	d_f	[mm]	8		
Depth of drill hole	$h_{1\geq}$	[mm]	40		
Installation torque	$T_{inst \leq}$	[Nm]	10		

Installation in precast pre-stressed hollow core slabs

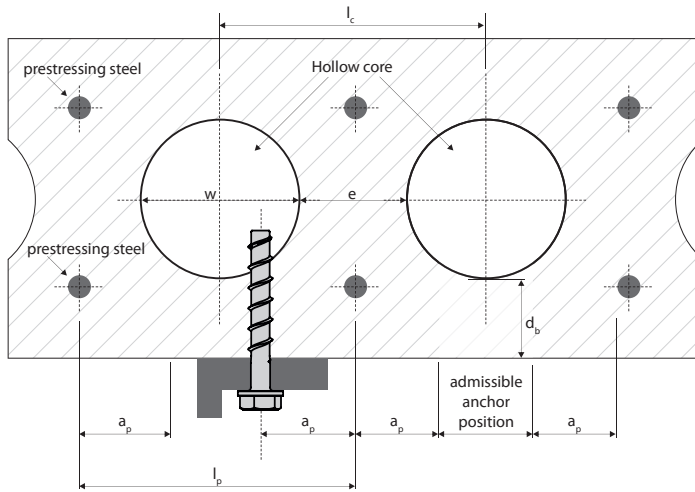

$w / e \leq 4,2$

- w Core width
- e Web thickness

- Core distance $l_c \geq 100$ mm
- Distance between prestressing steel $l_p \geq 100$ mm
- Distance between anchor position and pre-stressing steel $a_p \geq 50$ mm

Installation parameters for anchors in precast pre-stressed hollow core slabs

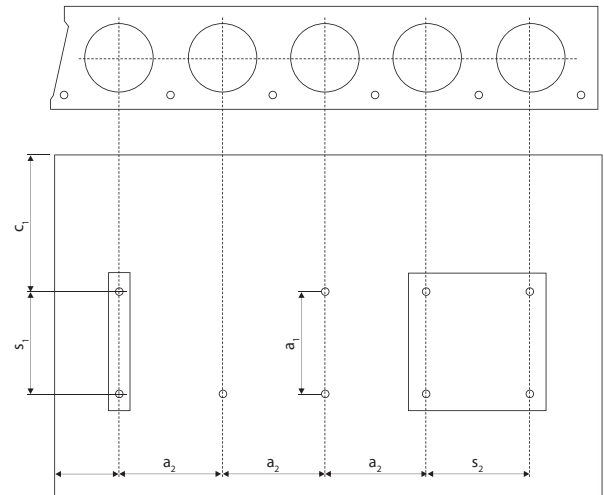

- c_1, c_2 Edge distance
- s_1, s_2 Anchor spacing
- a_1, a_2 Distance between the anchor groups

- Minimum edge distance $c_{min} \geq 100$ mm
- Minimum spacing $s_{min} \geq 100$ mm
- Minimum distance between the anchor groups $a_{min} \geq 100$ mm

Installation

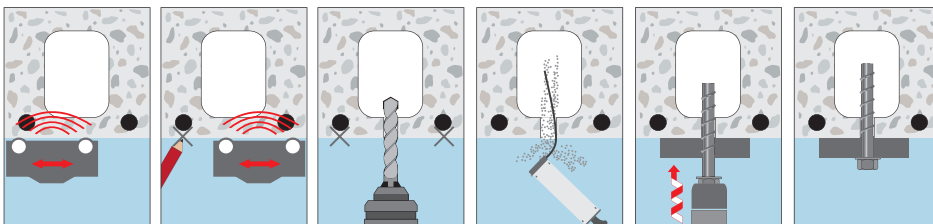

Chemical Anchors

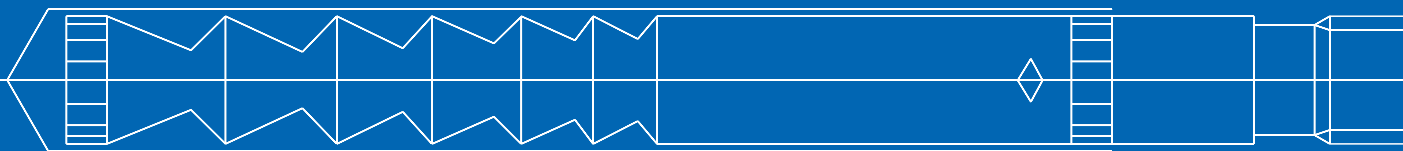

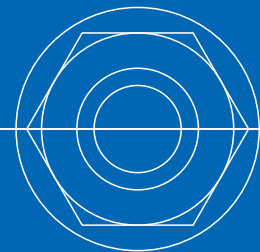
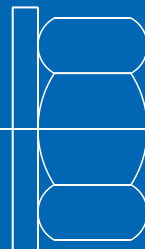
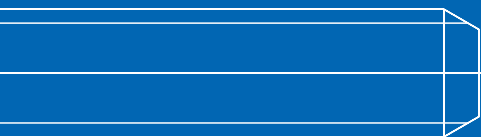

Injection System VMZ



Conical Stud VMZ-A



Cartridge VMZ 150
Coaxial Cartridge
for silicone guns
Content: 150ml



Cartridge VMZ 280
Coaxial Cartridge
for silicone guns
Content: 280ml, incl. 2 Static
mixer on Cartridge

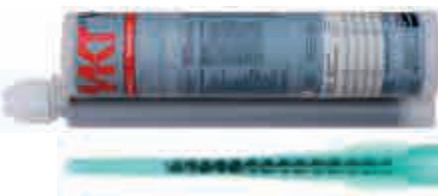

Cartridge VMZ 345
Side-by-side Cartridge
Content: 345ml



Cartridge VMZ 420
Coaxial Cartridge
Content: 420ml



**Cartridge VMZ 345
express**
Side-by-side Cartridge
Content: 345ml

Range of loading: 4,3 kN - 105,7 kN
Range of concrete quality: C20/25 - C50/60
Material: Steel, zinc plated, Stainless steel A4,
Stainless steel HCR
**on demand: hot dip galvanized
or sheradized**

Description

The Injection System VMZ consists of an anchor rod with conical expansion elements and a 2 component injection adhesive. This combination provides extremely high load bearing capacity even at minimum edge distance and spacing. The VMZ system combines the benefits of bonded anchors and expansion anchors in a European technical approved fastening system for both cracked and non-cracked concrete.



Advantages:

- Small thickness of concrete slab
- No load reduction for wet or water-filled drill holes (drill holes do=14mm and larger)
- Approved from -5 °C to +40°C temperature of base material while installing
- Approved to use under seismic action according to the performance category C1 and C2 (M10-M24)
- Through fastening installation possible for M10 and bigger (no additional accessories required)
- VMZ 75 M12: drill hole like M10 but connection thread M12 (ideally suited for through fastening installation)
- With fire test report
- Large variety of different diameters, anchorage depths and lengths
- Very economic fixings, optimized to the requirements of the fixing
- Opened cartridges can be re-used with a new mixer nozzle
- Tested according to ZTV tunnel temperature curve (M10-M24 HCR).

Applications:

Heavy duty fastenings in cracked and non-cracked concrete, e.g. steel beams, steel supports, railings, brackets, facade substructures, cable trays, fixing of bridge railings according to GEL 14 (VMZ 75 M12-40/135 A4) and GEL 33 (VMZ 90 M16-60/175 A4).

Injection Cartridge VMZ



- Two component cartridge, styrene-free
- Various cartridge systems
- Approved for cracked and non-cracked concrete

Description	Ref. No.	Content ml	Content of master box pcs.	Weight per master box kg	Weight per piece kg
Cartridge VMZ 150	28999301	150	12	4,32	0,36
Cartridge VMZ 280 ¹⁾	28252601	280	12	6,70	0,56
Cartridge VMZ 345	28255310	345	12	8,28	0,69
Cartridge VMZ 420	28254701	420	12	9,84	0,83
Cartridge VMZ 345 express	28254201	345	12	8,00	0,65
Static mixer VM-X (for all cartridge)	28305111	-	12	0,12	0,01
Mixer extension VM-XE 10/200 (200mm)	28306011	-	12	-	0,01
Mixer extension VM-XE 10/500 (500mm)	85951101	-	10	0,02	-
Installation wedge VMZ-MK	33300103	-	10	-	0,01

One static mixer as well as one screw-on cap comes with each cartridge. Usable length of static mixer see page 84.

¹⁾Cartridge VMZ 280 comes with 2 mixers.

Conical Stud VMZ-A

Steel, zinc plated



→ For use in structures subject to dry internal conditions

→ Version LG: with thread to concrete surface

→ Drill hole depth from 42mm

Description	Ref. No.	Drill hole Ø x depth mm	Setting depth mm	Seismic C1 / C2	Fixture thickness mm	Anchor length mm	Thread mm	Pkg. cont. pcs.	Weight per pkg. kg
VMZ-A 40 M8-15/65	32115101	10x42	41	- / -	15	65	M8x22	10	0,30
VMZ-A 50 M8-15/80	32120101	10x55	52	- / -	15	80	M8x22	10	0,36
VMZ-A 50 M8-30/95	32135101	10x55	52	- / -	30	95	M8x31	10	0,41
VMZ-A 50 M8-45/110	32145101	10x55	52	- / -	45	110	M8x31	10	0,47
VMZ-A 60 M10-10/85	32205101	12x65	63	✓ / ✓	10	85	M10x18	10	0,61
VMZ-A 60 M10-20/95	32220101	12x65	63	✓ / ✓	20	95	M10x27	10	0,66
VMZ-A 60 M10-30/105	32225101	12x65	63	✓ / ✓	30	105	M10x27	10	0,72
VMZ-A 60 M10-60/135	32235101	12x65	63	✓ / ✓	60	135	M10x47	10	0,87
VMZ-A 60 M10-100/175	32245101	12x65	63	✓ / ✓	100	175	M10x57	10	1,10
VMZ-A 75 M10-20/110	32255101	12x80	78	✓ / ✓	20	110	M10x27	10	0,75
VMZ-A 75 M12-25/120	32323171	12x80	78	✓ / ✓	25	120	M12x37	10	0,85
VMZ-A 75 M12-40/135	32324171	12x80	78	✓ / ✓	40	135	M12x52	10	0,95
VMZ-A 75 M12-60/155	32333101	12x80	78	✓ / ✓	60	155	M12x72	10	1,05
VMZ-A 75 M12-80/175	32336101	12x80	78	✓ / ✓	80	175	M12x87	10	1,20
VMZ-A 70 M12-25/115	32323101	14x75	74	✓ / ✓	25	115	M12x36	10	1,20
VMZ-A 80 M12-10/110	32305101	14x85	84	✓ / ✓	10	110	M12x21	10	1,17
VMZ-A 80 M12-25/125	32325101	14x85	84	✓ / ✓	25	125	M12x36	10	1,28
VMZ-A 80 M12-50/150	32330101	14x85	84	✓ / ✓	50	150	M12x46	10	1,49
VMZ-A 80 M12-100/200	32345101	14x85	84	✓ / ✓	100	200	M12x71	10	1,93
VMZ-A 80 M12-125/225	32355101	14x85	84	✓ / ✓	125	225	M12x71	10	2,17
VMZ-A 80 M12-165/265	32365101	14x85	84	✓ / ✓	165	265	M12x71	10	2,57
VMZ-A 95 M12-25/140	32327101	14x100	99	✓ / ✓	25	140	M12x36	10	1,40
VMZ-A 100 M12-25/145	32375101	14x105	104	✓ / ✓	25	145	M12x36	10	1,46
VMZ-A 100 M12-60/180	32385101	14x105	104	✓ / ✓	60	180	M12x56	10	1,75
VMZ-A 100 M12-100/220	32390101	14x105	104	✓ / ✓	100	220	M12x84	10	2,12
VMZ-A 110 M12-25/155	32377101	14x115	114	✓ / ✓	25	155	M12x36	10	1,55
VMZ-A 125 M12-25/170	32379101	14x130	129	✓ / ✓	25	170	M12x36	10	1,75
VMZ-A 90 M16-30/145	32555101	18 x 98	94	✓ / ✓	30	145	M16x44	10	2,20
VMZ-A 105 M16-30/160	32550101	18x113	109	✓ / ✓	30	160	M16x44	10	2,45
VMZ-A 125 M16-30/180	32515101	18x133	130	✓ / ✓	30	180	M16x44	10	2,78
VMZ-A 125 M16-60/210	32520101	18x133	130	✓ / ✓	60	210	M16x55	10	3,60
VMZ-A 125 M16-100/250	32530101	18x133	130	✓ / ✓	100	250	M16x65	10	4,23
VMZ-A 125 M16-165/315	32540101	18x133	130	✓ / ✓	165	315	M16x90	10	5,25
VMZ-A 145 M16-30/200	32560101	18x153	150	✓ / ✓	30	200	M16x44	10	3,70
VMZ-A 160 M16-30/215	32502101	18x168	165	✓ / ✓	30	215	M16x44	10	3,54
VMZ-A 160 M16-60/245	32504101	18x168	165	✓ / ✓	60	245	M16x55	10	3,98
VMZ-A 160 M16-100/285	32506101	18x168	165	✓ / ✓	100	285	M16x65	10	4,62
VMZ-A 115 M20-30/175	32608101	22x120	120	✓ / ✓	30	175	M20x46	5	2,40
VMZ-A 170 M20-20/225 LG	32603101	24x180	180	✓ / ✓	20	225	M20x41	5	3,40
VMZ-A 170 M20-25/230	32605101	24x180	180	✓ / ✓	25	230	M20x33	5	3,52
VMZ-A 170 M20-50/255	32610101	24x180	180	✓ / ✓	50	255	M20x46	5	3,83
VMZ-A 170 M20-100/305	32620101	24x180	180	✓ / ✓	100	305	M20x71	5	4,46
VMZ-A 190 M20-50/275	32612101	24x200	200	✓ / ✓	50	275	M20x46	5	4,20
VMZ-A 170 M24-50/260	32705101	26x185	182	✓ / ✓	50	260	M24x50	5	4,58
VMZ-A 170 M24-100/310	32715101	26x185	182	✓ / ✓	100	310	M24x75	5	5,46
VMZ-A 200 M24-50/290 LG	32711101	26x215	212	✓ / ✓	50	290	M24x75	5	5,11
VMZ-A 200 M24-50/290	32710101	26x215	212	✓ / ✓	50	290	M24x50	5	5,11
VMZ-A 200 M24-100/340	32720101	26x215	212	✓ / ✓	100	340	M24x75	5	6,01
VMZ-A 225 M24-50/315	32712101	26x240	237	✓ / ✓	50	315	M24x50	5	5,73

Other lengths or threads on demand.

Dispenser and accessories for drill hole cleaning see page 84/85.

Conical Stud VMZ-A A4

Stainless steel A4 / 316



→ For use in structures subject to dry internal conditions or external atmospheric exposure

→ Version LG: with thread to concrete surface

→ Drill hole depth from 42mm

Description	Ref. No.	Drill hole Ø x depth mm	Setting depth mm	Seismic C1 / C2	Fixture thickness mm	Anchor length mm	Thread mm	Pkg. cont. pcs.	Weight per pkg. kg
VMZ-A 40 M8-15/65 A4	32115501	10x42	41	- / -	15	65	M8x22	10	0,30
VMZ-A 50 M8-15/80 A4	32120501	10x55	52	- / -	15	80	M8x22	10	0,36
VMZ-A 50 M8-30/95 A4	32135501	10x55	52	- / -	30	95	M8x31	10	0,41
VMZ-A 50 M8-45/110 A4	32145501	10x55	52	- / -	45	110	M8x31	10	0,47
VMZ-A 60 M10-10/85 A4	32205501	12x65	63	✓ / ✓	10	85	M10x18	10	0,61
VMZ-A 60 M10-20/95 A4	32220501	12x65	63	✓ / ✓	20	95	M10x27	10	0,66
VMZ-A 60 M10-30/105 A4	32225501	12x65	63	✓ / ✓	30	105	M10x27	10	0,72
VMZ-A 60 M10-60/135 A4	32235501	12x65	63	✓ / ✓	60	135	M10x47	10	0,87
VMZ-A 60 M10-100/175 A4	32245501	12x65	63	✓ / ✓	100	175	M10x57	10	1,10
VMZ-A 75 M10-20/110 A4	32255501	12x80	78	✓ / ✓	20	110	M10x27	10	0,75
VMZ-A 75 M10-40/130 A4	32265501	12x80	78	✓ / ✓	40	130	M10x47	10	0,86
VMZ-A 75 M12-25/120 A4	32323571	12x80	78	✓ / ✓	25	120	M12x37	10	0,85
VMZ-A 75 M12-40/135 A4	32324571	12x80	78	✓ / ✓	40	135	M12x52	10	0,95
VMZ-A 75 M12-60/155 A4	32333501	12x80	78	✓ / ✓	60	155	M12x72	10	1,05
VMZ-A 75 M12-80/175 A4	32336501	12x80	78	✓ / ✓	80	175	M12x92	10	1,20
VMZ-A 70 M12-25/115 A4	32323501	14x75	74	✓ / ✓	25	115	M12x36	10	1,20
VMZ-A 70 M12-40/130 A4	32324501	14x75	74	✓ / ✓	40	130	M12x36	10	1,33
VMZ-A 80 M12-10/110 A4	32305501	14x85	84	✓ / ✓	10	110	M12x21	10	1,17
VMZ-A 80 M12-25/125 A4	32325501	14x85	84	✓ / ✓	25	125	M12x36	10	1,28
VMZ-A 80 M12-50/150 A4	32330501	14x85	84	✓ / ✓	50	150	M12x46	10	1,49
VMZ-A 80 M12-100/200 A4	32345501	14x85	84	✓ / ✓	100	200	M12x71	10	1,93
VMZ-A 80 M12-125/225 A4	32355501	14x85	84	✓ / ✓	125	225	M12x71	10	2,17
VMZ-A 80 M12-165/265 A4	32365501	14x85	84	✓ / ✓	165	265	M12x71	10	2,57
VMZ-A 95 M12-25/140 A4	32327501	14x100	99	✓ / ✓	25	140	M12x36	10	1,40
VMZ-A 100 M12-25/145 A4	32375501	14x105	104	✓ / ✓	25	145	M12x36	10	1,46
VMZ-A 100 M12-60/180 A4	32385501	14x105	104	✓ / ✓	60	180	M12x56	10	1,75
VMZ-A 100 M12-100/220 A4	32390501	14x105	104	✓ / ✓	100	220	M12x84	10	2,12
VMZ-A 110 M12-25/155 A4	32377501	14x115	114	✓ / ✓	25	155	M12x36	10	1,55
VMZ-A 125 M12-25/170 A4	32379501	14x130	129	✓ / ✓	25	170	M12x36	10	1,75
VMZ-A 90 M16-30/145 A4	32555501	18x98	94	✓ / ✓	30	145	M16x44	10	2,20
VMZ-A 90 M16-45/160 A4	32558501	18x98	94	✓ / ✓	45	160	M16x59	10	2,78
VMZ-A 90 M16-60/175 A4	32559501	18 x 98	94	✓ / ✓	60	175	M16x74	10	3,08
VMZ-A 105 M16-30/160 A4	32550501	18x113	109	✓ / ✓	30	160	M16x44	10	2,45
VMZ-A 125 M16-30/180 A4	32515501	18x133	130	✓ / ✓	30	180	M16x44	10	2,78
VMZ-A 125 M16-60/210 A4	32520501	18x133	130	✓ / ✓	60	210	M16x55	10	3,60
VMZ-A 125 M16-100/250 A4	32530501	18x133	130	✓ / ✓	100	250	M16x65	10	4,23
VMZ-A 125 M16-165/315 A4	32540501	18x133	130	✓ / ✓	165	315	M16x90	10	5,25
VMZ-A 145 M16-30/200 A4	32560501	18x153	150	✓ / ✓	30	200	M16x44	10	3,70
VMZ-A 160 M16-30/215 A4	32502501	18x168	165	✓ / ✓	30	215	M16x44	10	3,54
VMZ-A 160 M16-60/245 A4	32504501	18x168	165	✓ / ✓	60	245	M16x55	10	3,98
VMZ-A 160 M16-100/285 A4	32506501	18x168	165	✓ / ✓	100	285	M16x65	10	4,62
VMZ-A 115 M20-30/175 A4	32608501	22x120	120	✓ / ✓	30	175	M20x46	5	2,40
VMZ-A 170 M20-20/225 LG A4	32603501	24x180	180	✓ / ✓	20	225	M20x41	5	3,40
VMZ-A 170 M20-25/230 A4	32605501	24x180	180	✓ / ✓	25	230	M20x33	5	3,52
VMZ-A 170 M20-50/255 A4	32610501	24x180	180	✓ / ✓	50	255	M20x46	5	3,83
VMZ-A 170 M20-100/305 A4	32620501	24x180	180	✓ / ✓	100	305	M20x71	5	4,46
VMZ-A 190 M20-50/275 A4	32612501	24x200	200	✓ / ✓	50	275	M20x46	5	4,20
VMZ-A 170 M24-50/260 A4	32705501	26x185	182	✓ / ✓	50	260	M24x50	5	4,58
VMZ-A 170 M24-100/310 A4	32715501	26x185	182	✓ / ✓	100	310	M24x75	5	5,46
VMZ-A 200 M24-50/290 LG A4	32711501	26x215	212	✓ / ✓	50	290	M24x75	5	5,11
VMZ-A 200 M24-50/290 A4	32710501	26x215	212	✓ / ✓	50	290	M24x50	5	5,11
VMZ-A 200 M24-100/340 A4	32720501	26x215	212	✓ / ✓	100	340	M24x75	5	6,01
VMZ-A 225 M24-50/315 A4	32712501	26x240	237	✓ / ✓	50	315	M24x50	5	5,73

Other lengths or threads on demand.

Conical Stud VMZ-A HCR

Stainless steel HCR



→ For use in particularly corrosive environments

→ High Corrosion Resistant Steel grade 1.4529

→ Version LG: with thread to concrete surface

Description	Ref. No.	Drill hole Ø x depth mm	Setting depth mm	Seismic C1 / C2	Fixture thickness mm	Anchor length mm	Thread mm	Pkg. cont. pcs.	Weight per pkg. kg
VMZ-A 40 M8-15/65 HCR	32115651	10x42	41	- / -	15	65	M8x22	10	0,30
VMZ-A 50 M8-15/80 HCR	32120651	10x55	52	- / -	15	80	M8x22	10	0,36
VMZ-A 50 M8-30/95 HCR	32135651	10x55	52	- / -	30	95	M8x31	10	0,41
VMZ-A 50 M8-45/110 HCR	32145651	10x55	52	- / -	45	110	M8x31	10	0,47
VMZ-A 60 M10-10/85 HCR	32205651	12x65	63	✓ / ✓	10	85	M10x18	10	0,61
VMZ-A 60 M10-20/95 HCR	32220651	12x65	63	✓ / ✓	20	95	M10x27	10	0,66
VMZ-A 60 M10-30/105 HCR	32225651	12x65	63	✓ / ✓	30	105	M10x27	10	0,72
VMZ-A 60 M10-60/135 HCR	32235651	12x65	63	✓ / ✓	60	135	M10x47	10	0,87
VMZ-A 60 M10-100/175 HCR	32245651	12x65	63	✓ / ✓	100	175	M10x57	10	1,10
VMZ-A 75 M10-20/110 HCR	32255651	12x80	78	✓ / ✓	20	110	M10x27	10	0,75
VMZ-A 75 M12-25/120 HCR	32323671	12x80	78	✓ / ✓	25	120	M12x37	10	0,85
VMZ-A 70 M12-25/115 HCR	32323651	14x75	74	✓ / ✓	25	115	M12x36	10	1,20
VMZ-A 80 M12-10/110 HCR	32305651	14x85	84	✓ / ✓	10	110	M12x21	10	1,17
VMZ-A 80 M12-25/125 HCR	32325651	14x85	84	✓ / ✓	25	125	M12x36	10	1,28
VMZ-A 80 M12-50/150 HCR	32330651	14x85	84	✓ / ✓	50	150	M12x46	10	1,49
VMZ-A 80 M12-100/200 HCR	32345651	14x85	84	✓ / ✓	100	200	M12x71	10	1,93
VMZ-A 80 M12-125/225 HCR	32355651	14x85	84	✓ / ✓	125	225	M12x71	10	2,17
VMZ-A 80 M12-165/265 HCR	32365651	14x85	84	✓ / ✓	165	265	M12x71	10	2,57
VMZ-A 95 M12-25/140 HCR	32327651	14x100	99	✓ / ✓	25	140	M12x36	10	1,40
VMZ-A 100 M12-25/145 HCR	32375651	14x105	104	✓ / ✓	25	145	M12x36	10	1,46
VMZ-A 100 M12-60/180 HCR	32385651	14x105	104	✓ / ✓	60	180	M12x56	10	1,75
VMZ-A 100 M12-100/220 HCR	32390651	14x105	104	✓ / ✓	100	220	M12x84	10	2,12
VMZ-A 110 M12-25/155 HCR	32377651	14x115	114	✓ / ✓	25	155	M12x36	10	1,55
VMZ-A 125 M12-25/170 HCR	32379651	14x130	129	✓ / ✓	25	170	M12x36	10	1,75
VMZ-A 90 M16-30/145 HCR	32555651	18x98	94	✓ / ✓	30	145	M16x44	10	2,20
VMZ-A 105 M16-30/160 HCR	32550651	18x113	109	✓ / ✓	30	160	M16x44	10	2,45
VMZ-A 125 M16-30/180 HCR	32515651	18x133	130	✓ / ✓	30	180	M16x44	10	2,78
VMZ-A 125 M16-60/210 HCR	32520651	18x133	130	✓ / ✓	60	210	M16x55	10	3,60
VMZ-A 125 M16-100/250 HCR	32530651	18x133	130	✓ / ✓	100	250	M16x65	10	4,23
VMZ-A 125 M16-165/315 HCR	32540651	18x133	130	✓ / ✓	165	315	M16x90	10	5,25
VMZ-A 145 M16-30/200 HCR	32560651	18x153	150	✓ / ✓	30	200	M16x44	10	3,70
VMZ-A 160 M16-30/215 HCR	32502651	18x168	165	✓ / ✓	30	215	M16x44	10	3,54
VMZ-A 115 M20-30/175 HCR	32608651	22x120	120	✓ / ✓	30	175	M20x46	5	2,40
VMZ-A 170 M20-20/225 LG HCR	32603651	24x180	180	✓ / ✓	20	225	M20x41	5	3,40
VMZ-A 170 M20-25/230 HCR	32605651	24x180	180	✓ / ✓	25	230	M20x33	5	3,52
VMZ-A 170 M20-50/255 HCR	32610651	24x180	180	✓ / ✓	50	255	M20x46	5	3,83
VMZ-A 170 M20-100/305 HCR	32620651	24x180	180	✓ / ✓	100	305	M20x71	5	4,46
VMZ-A 190 M20-50/275 HCR	32612651	24x200	200	✓ / ✓	50	275	M20x46	5	4,20
VMZ-A 170 M24-50/260 HCR	32705651	26x185	182	✓ / ✓	50	260	M24x50	5	4,58
VMZ-A 200 M24-50/290 LG HCR	32705651	26x215	215	✓ / ✓	50	290	M24x75	5	5,11
VMZ-A 200 M24-50/290 HCR	32710651	26x215	215	✓ / ✓	50	290	M24x50	5	5,11
VMZ-A 200 M24-100/340 HCR	32720651	26x215	215	✓ / ✓	100	340	M24x75	5	6,01
VMZ-A 225 M24-50/315 HCR	32712651	26x240	237	✓ / ✓	50	315	M24x50	5	5,73

Other lengths or threads on demand.

Usable length Static mixer VM-X

Drill holes must always be filled from the bottom of the hole to ensure no air pockets are trapped in the adhesive. This is only possible when the tip of the mixing nozzle reaches the very bottom of the drill hole before injecting the adhesive. If the mixing nozzle does not reach the bottom of the drill hole, a mixer extension tube must be used.

Outer diameter mixer:

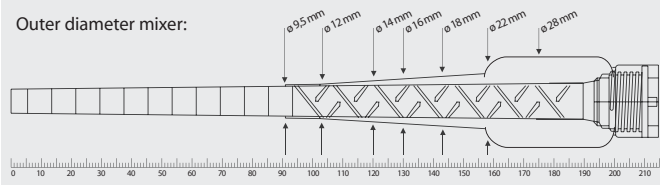

Curing Time Injection Adhesive VMZ

→ Cartridge temperature when installing min. +5°C

Temperature (°C) of the base material	Gel time	Curing time	
		dry base material	wet base material
-5°C	1:30 h	6:00 h	12:00 h ¹⁾
-4°C to -1°C	45 min	6:00 h	12:00 h ¹⁾
0°C to +4°C	20 min	3:00 h	6:00 h
+5°C to +9°C	12 min	2:00 h	4:00 h
+10°C to +19°C	6 min	1:20 h	2:40 h
+20°C to +29°C	4 min	45 min	1:30 h
+30°C to +34°C	2 min	25 min	50 min
+35°C to +39°C	1,4 min	20 min	40 min
+40°C	1,4 min	15 min	30 min

¹⁾It must be ensured that icing does not occur in the drill hole. The hole must be drilled and cleaned directly prior to the installation of the anchor.

Curing Time Injection Adhesive VMZ express

→ Cartridge temperature when installing min. +5°C

Temperature (°C) of the base material	Gel time	Curing time	
		dry base material	wet base material
-5°C	40 min	4:00 h	8:00 h ¹⁾
-4°C to -1°C	20 min	4:00 h	8:00 h ¹⁾
0°C to +4°C	10 min	2:00 h	4:00 h
+5°C to +9°C	6 min	1:00 h	2:00 h
+10°C to +19°C	3 min	40 min	80 min
+20°C to +29°C	1 min	20 min	40 min
+30°C	1 min	10 min	20 min

¹⁾It must be ensured that icing does not occur in the drill hole. The hole must be drilled and cleaned directly prior to the installation of the anchor.

Cleaning Brush RB M6



RB M6, with connection thread M6



RBL M6, with internal and external thread M6



RBL M6 SDS, with internal thread M6

- With connection thread M6 – extension for large depths of drill hole and/or for through-setting installation
- For drilling machines with keyed chuck or with SDS adaptor for SDS plus drill holder

Description	Ref. No.	Suitable for drill hole Ø mm	Total length of brush mm	Suitable for			Pkg. cont. pcs.	Weight per piece kg
				VMZ-A	VMZ-A dyn	VMZ-IG		
RB 10 M6	33510101	10	130	M8	-	M6	1	0,05
RB 12 M6	33512101	12	140	M10, 75 M12	-	M8	1	0,05
RB 14 M6	33514101	14	180	M12	M12	M10	1	0,05
RB 18 M6	33518101	18	200	M16	M16	M12	1	0,05
RB 22 M6	33522101	22	220	115 M20	-	115 M16	1	0,05
RB 24 M6	33524101	24	250	M20	M20	M16	1	0,06
RB 26 M6	33526101	26	290	M24	-	M20	1	0,06
RBL M6	33968101	Brush extension 150mm with connection thread M6					1	0,09
RBL M6 SDS	33350101	SDS Plus adapter with internal thread M6					1	0,06

Blow-out pump VM-AP



- For approval-compliant air-cleaning of drill holes with a diameter up to 18 mm (VMZ)
- For best drill hole cleaning, the hose must reach the bottom of the drill hole

Description	Ref. No.	Hose Ø mm	For drill hole Ø mm	Max. drill hole depth ²⁾ mm	Pkg. cont. pcs.	Weight per piece kg
VM-AP 360, blow-out pump	33200101	8	8 ¹⁾ -20	330	1	0,27

¹⁾With extension tube Ø 6 x 100mm
²⁾For through fastening: Maximum drill hole depth through fixture

Air gun VM-ABP



→ For approval-compliant drill hole cleaning with compressed air for drill holes with a diameter larger than 6 mm

→ For best drill hole cleaning, the nozzle of the air gun must reach the bottom of the drill hole

NEW

Description	Ref. No.	Nozzle- ø mm	For drill hole Ø mm	Max. drill hole depth ¹⁾ mm	Pkg. cont. pcs.	Weight per piece kg
VM-ABP 200	33090101	5	6-20	240	1	0,55
VM-ABP 250	33100101	16	18-40	240	1	1,00
VM-ABP 500	33106101	16	18-40	480	1	1,30

¹⁾For through fastening: Maximum drill hole depth through fixture

Dispenser VM-P Profi



→ Professional dispenser with an ideal center of gravity for more comfortable working

→ Automatic pressure release for minimum adhesive overrun

Description	Ref. No.	Suitable for cartridge	Pkg. cont. pcs.	Weight per piece kg
VM-P 345 Profi	28350511	150ml, 280ml, 300ml, 345ml also suitable for silicone cartridges	1	1,00
VM-P 380 Profi	28351001	380ml, 410ml, 420ml	1	1,10

Dispenser VM-P Standard



→ For occasional use, metal version

→ Piston rod with adjusting screw

Description	Ref. No.	Suitable for cartridge	Pkg. cont. pcs.	Weight per piece kg
VM-P 345 Standard	28350505	150ml, 280ml, 300ml, 345ml also suitable for silicone cartridges	1	1,00
VM-P 380 Standard	28353005	380ml, 410ml, 420ml	1	1,15

Dispenser VM-P Pneumatic



→ Professional air tool with an optimum center of gravity and quick cartridge exchange

→ Automatic pressure release system reduces adhesive overrun to a minimum

→ Single-hand pressure regulation to adjust the piston speed

→ With compressed air connection nipple

Description	Ref. No.	Suitable for cartridge	press-out force kN	Weight ¹⁾ kg	Dimensions ¹⁾ L x B x H mm	Pkg. cont. pcs.	Weight per piece kg
VM-P 345 Pneumatic	28350601	280ml, 300ml, 345ml	max. working pressure 8bar, 40l/min	5,0	395 x 180 x 285	1	2,41
VM-P 380 Pneumatic	28352002	380ml, 410ml, 420ml	max. working pressure 8bar, 40l/min	3,95	375 x 180 x 285	1	2,00

Dispenser VM-P Akku



¹⁾with battery 18V/2,0 Ah

→ Professional, solid battery cartridge dispenser in a plastic case

→ Repeat function, for retrieving the last fill quantity

→ Stepless variable pressing speed

→ Overrun-quantity-stop by automatic return after release of the dispensing switch

Description	Ref. No.	Suitable for cartridge	press-out force kN	Weight ¹⁾ kg	Dimensions ¹⁾ L x B x H mm	Pkg. cont. pcs.	Weight per piece kg
VM-P 345 Akku	28350801	345ml	5,0	3,53	395 x 180 x 285	1	7,72
VM-P 380 Akku	28352601	380ml, 410ml, 420ml	3,95	3,62	375 x 180 x 285	1	7,80
Accessories (for all models)							
Replacement battery	28352411			18 V/2,0 Ah		1	1,00
Shoulder strap	28359991			adjustable		1	0,02



Extract from Permissible Service Conditions of European Technical Assessment ETA-04/0092

Approved loads (static or quasi-static) for single anchor without influence of spacing and edge distance for temperature range -40°C to +80°C⁵⁾ (Approved loads for temperature range -40°C to +120°C see ETA-04/0092). Total safety factor as per ETAG 001 included (γ_M and γ_P). Load capacities under fire exposure see page 168.

Loads and performance data **Injection System VMZ, steel zinc plated M8-M12**



		40 M8	50 M8	60 M10	75 M10	75 M12	70 M12	80 M12	95 M12	100 M12	110 M12	125 M12
cracked concrete												
Mean ultimate loads, tension	C25/30 N _{um}	[kN]	12,3	19,5	28,0	29,5	34,9	41,0	48,2	51,6	67,2	67,2
Mean ultimate loads, shear	C25/30 V _{um}	[kN]	14,6	14,6	23,2	23,2	33,7	33,7	33,7	33,7	33,7	33,7
Approved loads, tension	C20/25 appr. N	[kN]	4,3	6,1	8,0	11,1	11,1	10,0	12,3	15,9	17,1	19,8
	C25/30 appr. N	[kN]	4,8	6,6	8,7	11,9	12,2	11,0	13,4	17,4	18,8	21,7
	C30/37 appr. N	[kN]	5,3	7,4	9,7	11,9	13,5	12,2	14,9	19,3	20,9	24,1
	C40/50 appr. N	[kN]	6,1	8,6	11,3	11,9	15,7	14,2	17,3	22,4	24,2	27,1
	C50/60 appr. N	[kN]	6,7	8,6	11,9	11,9	16,7	15,6	19,0	24,6	26,6	27,1
non-cracked concrete												
Approved loads, tension	C20/25 appr. N	[kN]	4,3	8,5	11,2	11,9	15,6	14,1	17,2	19,0	24,0	23,8
	C25/30 appr. N	[kN]	4,7	8,6	11,9	11,9	16,7	15,4	18,9	20,9	26,3	26,1
	C30/37 appr. N	[kN]	5,2	8,6	11,9	11,9	16,7	17,1	20,9	23,2	27,1	27,1
	C40/50 appr. N	[kN]	6,1	8,6	11,9	11,9	16,7	19,9	24,3	25,7	27,1	27,1
	C50/60 appr. N	[kN]	6,6	8,6	11,9	11,9	16,7	21,8	25,7	25,7	27,1	27,1
cracked and non-cracked concrete												
Approved loads, shear	≥ C20/25 appr. V	[kN]	8,0	8,0	12,0	12,0	19,4	19,4	19,4	19,4	19,4	19,4
Approved loads, shear Type LG	≥ C20/25 appr. V	[kN]	8,0	8,0	12,0	12,0	19,4	19,4	19,4	19,4	19,4	19,4
Approved bending moments	appr. M	[Nm]	17,1	17,1	34,3	34,3	60,0	60,0	60,0	60,0	60,0	60,0
Spacing and edge distance												
Effective anchorage depth	h _{ef}	[mm]	40	50	60	75	75	70	80	95	100	110
Characteristic spacing	s _{cr,N}	[mm]	120	150	180	225	225	210	240	285	300	330
Characteristic edge distance	c _{cr,N}	[mm]	60	75	90	112,5	112,5	105	120	142,5	150	165
cracked concrete												
Minimum thickness of concrete slab	≥ h _{min}	[mm]	80	80	100	110	110	110	110	130	130	140
Minimum spacing	s _{min}	[mm]	40	40	40	40	50	55	40	40	50	50
Minimum edge distance	c _{min}	[mm]	40	40	40	40	50	55	50	50	50	50
non-cracked concrete												
Minimum thickness of concrete slab	≥ h _{min}	[mm]	80	80	100	110	110	110	110	130	130	140
Minimum spacing	s _{min}	[mm]	40	40	50	50	50	55	55	801)	801)	801)
Minimum edge distance	c _{min}	[mm]	40	40	50	50	50	55	55	551)	551)	551)
Installation parameters												
Drill hole diameter	d _o	[mm]	10	10	12	12	12	14	14	14	14	14
Diameter of clearance hole in the fixture Pre-installation	d _f	[mm]	9	9	12	12	14	14	14	14	14	14
Diameter of clearance hole in the fixture Through fastening ²⁾	d _f	[mm]	- ⁴⁾	- ⁴⁾	14	14	14	16	16	16	16	16
Depth of drill hole	h _o	[mm]	42	55	65	80	80	75	85	100	105	115
Installation torque	≤ T _{inst}	[Nm]	10	10	15	15	25	25	25	30	30	30
Width across nut	SW	[mm]	13	13	17	17	19	19	19	19	19	19
Amount of adhesive per drill hole ³⁾		[ml]	3,4	4,1	6,1	7,0	7,0	6,8	8,6	9,0	9,2	9,4
Add. amount of adhesive per drill hole for Through fastening per 10mm of fixture thickness		[ml/10mm]	-	-	1,0	1,0	0,7	1,2	1,2	1,2	1,2	1,2
Drill holes per cartridge ³⁾ VMZ 150 / VMZ 280	[Quan.]		31/70	26/58	18/39	15/34	15/34	16/35	12/27	12/26	11/26	11/25
Drill holes per cartridge ³⁾ VMZ 345 / VMZ 420	[Quan.]		88/111	73/92	49/62	43/54	43/54	44/55	34/44	33/42	32/41	32/40

¹⁾For edge distance c ≥ 80 mm, minimal spacing distance s_{min} = 55 mm
²⁾The annular gap of the clearance hole must be completely filled with adhesive after fixing.
³⁾Values shown are for pre-installation. For through fastening additional adhesive is required to completely fill the clearance hole in the fixture.
⁴⁾Not for use in through fastening applications.
⁵⁾Max. long term temperature +50 °C / max. short term temperature +80 °C

Installation (Pre-installation)

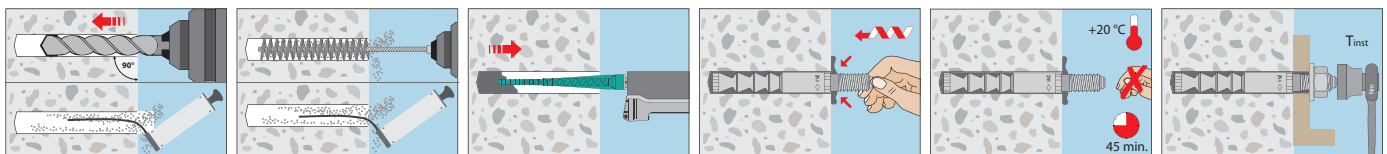

Installation (Through fastening)

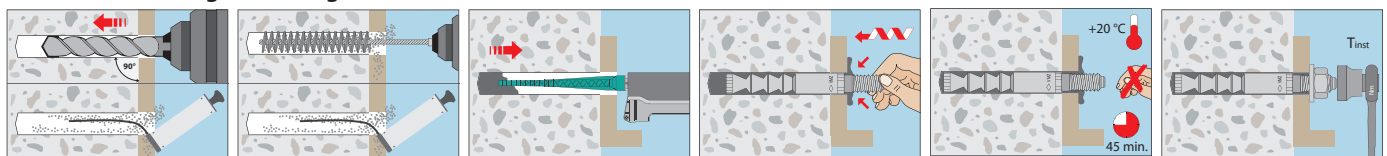



Extract from Permissible Service Conditions of European Technical Assessment ETA-04/0092

Approved loads (static or quasi-static) for single anchor without influence of spacing and edge distance for temperature range -40°C to +80°C⁴⁾ (Approved loads for temperature range -40°C to +120°C see ETA-04/0092). Total safety factor as per ETAG 001 included (γ_M and γ_F). Load capacities under fire exposure see page 168.

Loads and performance data Injection System VMZ, steel zinc plated M16-M24



			90	105	125	145	160	115	170	190	170	200	225
			M16	M16	M16	M16	M16	M20	M20 LG	M20 LG	M24 LG	M24 LG	M24 LG
cracked concrete													
Mean ultimate loads, tension	C25/30 Num	[kN]	49,0	74,8	108,7	108,7	114,7	103,3	149,6	149,6	146,2	200,9	200,9
Mean ultimate loads, shear	C25/30 Vum	[kN]	62,8	62,8	62,8	62,8	62,8	68,6	150,7(98,0 ³⁾)	150,7(98,0 ³⁾)	179,5(140,8 ³⁾)	179,5(140,8 ³⁾)	179,5(140,8 ³⁾)
Approved loads, tension	C20/25 appr. N	[kN]	14,6	18,4	24,0	29,9	34,7	21,1	38,0	44,9	38,0	48,5	57,9
	C25/30 appr. N	[kN]	16,0	20,2	26,2	32,8	38,0	23,2	41,6	49,2	41,6	53,1	63,4
	C30/37 appr. N	[kN]	17,8	22,4	29,1	36,4	42,2	25,7	46,2	54,6	46,2	59,0	70,4
	C40/50 appr. N	[kN]	20,7	26,1	33,9	42,3	46,2	29,9	53,7	63,5	53,7	68,6	81,8
	C50/60 appr. N	[kN]	22,7	28,6	37,1	46,4	46,2	32,8	58,9	69,6	58,9	75,1	89,6
non-cracked concrete													
Approved loads, tension	C20/25 appr. N	[kN]	20,5	25,8	33,5	35,7	42,9	29,6	53,2	62,9	53,2	67,9	81,0
	C25/30 appr. N	[kN]	22,4	28,3	36,7	39,1	46,2	32,4	58,3	68,9	58,3	74,4	88,7
	C30/37 appr. N	[kN]	24,9	31,4	40,8	43,4	46,2	36,0	64,7	76,5	64,7	82,6	98,5
	C40/50 appr. N	[kN]	29,0	36,5	47,4	50,5	46,2	40,8	75,2	88,9	75,2	96,0	105,7
	C50/60 appr. N	[kN]	31,7	40,0	52,0	52,9	46,2	40,8	82,4	89,5	82,4	105,2	105,7
cracked and non-cracked concrete													
Approved loads, shear	≥ C20/25 appr. V	[kN]	29,3	36,0	36,0	36,0	36,0	35,7	76,0	85,1	76,0	97,0	101,7
Approved loads, shear Type LG	≥ C20/25 appr. V	[kN]	29,3	36,0	36,0	36,0	36,0	35,7	56,0	56,0	76,0	80,6	80,6
Approved bending moments	appr. M	[Nm]	152,0	152,0	152,0	152,0	152,0	200,0	296,6	296,6	512,0	512,0	512,0
Spacing and edge distance													
Effective anchorage depth	h _{ef}	[mm]	90	105	125	145	160	115	170	190	170	200	225
Characteristic spacing	s _{cr,N}	[mm]	270	315	375	435	480	345	510	570	510	600	675
Characteristic edge distance	c _{cr,N}	[mm]	135	157,5	187,5	217,5	240	172,5	255	285	255	300	337,5
cracked concrete													
Minimum thickness of concrete slab	≥ h _{min}	[mm]	130	150	170	190	205	160	230	250	230	270	300
Minimum spacing	s _{min}	[mm]	50	50	60	60	60	80	80	80	80	80	80
Minimum edge distance	c _{min}	[mm]	50	50	60	60	60	80	80	80	80	80	80
non-cracked concrete													
Minimum thickness of concrete slab	≥ h _{min}	[mm]	130	150	170	190	205	160	230	250	230	270	300
Minimum spacing	s _{min}	[mm]	50	60	60	60	60	80	80	80	80	105	105
Minimum edge distance	c _{min}	[mm]	50	60	60	60	60	80	80	80	80	105	105
Installation parameters													
Drill hole diameter	d _o	[mm]	18	18	18	18	18	22	24	24	26	26	26
Diameter of clearance hole in the fixture Pre-installation	d _f	[mm]	18	18	18	18	18	22	24 (22 ³⁾)	24 (22 ³⁾)	26	26	26
Diameter of clearance hole in the fixture Through fastening ¹⁾	d _f	[mm]	20	20	20	20	20	24	26	26	28	28	28
Depth of drill hole	h _o	[mm]	98	113	133	153	168	120	180	200	185	215	240
Installation torque	≤ T _{inst}	[Nm]	50	50	50	50	50	80	80	80	100	120	120
Width across nut	SW	[mm]	24	24	24	24	24	30	30	30	36	36	36
Amount of adhesive per drill hole ²⁾		[ml]	11,1	12,6	14,5	15,8	17,4	20,8	30,1	32,2	33,3	36,6	41,3
Add. amount of adhesive per drill hole for Through fastening per 10mm of fixture thickness		[ml/10mm]	1,6	1,6	1,6	1,6	1,6	2,1	2,9	2,9	2,6	2,6	2,6
Drill holes per cartridge ²⁾ VMZ 150 / VMZ 280		[Quan.]	9/21	8/19	7/16	6/15	6/13	5/11	3/7	3/7	3/7	3/6	2/5
Drill holes per cartridge ²⁾ VMZ 345 / VMZ 420		[Quan.]	27/34	23/30	20/26	19/24	17/21	14/18	10/12	9/11	9/11	8/10	7/9

¹⁾The annular gap of the clearance hole must be completely filled with adhesive after fixing. ³⁾Values in brackets are for Type LG
²⁾Values shown are for pre-installation. For through fastening additional adhesive is required to completely fill the clearance hole in the fixture. ⁴⁾Max. long term temperature +50 °C / max. short term temperature +80 °C

For anchor designing an easy to operate CD-ROM is available on request or can be downloaded at www.mkt.de.

Pre-installation

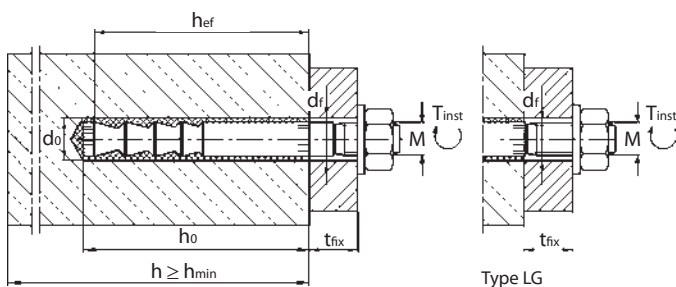

Through fastening

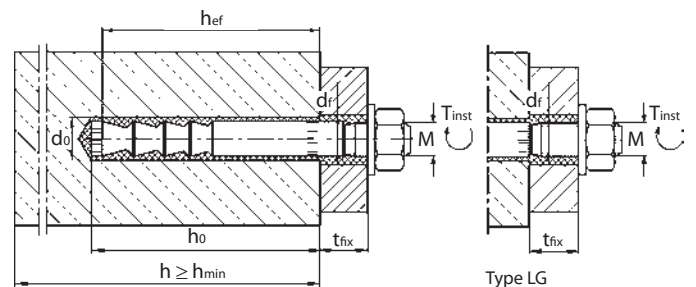



Extract from Permissible Service Conditions of European Technical Assessment ETA-04/0092

Approved loads (static or quasi-static) for single anchor without influence of spacing and edge distance for temperature range -40°C to +80°C³⁾ (Approved loads for temperature range -40°C to +120°C see ETA-04/0092). Total safety factor as per ETAG 001 included (γ_M and γ_P). Load capacities under fire exposure see page 168.

Loads and performance data Injection System VMZ Stainless steel A4 / HCR M8-M12



			40 M8	50 M8	60 M10	75 M10	75 M12	70 M12	80 M12	95 M12	100 M12	110 M12	125 M12
cracked concrete													
Mean ultimate loads, tension	C25/30	Num [kN]	12,3	19,5	28,0	29,5	34,9	41,0	48,2	51,6	67,2	67,2	67,2
Mean ultimate loads, shear	C25/30	V _{um} [kN]	17,6	17,6	27,8	27,8	40,5	40,5	40,5	40,5	40,5	40,5	40,5
Approved loads, tension	C20/25 appr. N	[kN]	4,3	6,1	8,0	11,1	11,1	10,0	12,3	15,9	17,1	19,8	24,0
	C25/30 appr. N	[kN]	4,8	6,6	8,8	11,9	12,2	11,0	13,4	17,4	18,8	21,7	26,2
	C30/37 appr. N	[kN]	5,3	7,4	9,7	11,9	13,5	12,2	14,9	19,3	20,9	24,1	27,1
	C40/50 appr. N	[kN]	6,1	8,6	11,3	11,9	15,7	14,2	17,3	22,4	24,2	27,1	27,1
	C50/60 appr. N	[kN]	6,7	8,6	11,9	11,9	16,7	15,6	19,0	24,6	26,6	27,1	27,1
non-cracked concrete													
Approved loads, tension	C20/25 appr. N	[kN]	4,3	8,5	11,2	11,9	15,6	14,1	17,2	19,0	24,0	23,8	23,8
	C25/30 appr. N	[kN]	4,7	8,6	11,9	11,9	16,7	15,4	18,8	20,9	26,3	26,1	26,1
	C30/37 appr. N	[kN]	5,2	8,6	11,9	11,9	16,7	17,1	20,9	23,2	27,1	27,1	27,1
	C40/50 appr. N	[kN]	6,1	8,6	11,9	11,9	16,7	19,9	24,3	25,7	27,1	27,1	27,1
	C50/60 appr. N	[kN]	6,6	8,6	11,9	11,9	16,7	21,8	25,7	27,1	27,1	27,1	27,1
cracked and non-cracked concrete													
Approved loads, shear	≥ C20/25 appr. V	[kN]	8,6	8,6	13,1	13,1	19,4	19,4	19,4	19,4	19,4	19,4	19,4
Approved loads, shear Type LG	≥ C20/25 appr. V	[kN]	8,6	8,6	13,1	13,1	19,4	19,4	19,4	19,4	19,4	19,4	19,4
Approved bending moments	appr. M	[Nm]	17,1	17,1	34,3	34,	60,0	60,0	60,0	60,0	60,0	60,0	60,0

Spacing and edge distance

Effective anchorage depth	h _{ef}	[mm]	40	50	60	75	75	70	80	95	100	110	125
Characteristic spacing	s _{cr,N}	[mm]	120	150	180	225	225	210	240	285	300	330	375
Characteristic edge distance	c _{cr,N}	[mm]	60	75	90	112,5	112,5	105	120	142,5	150	165	187,5
cracked concrete													
Minimum thickness of concrete slab	≥ h _{min}	[mm]	80	80	100	110	110	110	110	130	130	140	160
Minimum spacing	s _{min}	[mm]	40	40	40	40	50	55	40	40	50	50	50
Minimum edge distance	c _{min}	[mm]	40	40	40	40	50	55	50	50	50	50	50
non-cracked concrete													
Minimum thickness of concrete slab	≥ h _{min}	[mm]	80	80	100	110	110	110	110	130	130	140	160
Minimum spacing	s _{min}	[mm]	40	40	50	50	50	55	55	55	801)	801)	801)
Minimum edge distance	c _{min}	[mm]	40	40	50	50	50	55	55	55	551)	551)	551)

Installation parameters

Drill hole diameter	d _o	[mm]	10	10	12	12	12	14	14	14	14	14	14
Diameter of clearance hole in the fixture Pre-installation	d _f	[mm]	9	9	12	12	14	14	14	14	14	14	14
Diameter of clearance hole in the fixture Through fastening ²⁾	d _f	[mm]	-4)	-4)	14	14	14	16	16	16	16	16	16
Depth of drill hole	h _o	[mm]	42	55	65	80	80	75	85	100	105	115	130
Installation torque	≤ T _{inst}	[Nm]	10	10	15	15	25	25	25	25	30	30	30
Width across nut	SW	[mm]	13	13	17	17	19	19	19	19	19	19	19
Amount of adhesive per drill hole ³⁾		[ml]	3,4	4,1	6,1	7,0	7,0	6,8	8,6	9,0	9,2	9,4	9,6
Add. amount of adhesive per drill hole for Through fastening per 10mm of fixture thickness		[ml/10mm]	-	-	1,0	1,0	0,7	1,2	1,2	1,2	1,2	1,2	1,2
Drill holes per cartridge ³⁾ VMZ 150/VMZ 280	[Quan.]		31/70	26/58	18/39	15/34	15/34	16/35	12/27	12/26	11/26	11/25	11/24
Drill holes per cartridge ³⁾ VMZ 345/VMZ 420	[Quan.]		88/111	73/92	49/62	43/54	43/54	44/55	34/44	33/42	32/41	32/40	31/39

¹⁾For edge distance c ≥ 80 mm, minimal spacing distance s_{min} = 55 mm

²⁾The annular gap of the clearance hole must be completely filled with adhesive after fixing.

³⁾Values shown are for pre-installation. For through fastening additional adhesive is required to completely fill the clearance hole in the fixture.

⁴⁾Not for use in through fastening applications.

⁵⁾Max. long term temperature +50 °C / max. short term temperature +80 °C

Installation (Pre-installation)

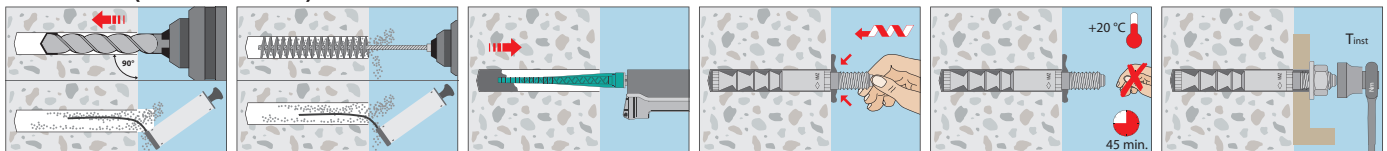

Installation (Through fastening)

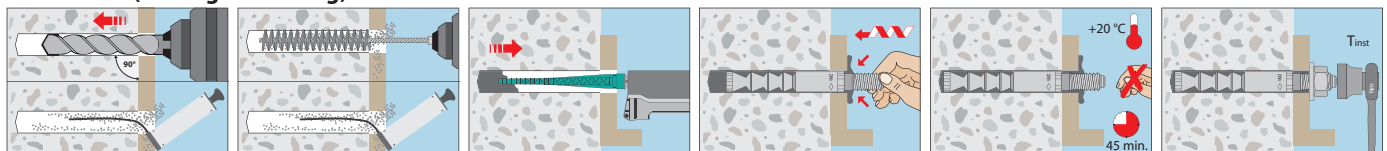



Extract from Permissible Service Conditions of European Technical Assessment ETA-04/0092

Approved loads (static or quasi-static) for single anchor without influence of spacing and edge distance for temperature range -40°C to +80°C⁴⁾ (Approved loads for temperature range -40°C to +120°C see ETA-04/0092). Total safety factor as per ETAG 001 included (γ_M and γ_F). Load capacities under fire exposure see page 168.

Loads and performance data Injection System VMZ Stainless steel A4 / HCR M16-M24

			90 M16	105 M16	125 M16	145 M16	160 M16	115 M20	170 M20 LG	190 M20 LG	170 M24 LG	200 M 24 LG	225 M24 LG
cracked concrete													
Mean ultimate loads, tension	C25/30	Num [kN]	49,0	74,8	108,7	108,7	114,7	103,3	149,6	149,6	146,2	200,9	200,9
Mean ultimate loads, shear	C25/30	V _{um} [kN]	75,4	75,4	75,4	75,4	75,4	102,9	158,2(102,9 ³⁾)	158,2(102,9 ³⁾)	188,4(147,8 ³⁾)	188,4(147,8 ³⁾)	188,4(147,8 ³⁾)
Approved loads, tension	C20/25 appr. N	[kN]	14,6	18,4	24,0	29,9	34,7	21,1	38,0	44,9	38,0	48,5	57,9
	C25/30 appr. N	[kN]	16,0	20,2	26,2	32,8	38,0	23,2	41,6	49,2	41,6	53,1	63,4
	C30/37 appr. N	[kN]	17,8	22,4	29,1	36,4	42,2	25,7	46,2	54,6	46,2	59,0	70,4
	C40/50 appr. N	[kN]	20,7	26,1	33,9	42,3	46,2	29,9	53,7	63,5	53,7	68,6	81,8
	C50/60 appr. N	[kN]	22,7	28,6	37,1	46,4	46,2	32,8	58,9	69,6	58,9	75,1	89,6
non-cracked concrete													
Approved loads, tension	C20/25 appr. N	[kN]	20,5	25,8	33,5	35,7	42,9	29,6	53,2	62,9	53,2	67,9	81,0
	C25/30 appr. N	[kN]	22,4	28,3	36,7	39,1	46,2	32,4	58,3	68,9	58,3	74,7	88,7
	C30/37 appr. N	[kN]	24,9	31,4	40,8	43,4	46,2	36,0	64,7	76,5	64,7	82,6	92,4
	C40/50 appr. N	[kN]	29,0	36,5	47,4	50,5	46,2	41,9	75,2	78,6	75,2	92,4	92,4
	C50/60 appr. N	[kN]	31,7	40,0	52,0	52,9	46,2	45,9	78,6	78,6	82,4	92,4	92,4
cracked and non-cracked concrete													
Approved loads, shear	≥ C20/25 appr. V	[kN]	29,3	36,0	36,0	36,0	36,0	42,3	74,9	74,9	76,0	89,1	89,1
Approved loads, shear Type LG	≥ C20/25 appr. V	[kN]	29,3	36,0	36,0	36,0	36,0	42,3	49,1	49,1	70,3	70,3	70,3
Approved bending moments	appr. M	[Nm]	152,0	152,0	152,0	152,0	152,0	231,6	259,4	259,4	448,0	448,0	448,0
Spacing and edge distance													
Effective anchorage depth	h _{ef}	[mm]	90	105	125	145	160	115	170	190	170	200	225
Characteristic spacing	s _{cr,N}	[mm]	270	315	375	435	480	345	510	570	510	600	675
Characteristic edge distance	c _{cr,N}	[mm]	135	157,5	187,5	217,5	240	172,5	255	285	255	300	337,5
cracked concrete													
Minimum thickness of concrete slab	≥ h _{min}	[mm]	130	150	170	190	205	160	230	250	230	270	300
Minimum spacing	s _{min}	[mm]	50	50	60	60	60	80	80	80	80	80	80
Minimum edge distance	c _{min}	[mm]	50	50	60	60	60	80	80	80	80	80	80
non-cracked concrete													
Minimum thickness of concrete slab	≥ h _{min}	[mm]	130	150	170	190	205	160	230	250	230	270	300
Minimum spacing	s _{min}	[mm]	50	60	60	60	60	80	80	80	80	105	105
Minimum edge distance	c _{min}	[mm]	50	60	60	60	60	80	80	80	80	105	105
Installation parameters													
Drill hole diameter	d _o	[mm]	18	18	18	18	18	22	24	24	26	26	26
Diameter of clearance hole in the fixture Pre-installation	d _f	[mm]	18	18	18	18	18	22	24 (22 ³⁾)	24 (22 ³⁾)	26	26	26
Diameter of clearance hole in the fixture Through fastening ¹⁾	d _f	[mm]	20	20	20	20	20	24	26	26	28	28	28
Depth of drill hole	h _o	[mm]	98	113	133	153	168	120	180	200	185	215	240
Installation torque	≤ T _{inst}	[Nm]	50	50	50	50	50	80	80	80	100	120	120
Width across nut	SW	[mm]	24	24	24	24	24	30	30	30	36	36	36
Amount of adhesive per drill hole ²⁾		[ml]	11,1	12,6	14,5	15,8	17,4	20,8	30,1	32,2	33,3	36,6	41,3
Add. amount of adhesive per drill hole for Through fastening per 10mm of fixture thickness		[ml/10mm]	1,6	1,6	1,6	1,6	1,6	2,1	2,9	2,9	2,6	2,6	2,6
Drill holes per cartridge ²⁾ VMZ 150/VMZ 280		[Quan.]	9/21	8/19	7/16	6/15	6/13	5/11	3/7	3/7	3/7	3/6	2/5
Drill holes per cartridge ²⁾ VMZ 345/VMZ 420		[Quan.]	27/34	23/30	20/26	19/24	17/21	14/18	10/12	9/11	9/11	8/10	7/9

¹⁾The annular gap of the clearance hole must be completely filled with adhesive after fixing. ³⁾Values in brackets are for Type LG
²⁾Values shown are for pre-installation. For through fastening additional adhesive is required to completely fill the clearance hole in the fixture. ⁴⁾Max. long term temperature +50 °C / max. short term temperature +80 °C

For anchor designing an easy to operate CD-ROM is available on request or can be downloaded at www.mkt.de.

Pre-installation

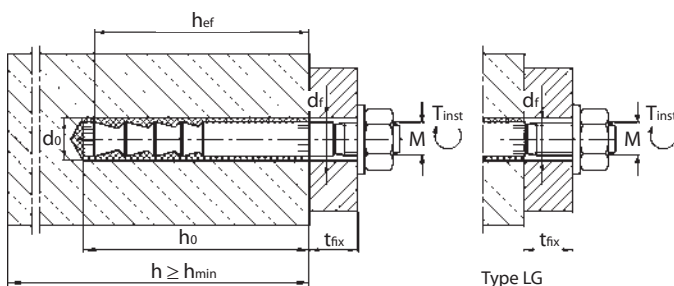

Through fastening

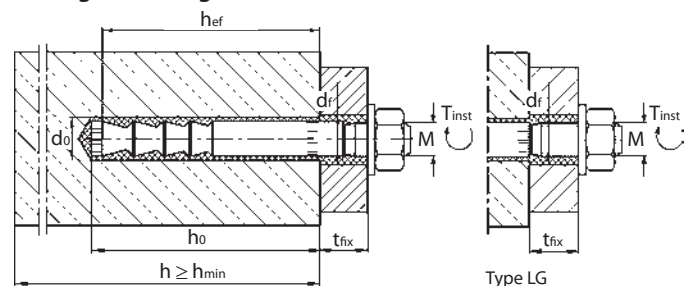

Injection System VMZ-IG



Conical Stud VMZ-IG
with internal thread



Cartridge VMZ 150
Coaxial Cartridge
for silicone guns
Content: 150ml



Cartridge VMZ 280
Coaxial Cartridge
for silicone guns
Content: 280ml, incl. 2 Static
mixer on Cartridge

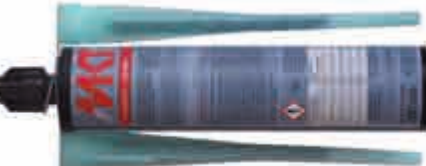

Cartridge VMZ 345
Side-by-side Cartridge
Content: 345ml



Cartridge VMZ 420
Coaxial Cartridge
Content: 420ml



**Cartridge VMZ 345
express**
Side-by-side Cartridge
Content: 345ml

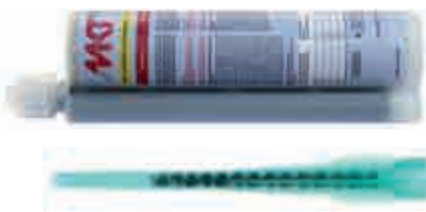

Range of loading: 4,3 kN - 53,2 kN
Range of concrete quality: C20/25 - C50/60
Material: Steel, zinc plated, Stainless steel A4,
Stainless steel HCR

Description

The Injection System VMZ-IG consists of an internally threaded sleeve with conical expansion elements and a 2 component injection adhesive. This combination provides extremely high load bearing capacity even at minimum edge distance and spacing. The VMZ system combines the benefits of bonded anchors and expansion anchors in a European technical approved fastening system for both cracked and non-cracked concrete.



Advantages:

- Small thickness of concrete slab
- No load reduction for wet or water-filled (M10 and larger) drill holes
- Approved from -5 °C to +40°C temperature of base material while installation
- No projection parts after de-installation of fixture
- Opened cartridges can be re-used with a new mixer nozzle

Applications:

Heavy duty fastenings in cracked and non-cracked concrete with standards screws or threaded studs: Steel structures, brackets, railings, posts, columns, ladders, gates

Injection Cartridge VMZ



- Two component cartridge, styrene-free
- Various cartridge systems
- Approved for cracked and non-cracked concrete

Description	Ref. No.	Content	Content of master box	Weight per master box	Weight per piece
		ml	pcs.	kg	kg
Cartridge VMZ 150	28999301	150	12	4,32	0,36
Cartridge VMZ 280 ¹⁾	28252601	280	12	6,70	0,56
Cartridge VMZ 345	28255310	345	12	8,28	0,69
Cartridge VMZ 420	28254701	420	12	9,84	0,83
Cartridge VMZ 345 express	28254201	345	12	8,00	0,65
Static mixer VM-X (for all cartridge)	28305111	-	12	0,12	0,01
Mixer extension VM-XE 10/200 (200mm)	28306011	-	12	-	0,01
Installation wedge VMZ-MK	33300103	-	10	-	0,01

One static mixer VM-X as well as one screw-on cap comes with each cartridge.

Usable length of static mixer see page 84.

¹⁾Cartridge VMZ 280 comes with 2 mixers.

Dispenser and Accessories for drill hole cleaning see page 84/85.

Conical Stud VMZ-IG

Steel, zinc plated



→ For use in structures subject to dry internal conditions

→ With internal thread, to be used with standard screws or threaded studs (steel strength 8.8)

Description	Ref. No.	Drill hole Ø x depth mm	Effective anchorage depth	Anchor length mm	Thread	Pkg. cont. pcs.	Weight per pkg. kg
VMZ-IG 40 M6	32802101	10x42	40	41	M6x12	10	0,15
VMZ-IG 50 M6	32804101	10x55	50	52	M6x15	10	0,18
VMZ-IG 60 M8	32812101	12x65	60	63	M8x16	10	0,28
VMZ-IG 75 M8	32814101	12x80	75	78	M8x19	10	0,47
VMZ-IG 70 M10	32822101	14x80	70	74	M10x20	10	0,57
VMZ-IG 80 M10	32824101	14x85	80	84	M10x23	10	0,63
VMZ-IG 90 M12	32832101	18x98	90	94	M12x24	10	1,26
VMZ-IG 105 M12	32834101	18x113	105	109	M12x27	10	1,45
VMZ-IG 125 M12	32836101	18x133	125	130	M12x30	10	1,69
VMZ-IG 115 M16	32852101	22x120	115	120	M16x32	5	1,12
VMZ-IG 170 M16	32854101	24x180	170	180	M16x32	5	2,22
VMZ-IG 170 M20	32862101	26x185	170	182	M20x40	5	2,44

Conical Stud VMZ-IG A4

Stainless steel A4 / 316



→ For use in structures subject to dry internal conditions or external atmospheric exposure

→ With internal thread, to be used with standard screws or threaded studs (steel strength 70)

Description	Ref. No.	Drill hole Ø x depth mm	Effective anchorage depth	Anchor length mm	Thread	Pkg. cont. pcs.	Weight per pkg. kg
VMZ-IG 40 M6 A4	32802501	10x42	40	41	M6x12	10	0,15
VMZ-IG 50 M6 A4	32804501	10x55	50	52	M6x15	10	0,18
VMZ-IG 60 M8 A4	32812501	12x65	60	63	M8x16	10	0,28
VMZ-IG 75 M8 A4	32814501	12x80	75	78	M8x19	10	0,47
VMZ-IG 70 M10 A4	32822501	14x80	70	74	M10x20	10	0,57
VMZ-IG 80 M10 A4	32824501	14x85	80	84	M10x23	10	0,63
VMZ-IG 90 M12 A4	32832501	18x98	90	94	M12x24	10	1,26
VMZ-IG 105 M12 A4	32834501	18x113	105	109	M12x27	10	1,45
VMZ-IG 125 M12 A4	32836501	18x133	125	130	M12x30	10	1,69
VMZ-IG 115 M16 A4	32852501	22x120	115	120	M16x32	5	1,12
VMZ-IG 170 M16 A4	32854501	24x180	170	180	M16x32	5	2,22
VMZ-IG 170 M20 A4	32862501	26x185	170	182	M20x40	5	2,44

HCR on demand.

Curing Time Injection Adhesive VMZ

→ Cartridge temperature when installing
min. +5°C

Temperature (°C) of the base material	Gel time	Curing time	
		dry base material	wet base material
-5°C	1:30 h	6:00 h	12:00 h ¹⁾
-4°C to -1°C	45 min	6:00 h	12:00 h ¹⁾
0°C to +4°C	20 min	3:00 h	6:00 h
+5°C to +9°C	12 min	2:00 h	4:00 h
+10°C to +19°C	6 min	1:20 h	2:40 h
+20°C to +29°C	4 min	45 min	1:30 h
+30°C to +34°C	2 min	25 min	50 min
+35°C to +39°C	1,4 min	20 min	40 min
+40°C	1,4 min	15 min	30 min

¹⁾It must be ensured that icing does not occur in the drill hole.
The hole must be drilled and cleaned directly prior to the installation of the anchor.

Curing Time Injection Adhesive VMZ express

→ Cartridge temperature when installing
min. +5°C

Temperature (°C) of the base material	Gel time	Curing time	
		dry base material	wet base material
-5°C	40 min	4:00 h	8:00 h ¹⁾
-4°C to -1°C	20 min	4:00 h	8:00 h ¹⁾
0°C to +4°C	10 min	2:00 h	4:00 h
+5°C to +9°C	6 min	1:00 h	2:00 h
+10°C to +19°C	3 min	40 min	80 min
+20°C to +29°C	1 min	20 min	40 min
+30°C	1 min	10 min	20 min

¹⁾It must be ensured that icing does not occur in the drill hole.
The hole must be drilled and cleaned directly prior to the installation of the anchor.



Extract from Permissible Service Conditions of ETA-04/0092

Approved loads for single anchor without influence of spacing and edge distance for temperature range -40°C to +80°C¹⁾ (Approved loads for temperature range -40°C to +120°C see ETA-04/0092). Total safety factor as per ETAG 001 included (γ_M and γ_P).

Loads and performance data

Injection System VMZ-IG, steel zinc plated and stainless steel A4 / HCR



				40 M6	50 M6	60 M8	75 M8	70 M10	80 M10	90 M12	105 M12	125 M12	115 M16	170 M16	170 M20
VMZ-IG, steel zinc plated				cracked concrete											
Approved loads, tension	C20/25	appr. N	[kN]	4,3	6,1	8,0	11,1	10,0	12,3	14,6	18,4	24,0	21,1	38,0	38,0
non-cracked concrete															
Approved loads, tension	C20/25	appr. N	[kN]	4,3	7,6	9,0	13,8	14,1	16,7	20,5	25,8	31,9	24,8	53,2	51,4
cracked and non-cracked concrete															
Approved loads, shear	≥ C20/25	appr. V	[kN]	4,6	4,6	5,4	8,6	10,3	10,3	19,4	19,4	19,4	14,9	36,0	30,9
Approved bending moments		appr. M	[Nm]	6,9	6,9	17,1	17,1	34,3	34,3	60,0	60,0	60,0	121,1	152,0	296,6

				cracked concrete											
Approved loads, tension	C20/25	appr. N	[kN]	4,3	5,2	8,0	10,0	10,0	12,3	14,6	18,4	22,4	21,1	38,0	38,0
non-cracked concrete															
Approved loads, tension	C20/25	appr. N	[kN]	4,3	5,2	9,0	10,0	14,1	15,7	20,5	22,4	22,4	29,6	41,9	44,8
cracked and non-cracked concrete															
Approved loads, shear	≥ C20/25	appr. V	[kN]	3,1	3,1	5,4	5,7	9,1	9,1	13,7	13,7	13,7	18,3	25,1	26,9
Approved bending moments		appr. M	[Nm]	4,9	4,9	12,0	12,0	24,0	24,0	42,3	42,3	42,3	106,9	106,9	208,6

Spacing and edge distance

Effective anchorage depth	h_{ef}	[mm]	40	50	60	75	70	80	90	105	125	115	170	170
Characteristic spacing	$s_{cr,N}$	[mm]	120	150	180	225	210	240	270	315	375	345	510	510
Characteristic edge distance	$c_{cr,N}$	[mm]	60	75	90	112,5	105	120	135	157,5	187,5	172,5	255	255
			cracked concrete											
Minimum thickness of concrete slab	≥ h_{min}	[mm]	80	80	100	110	110	110	130	150	170	160	230	230
Minimum spacing	s_{min}	[mm]	40	40	40	40	55	40	50	50	60	80	80	80
Minimum edge distance	c_{min}	[mm]	40	40	40	40	55	50	50	50	60	80	80	80
			non-cracked concrete											
Minimum thickness of concrete slab	≥ h_{min}	[mm]	80	80	100	110	110	110	130	150	170	160	230	230
Minimum spacing	s_{min}	[mm]	40	40	50	50	55	55	50	60	60	80	80	80
Minimum edge distance	c_{min}	[mm]	40	40	50	50	55	55	50	60	60	80	80	80

Installation parameters

Drill hole diameter	d_o	[mm]	10	10	12	12	14	14	18	18	18	22	24	26
Diameter of clearance hole in the fixture	d_f	[mm]	7	7	9	9	12	12	14	14	14	18	18	22
Depth of drill hole	h_o	[mm]	42	55	65	80	80	85	98	113	133	120	180	185
Installation torque	≤ T_{inst}	[Nm]	8	8	10	10	15	15	25	25	25	50	50	80
Minimum screwing depth	L_{sdmin}	[mm]	7	7	9	9	12	12	14	14	14	18	18	22
Maximum screwing depth	L_{th}	[mm]	12	15	16	19	20	23	24	27	30	32	32	40
Amount of adhesive per drill hole		[ml]	3,4	4,1	6,1	7,0	6,8	8,6	11,1	12,6	14,5	20,8	30,1	33,3
Drill holes per cartridge VMZ 150/VMZ 280		[Quan.]	31/70	26/58	18/39	15/34	16/35	12/27	9/21	8/19	7/16	5/11	3/7	3/7
Drill holes per cartridge VMZ 345		[Quan.]	88	73	49	43	44	34	27	23	20	14	10	9
Drill holes per cartridge VMZ 420		[Quan.]	111	92	62	54	55	44	34	30	26	18	12	11

¹⁾Max. long term temperature +50 °C / max. short term temperature +80 °C

For anchor designing an easy to operate CD-ROM is available on request or can be downloaded at www.mkt.de.

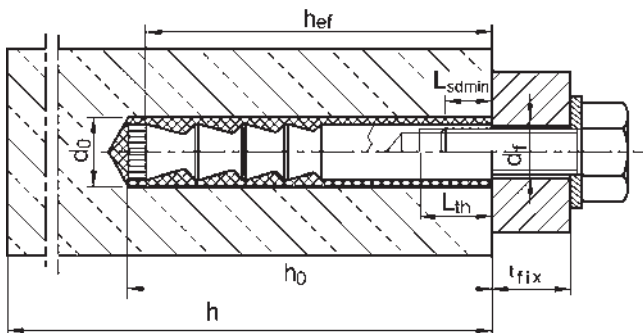

Installation

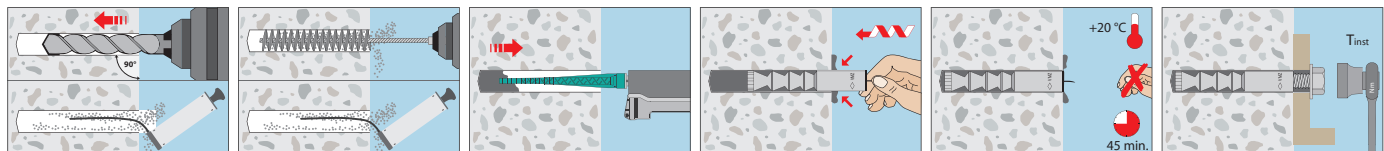

Injection System VMZ **dynamic**



Conical Stud VMZ-A dynamic
Through Fastening



Conical Stud VMZ-AV dynamic
Pre-Installation



Cartridge VMZ 150
Coaxial Cartridge for silicone guns
Content: 150ml

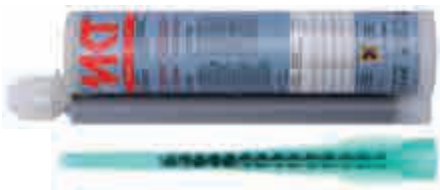

Cartridge VMZ 345
Side-by-side Cartridge
Content: 345ml



Cartridge VMZ 420
Coaxial Cartridge
Content: 420ml

Range of loading: 4,7 kN - 31,9 kN
Range of concrete quality: C20/25 - C50/60
Material: Steel, zinc plated, Stainless steel HCR

Description

The Injection System VMZ dynamic consists of an anchor rod with conical expansion elements and a 2 component injection adhesive. This combination provides extremely high load bearing capacity even at minimum edge distance and spacing. The VMZ system combines the benefits of bonded anchors and expansion anchors in an approved fastening system for both cracked and non-cracked concrete.

Advantages:

- Small thickness of concrete slab
- No load reduction for wet or water-filled drill holes
- Approved from -5 °C to +40°C temperature of base material while installing
- Through-setting installation or pre-installation
- Special nut and washer to account for angular misalignment
- Opened cartridges can be re-used with a new mixer nozzle
- Pre-assembled anchor, additional locknut included
- Very high loads in axial and oblique tension
- Higher loads, if the number of load cycles is limited
- Static and alternating loads may be taken into account in the design of the anchorage

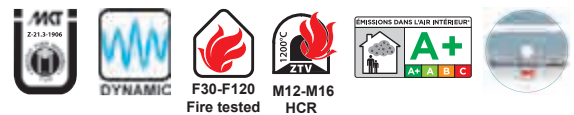

Applications

Heavy duty fastenings with alternating loads and unlimited load cycles in cracked and non-cracked concrete:
 Cranes, industrial robots, antenna towers, noise barriers, elevators

Injection Cartridge VMZ



- Two component cartridge, styrene-free
- Various cartridge systems
- Approved for cracked and non-cracked concrete

Description	Ref. No.	Content	Content of master box pcs.	Weight per master box kg	Weight per piece kg
Cartridge VMZ 150	28999301	150	12	4,32	0,36
Cartridge VMZ 280 ¹⁾	28252601	280	12	6,70	0,56
Cartridge VMZ 345	28255310	345	12	8,28	0,69
Cartridge VMZ 420	28254701	420	12	9,84	0,83
Cartridge VMZ 345 express	28254201	345	12	8,00	0,65
Static mixer VM-X (for all cartridge)	28305111	-	12	0,12	0,01
Mixer extension VM-XE 10/200 (200mm)	28306011	-	12	-	0,01
Installation wedge VMZ-MK	33300103	-	10	-	0,01

One static mixer as well as one screw-on cap comes with each cartridge.

Usable length of static mixer see page 84.

¹⁾Cartridge VMZ 280 comes with 2 mixers.

Dispenser and Accessories for drill hole cleaning see page 97.

Through-fastening installation

Conical Stud VMZ-A dynamic

Steel zinc plated, Through Fastening



→ Through-setting installation: Pre-assembled set of conical Stud, concave washer, ball nut, lock nut and a plastic sleeve as a thread protector.

→ For use in structures subject to dry internal conditions

Description	Ref. No.	Drill hole Ø do mm	Drill hole depth ho mm		Fixture thickness tfx mm		Drill hole depth through fixture hd mm	Concave washer ¹⁾ d1 x h1 mm	Anchor length mm	Pkg. cont. pcs.	Weight per pkg. kg	Amount of adhesive per anchor ml	Anchors per cartridge			
			min	max	min	max							150 ml	280 ml	345 ml	420ml
VMZ-A 100 M12-25/160 dyn	36375101	14	105	118	12	25	130	36 x 6	160	10	2,22	12,2	9	19	25	31
VMZ-A 100 M12-50/185 dyn	36385101	14	105	143	12	50	155	36 x 6	185	10	2,46	15,2	7	15	20	25
VMZ-A 125 M16-30/200 dyn	36520101	18	133	147	16	30	163	44 x 7	200	10	4,20	19,3	5	12	15	19
VMZ-A 125 M16-50/220 dyn	36525101	18	133	167	16	50	183	44 x 7	220	10	4,54	22,5	4	10	13	16
VMZ-A 170 M20-50/280 dyn	36610101	24	180	210	20	50	230	50 x 8	280	5	4,64	44,6	2	5	6	8

Conical Stud VMZ-A dynamic A4

Stainless steel A4, Through Fastening



→ Through-setting installation: Pre-assembled set of conical Stud, concave washer, ball nut, lock nut and a plastic sleeve as a thread protector.

→ For use in structures subject to external atmospheric exposure.
Conical stud: Stainless steel HCR; concave washer, ball nut, lock nut: Stainless steel A4/316

Description	Ref. No.	Drill hole Ø do mm	Drill hole depth ho mm		Fixture thickness tfx mm		Drill hole depth through fixture hd mm	Concave washer ¹⁾ d1 x h1 mm	Anchor length mm	Pkg. cont. pcs.	Weight per pkg. kg	Amount of adhesive per anchor ml	Anchors per cartridge			
			min	max	min	max							150 ml	280 ml	345 ml	420ml
VMZ-A 100 M12-25/153 dyn A4	36375501	14	105	118	12	25	130	30 x 6	153	10	2,22	12,2	9	19	25	31
VMZ-A 100 M12-50/178 dyn A4	36385501	14	105	143	12	50	155	30 x 6	178	10	2,46	15,2	7	15	20	25
VMZ-A 125 M16-25/185 dyn A4	36520501	18	133	142	16	25	158	40 x 7	185	10	3,02	18,5	6	12	16	20
VMZ-A 125 M16-50/210 dyn A4	36525501	18	133	167	16	50	183	40 x 7	210	10	3,44	22,5	4	10	13	16

Conical Stud VMZ-A dynamic HCR

Stainless steel HCR, Through Fastening



→ Through-setting installation: Pre-assembled set of conical Stud, concave washer, ball nut, lock nut and a plastic sleeve as a thread protector.

→ For use in structures subject to external atmospheric exposure and in particularly corrosive environments

Description	Ref. No.	Drill hole Ø do mm	Drill hole depth ho mm		Fixture thickness tfx mm		Drill hole depth through fixture hd mm	Concave washer ¹⁾ d1 x h1 mm	Anchor length mm	Pkg. cont. pcs.	Weight per pkg. kg	Amount of adhesive per anchor ml	Anchors per cartridge			
			min	max	min	max							150 ml	280 ml	345 ml	420ml
VMZ-A 100 M12-25/153 dyn HCR	36375651	14	105	118	12	25	130	30 x 6	153	10	2,22	12,2	9	19	25	31
VMZ-A 100 M12-50/178 dyn HCR	36385651	14	105	143	12	50	155	30 x 6	178	10	2,46	15,2	7	15	20	25
VMZ-A 125 M16-25/185 dyn HCR	36520651	18	133	142	16	25	158	40 x 7	185	10	3,02	18,5	6	12	16	20
VMZ-A 125 M16-50/210 dyn HCR	36525651	18	133	167	16	50	183	40 x 7	210	10	3,44	22,5	4	10	13	16

¹⁾Outer diameter d1 x thickness h1
Other lengths on demand.

Installation

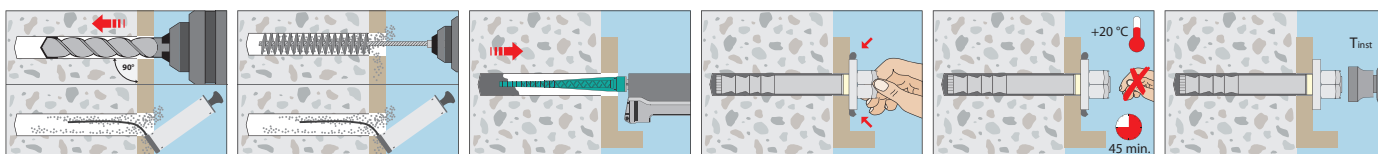

Pre-Installation

Conical Stud VMZ-AV dynamic

Steel zinc plated, Pre-Installation



→ Pre-installation: Set of conical Stud, concave washer with diagonal fill hole, ball nut, lock nut and mixer tips to fill the annular gap in the fixture. Each pack of 10 anchors include 5 mixer tips, each pack of 5 anchors include 3 mixer tips.

→ For use in structures subject to dry internal conditions

Description	Ref. No.	Drill hole Ø do mm	Fixture thickness t _{fix} mm		Drill hole depth ¹⁾ h _o mm	Concave washer ²⁾ d ₁ x h ₁ mm	Anchor length mm	Pkg. cont. pcs.	Weight per pkg. kg	Amount of adhesive per anchor ml	Anchors per cartridge			
			min	max							150 ml	280 ml	345 ml	420ml
VMZ-AV 100 M12-25/160 dyn	36390101	14	12	25	130-tfix	35 x 6	160	10	2,22	12,2	9	19	25	31
VMZ-AV 100 M12-50/185 dyn	36395101	14	12	50	155-tfix	35 x 6	185	10	2,46	15,2	7	15	20	25
VMZ-AV 125 M16-30/200 dyn	36570101	18	16	30	163-tfix	40 x 7	200	10	4,20	19,3	5	12	15	19
VMZ-AV 125 M16-50/220 dyn	36575101	18	16	50	183-tfix	40 x 7	220	10	4,54	22,5	4	10	13	16
VMZ-AV 170 M20-50/280 dyn	36670101	24	20	50	230-tfix	50 x 8	280	5	4,64	44,6	2	5	6	8

Conical Stud VMZ-AV dynamic A4

Stainless steel A4, Pre-Installation



→ Pre-installation: Set of conical Stud, concave washer with diagonal fill hole, ball nut, lock nut and mixer tips to fill the annular gap in the fixture. Each pack of 10 anchors include 5 mixer tips, each pack of 5 anchors include 3 mixer tips.

→ For use in structures subject to external atmospheric exposure and in particularly corrosive environments

Description	Ref. No.	Drill hole Ø do mm	Fixture thickness t _{fix} mm		Drill hole depth ¹⁾ h _o mm	Concave washer ²⁾ d ₁ x h ₁ mm	Anchor length mm	Pkg. cont. pcs.	Weight per pkg. kg	Amount of adhesive per anchor ml	Anchors per cartridge			
			min	max							150 ml	280 ml	345 ml	420ml
VMZ-AV 100 M12-25/153 dyn A4	36390501	14	12	25	130-tfix	35 x 6	153	10	2,22	12,2	9	19	25	31
VMZ-AV 100 M12-50/178 dyn A4	36395501	14	12	50	155-tfix	35 x 6	178	10	2,46	15,2	7	15	20	25
VMZ-AV 125 M16-25/185 dyn A4	36570501	18	16	25	158-tfix	40 x 7	185	10	3,02	18,5	6	12	16	20
VMZ-AV 125 M16-50/210 dyn A4	36575501	18	16	50	183-tfix	40 x 7	210	10	3,44	22,5	4	10	13	16

Conical Stud VMZ-AV dynamic HCR

Stainless steel HCR, Pre-Installation



→ Pre-installation: Set of conical Stud, concave washer with diagonal fill hole, ball nut, lock nut and mixer tips to fill the annular gap in the fixture. Each pack of 10 anchors include 5 mixer tips, each pack of 5 anchors include 3 mixer tips.

→ For use in structures subject to external atmospheric exposure and in particularly corrosive environments

Description	Ref. No.	Drill hole Ø do mm	Fixture thickness t _{fix} mm		Drill hole depth ¹⁾ h _o mm	Concave washer ²⁾ d ₁ x h ₁ mm	Anchor length mm	Pkg. cont. pcs.	Weight per pkg. kg	Amount of adhesive per anchor ml	Anchors per cartridge			
			min	max							150 ml	280 ml	345 ml	420ml
VMZ-AV 100 M12-25/153 dyn HCR	36390651	14	12	25	130-tfix	35 x 6	153	10	2,22	12,2	9	19	25	31
VMZ-AV 100 M12-50/178 dyn HCR	36395651	14	12	50	155-tfix	35 x 6	178	10	2,46	15,2	7	15	20	25
VMZ-AV 125 M16-25/185 dyn HCR	36570651	18	16	25	158-tfix	40 x 7	185	10	3,02	18,5	6	12	16	20
VMZ-AV 125 M16-50/210 dyn HCR	36575651	18	16	50	183-tfix	40 x 7	210	10	3,44	22,5	4	10	13	16

¹⁾The optimum drill hole depth must be calculated with the actual fixture thickness (t_{fix})

²⁾Outer diameter d₁ x thickness h₁

Installation

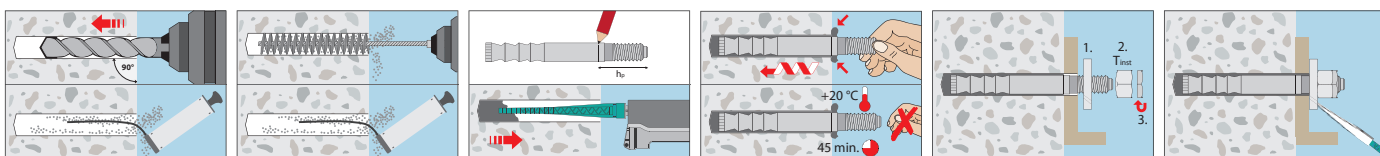



Extract from Permissible Service Conditions of Approval Z-21.3-1906

Approved loads from not static loading for single anchor without influence of spacing and edge distance for temperature range -40°C to +80°C¹⁾ Total safety factor as per ETAG 001 included (γ_M and γ_F).

Loads and performance data

Injection System VMZ dynamic



			100 M 12 steel zinc plated	125 M 16 steel zinc plated	170 M 20 steel zinc plated	100 M 12 A4/HCR	125 M 16 A4/HCR	
Effective anchorage depth	h_{ef}	[mm]	100	125	170	100	125	
Single fixing cracked and non-cracked concrete								
Approved loads, tension	C20/25	$\Delta N_{appr.}$	[kN]	14,8	25,5	31,9	15,7	22,4
Approved loads, shear	C20/25	$\Delta N_{appr.}$	[kN]	6,1	11,1	15,6	6,1	11,1
Multiple use (per anchor) cracked and non-cracked concrete								
Approved loads, tension	C20/25	$\Delta N_{appr.}$	[kN]	11,4	19,4	24,5	12,7	21,1
Approved loads, shear	C20/25	$\Delta N_{appr.}$	[kN]	4,7	8,5	12,0	4,7	8,5
Spacing and edge distance								
Characteristic spacing	$s_{cr,N}$	[mm]	300	375	510	300	375	
Characteristic edge distance	$c_{cr,N}$	[mm]	150	187,5	255	150	187,5	
Minimum spacing	s_{min}	[mm]	50 (80) ²⁾	60	80	50 (80) ²⁾	60	
Minimum edge distance	c_{min}	[mm]	70 (75) ²⁾	80	110	70 (75) ²⁾	80	
Minimum thickness of concrete slab	h_{min}	[mm]	130	170	230	130	170	
Installation parameters								
Drill hole diameter	d_o	[mm]	14	18	24	14	18	
Depth of drill hole ³⁾	h_o	[mm]	105	133	180	105	133	
Diameter of clearance hole in the fixture	d_f	[mm]	15	19	25	15	19	
Installation torque	T_{inst}	[Nm]	30	50	80	30	50	
Width across nut	SW	[mm]	18	24	30	18	24	
Minimum thickness of fixture	$t_{fix} \geq$	[mm]	12	16	20	12	16	

¹⁾ Max. long term temperature +50 °C / max. short term temperature +80 °C .

²⁾ Values in brackets are for non-cracked concrete.

³⁾ If the maximum fixture thickness t_{fix} is not completely used, the depth of drill hole and the setting depth of the anchor have to be increased accordingly.

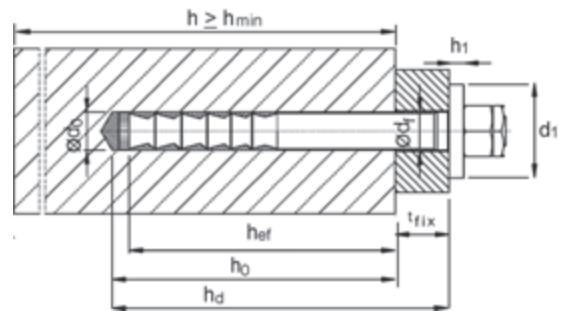

For anchor designing, an easy to operate Software is available on request or can be downloaded at www.mkt.de
Amount of adhesive per anchor see page 94/95.

Curing Time Injection Adhesive VMZ

→ Cartridge temperature when installing min. +5°C

Temperature (°C) of the base material	Gel time	Curing time	
		dry base material	wet base material
-5°C	1:30 h	6:00 h	12:00 h ¹⁾
-4°C bis -1°C	45 min	6:00 h	12:00 h ¹⁾
0°C bis +4°C	20 min	3:00 h	6:00 h
+5°C bis +9°C	12 min	2:00 h	4:00 h
+10°C bis +19°C	6 min	1:20 h	2:40 h
+20°C bis +29°C	4 min	45 min	1:30 h
+30°C bis +34°C	2 min	25 min	50 min
+35°C bis +39°C	1,4 min	20 min	40 min
+40°C	1,4 min	15 min	30 min

¹⁾ It must be ensured that icing does not occur in the drill hole. The hole must be cleaned directly prior to the installation of the anchor.

Curing Time Injection Adhesive VMZ express

→ Cartridge temperature when installing min. +5°C

Temperature (°C) of the base material	Gel time	Curing time	
		dry base material	wet base material
-5°C	40 min	4:00 h	8:00 h ¹⁾
-4°C bis -1°C	20 min	4:00 h	8:00 h ¹⁾
0°C bis +4°C	10 min	2:00 h	4:00 h
+5°C bis +9°C	6 min	1:00 h	2:00 h
+10°C bis +19°C	3 min	40 min	80 min
+20°C bis +29°C	1 min	20 min	40 min
+30°C	1 min	10 min	20 min

¹⁾ It must be ensured that icing does not occur in the drill hole. The hole must be cleaned directly prior to the installation of the anchor.

Installation

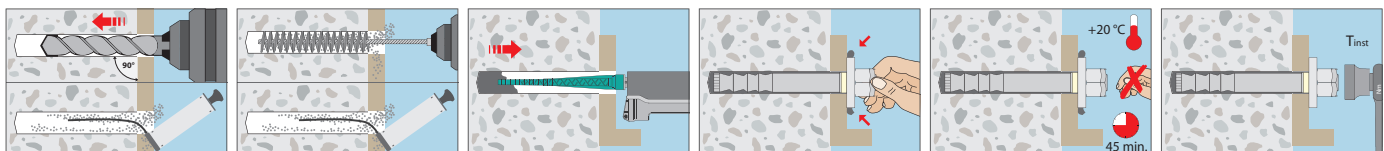

Cleaning Brush RB M6



RB M6, with connection thread M6



RBL M6, with internal and external thread M6



RBL M6 SDS, with internal thread M6

- With connection thread M6 – extension for large depths of drill hole and/or for through-setting installation
- For drilling machines with keyed chuck or with SDS adaptor for SDS plus drill holders

Description	Ref. No.	Suitable for drill hole Ø mm	Total length of brush mm	VMZ-A	Suitable for VMZ-A dyn	VMZ-IG	Pkg. cont. pcs.	Weight per piece kg
RB 10 M6	33510101	10	130	M8	-	M6	1	0,05
RB 12 M6	33512101	12	140	M10, 75 M12	-	M8	1	0,05
RB 14 M6	33514101	14	180	M12	M12	M10	1	0,05
RB 18 M6	33518101	18	200	M16	M16	M12	1	0,05
RB 22 M6	33522101	22	220	115 M20	-	115 M16	1	0,05
RB 24 M6	33524101	24	250	M20	M20	M16	1	0,06
RB 26 M6	33526101	26	290	M24	-	M20	1	0,06
RBL M6	33968101	Brush extension 150mm with connection thread M6					1	0,09
RBL M6 SDS	33350101	SDS Plus adapter with internal thread M6					1	0,06

Blow-out pump VM-AP



- For approval-compliant air-cleaning of drill holes with a diameter up to 18 mm (VMZ)
- For best drill hole cleaning, the hose must reach the bottom of the drill hole

Description	Ref. No.	Hose Ø mm	For drill hole Ø mm	Max. drill hole depth ¹⁾ mm	Pkg. cont. pcs.	Weight per piece kg
VM-AP 360, blow-out pump	33200101	8	8 ¹⁾ -20	330	1	0,27

¹⁾With extension tube Ø 6 x 100mm
²⁾For through fastening: Maximum drill hole depth through fixture

Air gun VM-ABP



- For approval-compliant drill hole cleaning with compressed air for drill holes with a diameter larger than 6 mm
- For best drill hole cleaning, the nozzle of the air gun must reach the bottom of the drill hole

Description	Ref. No.	Nozzle-Ø mm	For drill hole Ø mm	Max. drill hole depth ¹⁾ mm	Pkg. cont. pcs.	Weight per piece kg
VM-ABP 200	33090101	5	6-20	240	1	0,55
VM-ABP 250	33100101	16	18-40	240	1	1,00
VM-ABP 500	33106101	16	18-40	480	1	1,30

¹⁾For through fastening: Maximum drill hole depth through fixture

Dispenser VM-P Profi



- Professional dispenser with an ideal center of gravity for more comfortable working
- Automatic pressure release for minimum adhesive overrun

Description	Ref. No.	Suitable for cartridge	Pkg. cont. pcs.	Weight per piece kg
VM-P 345 Profi	28350511	150ml, 280ml, 300ml, 345ml also suitable for silicone cartridges	1	1,00
VM-P 380 Profi	28351001	380ml, 410ml, 420ml	1	1,10

Dispenser VM-P Standard



- For occasional use, metal version
- Piston rod with adjusting screw

Description	Ref. No.	Suitable for cartridge	Pkg. cont. pcs.	Weight per piece kg
VM-P 345 Standard	28350505	150ml, 280ml, 300ml, 345ml also suitable for silicone cartridges	1	1,00
VM-P 380 Standard	28353005	380ml, 410ml, 420ml	1	1,15

Dispenser VM-P Pneumatic



- Professional air tool with an optimum center of gravity and quick cartridge exchange
- Automatic pressure release system reduces adhesive overrun to a minimum
- Single-hand pressure regulation to adjust the piston speed
- With compressed air connection nipple

Description	Ref. No.	Suitable for cartridge	Pkg. cont. pcs.	Weight per piece kg
VM-P 345 Pneumatic	28350601	345ml max. working pressure 8bar, 40l/min	1	2,41
VM-P 380 Pneumatic	28352002	380ml, 410ml, 420ml max. working pressure 8bar, 40l/min	1	2,00

NEW

Chemical Anchors

Injection System VMH



Threaded stud V-A



Threaded stud VMU-A



Threaded stud VM-A
1 meter length, to be cut to the required length

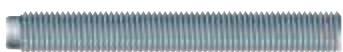

Internally threaded sleeve VMU-IG



NEW



Cartridge VMH 280
Coaxial cartridge suitable for silicone guns
Content: 280ml including 2 mixers

NEW



Cartridge VMH 345
Side-by-side cartridge
Content: 345ml

NEW



Cartridge VMH 420
Coaxial cartridge
Content: 420ml

Range of loading: 3,9 kN – 221,6 kN

Concrete quality: C20/25 - C50/60

Material: Steel zinc plated, hot dip galvanized, stainless steel A4, stainless steel HCR

Description

The Injection System VMH is a universal injection system for heavy duty fastenings, usable in cracked and non-cracked concrete. It is composed of a hybrid injection adhesive as well as a threaded stud V-A, a threaded stud VMU-A, or an internally threaded sleeve VMU-IG. A standard threaded stud with strength test certificate 3.1 or a rebar can also be used. The variable anchorage depths allow for a perfect adjustment to the respective installation situation, even under seismic action.

Advantages

- Extremely high loads in cracked and non-cracked concrete, strength class C20/25 to C50/60
- Approved with threaded studs V-A, VMU-A, standard threaded studs with strength test certificate and internally threaded sleeves VMU-IG, thus more flexibility in the choice of the fastening
- Variable anchorage depths allow perfect adjustment to the respective installation situation for an economic working process
- Approved for use under seismic action according to the performance categories C1 (Threaded studs M8 – M30, Reinforcement Bars Ø8 – Ø32) and C2 (Threaded studs M12 Steel, zinc plated 8.8, M12 A4, M12 HCR)
- Due to the high short-term temperature resistance up to +160°C, also suitable for fastenings exposed to high temperature
- Approved for installation in wet concrete
- Base material temperature during installation -5°C to +40°C
- Opened cartridges can be re-used with a new mixer nozzle
- Styrene free

Applications

Heavy duty fastenings in cracked and non-cracked concrete:

Steel structures, railings, base plates, supports, brackets, facade structures.

Fastenings with rebar in cracked and non-cracked concrete with shear force: Shear connectors, wall connecting reinforcement, concrete overlay.

Injection Cartridge VMH



- Hybrid injection adhesive, styrene free
- Approved for cracked and non-cracked concrete as well as post-installed rebar

Description	Ref. No.	Content ml	Content of master box	Weight per master box kg	Weight per piece kg
Cartridge VMH 280 ¹⁾	28251501	280	12	6,70	0,56
Cartridge VMH 345	28253501	345	12	8,00	0,65
Cartridge VMH 420	28257501	420	12	10,1	0,83
Static mixer VM-XH	28304801	-	12	0,16	0,01

One static mixer comes with each cartridge.
¹⁾Cartridge VMH 280 comes with 2 mixers.

Mixer extensions



- Extension tubes for deeper drill holes

VM-XE 10

Description	Ref. No.	Diameter mm	Length mm	Package content Pcs.	Weight per pkg. kg
VM-XE 10/200	28306011	200	10	12	0,12
VM-XE 10/500	85951101	500	10	10	0,20
VM-XE 10/1000	85952101	1000	10	10	0,30

Curing Time Injection Adhesive VMH

- Cartridge temperature when installing + 5°C to + 40°C

Temperature (°C) of the base material	Gel time	Curing time	
		Dry base material	Wet base material
-5°C to - 1°C	50 min	5 h	10 h
0°C to + 4°C	25 min	3,5 h	7 h
+ 5°C to + 9°C	15 min	2 h	4 h
+ 10°C to + 14°C	10 min	1 h	2 h
+ 15°C to + 19°C	6 min	40 min	80 min
+ 20°C to + 29°C	3 min	30 min	60 min
+ 30°C to + 40°C	2 min	30 min	60 min

Threaded studs for use in cracked and non-cracked concrete

Threaded Stud VMU-A

Steel, zinc plated 5.8
 Dimensions see page 107



- For use in structures subject to dry internal conditions
- Steel, zinc plated 8.8 on demand

Threaded Stud VMU-A A4

Stainless steel A4
 Dimensions see page 107



- For use in structures subject to dry internal conditions or external atmospheric exposure
- Stainless steel HCR on demand

Internally Threaded Sleeve VMU-IG

Steel, zinc plated 5.8
 Dimensions see page 108



- For use in structures subject to dry internal conditions
- With internal thread

Internally Threaded Sleeve VMU-IG A4

Stainless steel A4
 Dimensions see page 108



- For use in structures subject to dry internal conditions or external atmospheric exposure
- With internal thread

Threaded Stud V-A

Steel, zinc plated 5.8
 Dimensions see page 144



- For use in structures subject to dry internal conditions
- Steel, zinc plated 8.8 on demand

Threaded Stud V-A A4

Stainless steel A4
 Dimensions see page 144



- For use in structures subject to dry internal conditions or external atmospheric exposure

Threaded Stud V-A fzv

Steel, hot dip galvanized 5.8
 Dimensions see page 144



- For use in structures subject to dry internal conditions
- Steel hot dip galvanized 8.8 on demand

Threaded Stud V-A HCR

Stainless steel HCR
 Dimensions see page 144



- For use in particularly corrosive environments
- High corrosion resistant steel 1.4529 (HCR)

Threaded stud VM-A

Steel 5.8, zinc plated
 Dimensions see page 108



- For use in structures subject to dry internal conditions
- Threaded studs, of 1 meter length, to be cut to the required length
- Comes with manufacturer's certificate (3.1 EN 10204) in every package

Threaded stud VM-A

Stainless steel A4
 Dimensions see page 108



- For use in structures subject to dry internal conditions or external atmospheric exposure
- Threaded studs, of 1 meter length, to be cut to the required length
- Comes with manufacturer's certificate (3.1 EN 10204) in every package

Threaded stud VM-A

Steel 8.8, zinc plated
 Dimensions see page 108



- For use in structures subject to dry internal conditions
- Threaded studs, of 1 meter length, to be cut to the required length
- Comes with manufacturer's certificate (3.1 EN 10204) in every package

Drill Hole Cleaning

Cleaning Brush RB M6



- With connection thread M6
- Extension for large depths of drill hole
- Separate SDS plus adapter with internal thread M6 for SDS plus socket
- For drilling machines with keyed chuck

Description	Ref. No.	Suitable for drill hole Ø mm	Total length of brush mm	Suitable for			Package content pcs.	Weight per pkg. kg
				Threaded stud	Internally threaded sleeve VMU-IG	Rebar		
RB 10 M6	33510101	10	130	M8			1	0,05
RB 12 M6	33512101	12	140	M10	IG M6	Ø 8	1	0,05
RB 14 M6	33514101	14	180	M12	IG M8	Ø 10	1	0,05
RB 16 M6	33516101	16	200	-	-	Ø12	1	0,05
RB 18 M6	33518101	18	200	M16	IG M10	-	1	0,05
RB 20 M6	33520101	20	220	-	-	Ø 16	1	0,05
RB 22 M6	33522101	22	220	M20	IG M12	-	1	0,06
RB 26 M6	33526101	25/26	250	-	-	Ø 20	1	0,06
RB 28 M6	33528101	28	260	M24	IG M16	-	1	0,06
RB 32 M6	33532101	32	350	-	-	Ø 25	1	0,08
RB 35 M6	33535101	35	350	M30	IG M20	Ø 28	1	0,08
RB 40 M6	33537101	40	350	-	-	Ø 32	1	0,08
RBL M6	33968101	Brush extension 150 mm with connection thread M6					1	0,09
RBL M6 SDS	33350101	SDS Plus adapter for cleaning brushes (M6)					1	0,06

Retaining Washer VM-IA



- For bubble-free filling of the drill hole
- Fits to extension tubes VM-XLE 10 and VM-XLE 16

Description	Ref. No.	Suitable for drill hole Ø mm	Colour	Suitable for			Package content Pcs.	Weight per pkg. kg
				Threaded stud	Internally threaded sleeve VMU-IG	Rebar		
VM-IA 18	85918201	18	black	M16	IG M10	Ø 14	20	0,02
VM-IA 20	85920201	20	black	-	-	Ø 16	20	0,06
NEW VM-IA 22	85922201	22	black	M20	IG M12	-	20	0,06
VM-IA 25	85925201	25	black	-	-	Ø 20	20	0,06
VM-IA 28	85928101	28	black	M24	IG M16	-	20	0,08
VM-IA 32	85932201	32	black	-	-	Ø 25	20	0,08
VM-IA 35	85935201	35	black	M30	IG M20	Ø 28	20	0,08
VM-IA 40	85938201	40	black	-	-	Ø 32	20	0,08

Blow-out pump VM-AP



- For approval-compliant air-cleaning of drill holes in non-cracked concrete with a diameter up to 20 mm and a drill hole depth at most ten times larger than the diameter of the threaded stud (VMH)
- For best drill hole cleaning, the hose must reach the bottom of the drill hole

Description	Ref. No.	Hose Ø mm	For drill hole Ø mm	Max. drill hole depth ¹⁾ mm	Pkg. cont. pcs	Weight per piece kg
Blow-out pump VM-AP 360	33200101	8	8 ¹⁾ -20	330	1	0,27

¹⁾With extension tube Ø 6 x 100mm

²⁾For through fastening: Maximum drill hole depth through fixture

Air gun VM-ABP



- For approval-compliant drill hole cleaning with compressed air for drill holes with a diameter larger than 6 mm
- For best drill hole cleaning, the nozzle of the air gun must reach the bottom of the drill hole

Description	Ref. No.	Nozzle-Ø mm	For drill hole Ø mm	Max. drill hole depth ¹⁾ mm	Pkg. cont. pcs.	Weight per piece kg
NEW VM-ABP 200	33090101	5	6-20	240	1	0,55
VM-ABP 250	33100101	16	18-40	240	1	1,00
VM-ABP 500	33106101	16	18-40	480	1	1,30

¹⁾For through fastening: Maximum drill hole depth through fixture

Air gun VM-ABP



→ Drill hole cleaning with compressed air for holes up to one meter

→ For best drill hole cleaning the nozzle of the air-gun must reach to the bottom of the drill hole

Description	Ref. No.	Nozzle Ø mm	Max. Drill hole depth mm	For drill hole Ø mm	Pkg. cont. pcs	Weight per piece kg
VM-ABP 1000	85806101	14	1000	16-40	1	0,32

Dispenser VM-P Profi



→ Professional dispenser with an ideal center of gravity for more comfortable working

→ Automatic pressure release for minimum adhesive overrun

Description	Ref. No.	Suitable for cartridge	Pkg. cont. pcs	Weight per piece kg
VM-P 345 Profi	28350511	150ml, 280ml, 300ml, 345ml also suitable for silicone cartridges	1	1,00
VM-P 380 Profi	28351001	380ml, 410ml, 420ml	1	1,10

Dispenser VM-P Standard



→ For occasional use, metal version

→ Piston rod with adjusting screw

Description	Ref. No.	Suitable for cartridge	Pkg. cont. pcs	Weight per piece kg
VM-P 345 Standard	28350505	150ml, 280ml, 300ml, 345ml also suitable for silicone cartridges	1	1,00
VM-P 380 Standard	28353005	380ml, 410ml, 420ml	1	1,15

Dispenser VM-P Pneumatic



→ Professional air tool with an optimum center of gravity and quick cartridge exchange

→ Automatic pressure release system reduces adhesive overrun to a minimum

→ Single-hand pressure regulation to adjust the piston speed

→ With compressed air connection nipple

Description	Ref. No.	Suitable for cartridge	max. working pressure	Pkg. cont. pcs	Weight per piece kg
VM-P 345 Pneumatic	28350601	280ml, 300ml, 345ml	8 bar, 40l/min	1	2,41
VM-P 380 Pneumatic	28352002	380ml, 410ml, 420ml	8 bar, 40l/min	1	2,00

Auspresspistolen VM-P Akku



¹⁾ with Akku 18V/2,0 Ah

→ Professional, solid battery cartridge dispenser in a plastic case

→ Repeat function, for retrieving the last fill quantity

→ Stepless variable pressing speed

→ Overrun-quantity-stop by automatic return after release of the dispensing switch

Description	Ref. No.	Suitable for cartridge	Press-out force kN	Weight ¹⁾ kg	Dimensions ¹⁾ L x B x H mm	Pkg. cont. pcs	Weight per piece kg
VM-P 345 Akku	28350801	345ml	5,0	3,53	395 x 180 x 285	1	7,72
VM-P 380 Akku	28352601	380ml, 410ml, 420ml	3,95	3,62	375 x 180 x 285	1	7,80
Accessories (for all models)							
Replacement battery	28352411			18 V/2,0 Ah		1	1,00
Shoulder strap	28359991			adjustable		1	0,02



Extract from Permissible Service Conditions of European Technical Assessment ETA-17/0716

Approved loads without influence of spacing and edge distance in dry or wet concrete for temperature range I -40°C to +50°C/+80°C¹⁾ (Approved loads for temperature range II -40°C to +72°C/+120°C¹⁾ and III -40°C to +100°C/+160°C¹⁾ please see ETA-17/0716). Total safety factor as per ETAG included (γ_M and γ_F). Load capacities under fire exposure see page 168.

Loads and performance data

Range of temperature I -40°C to +50°C/+80°C¹⁾

Threaded studs			M8	M10	M12	M16	M20	M24	M27	M30	
Range of anchorage depths $h_{ef,min} - h_{ef,max}$		[mm]	60 - 160	60 - 200	70 - 240	80 - 320	90 - 400	96 - 480	108 - 540	120 - 600	
Injection System VMH, threaded stud steel 5.8											
Approved loads, tension for $h_{ef,min} - h_{ef,max}$											
Cracked concrete	C20/25	appr. N	[kN]	3,9 - 8,6	5,2 - 13,8	7,9 - 20,0	10,2 - 37,1	12,2 - 58,1	13,4 - 83,8	16,0 - 109,5	18,8 - 133,3
Non-cracked concrete	C20/25	appr. N	[kN]	8,6	9,3 - 13,8	11,7 - 20,0	14,3 - 37,1	17,1 - 58,1	18,8 - 83,8	22,5 - 109,5	26,3 - 133,3
Approved loads, shear for $h_{ef,min} - h_{ef,max}$											
Cracked concrete	C20/25	appr. V	[kN]	5,1	8,6	12,0	22,3	29,3 - 34,9	32,2 - 50,3	38,5 - 65,7	45,1 - 80,0
Non-cracked concrete	C20/25	appr. V	[kN]	5,1	8,6	12,0	22,3	34,9	45,2 - 50,3	54,0 - 65,7	63,2 - 80,0
Injection System VMH, threaded stud steel 8.8											
Approved loads, tension for $h_{ef,min} - h_{ef,max}$											
Cracked concrete	C20/25	appr. N	[kN]	3,9 - 10,4	5,2 - 17,5	7,9 - 26,9	10,2 - 54,3	12,2 - 84,8	13,4 - 122,1	16,0 - 154,5	18,8 - 190,7
Non-cracked concrete	C20/25	appr. N	[kN]	9,3 - 13,8	9,3 - 21,9	11,7 - 31,9	14,3 - 59,5	17,1 - 93,3	18,8 - 134,3	22,5 - 175,2	26,3 - 213,8
Approved loads, shear for $h_{ef,min} - h_{ef,max}$											
Cracked concrete	C20/25	appr. V	[kN]	8,6	12,6 - 13,1	18,8 - 19,4	24,5 - 36,0	29,3 - 56,0	32,2 - 80,6	38,5 - 105,1	45,1 - 128,0
Non-cracked concrete	C20/25	appr. V	[kN]	8,6	13,1	19,4	34,4 - 36,0	41,1 - 56,0	45,2 - 80,6	54,0 - 105,1	63,2 - 128,0
Injection System VMH, threaded stud stainless steel A4, HCR											
Approved loads, tension for $h_{ef,min} - h_{ef,max}$											
Cracked concrete	C20/25	appr. N	[kN]	3,9 - 9,9	5,2 - 16,0	7,9 - 22,5	10,2 - 42,0	12,2 - 65,3	13,4 - 94,3	16,0 - 57,4	18,8 - 70,2
Non-cracked concrete	C20/25	appr. N	[kN]	9,3 - 9,9	9,3 - 16,0	11,7 - 22,5	14,3 - 42,0	17,1 - 65,3	18,8 - 94,3	22,5 - 57,4	26,3 - 70,2
Approved loads, shear for $h_{ef,min} - h_{ef,max}$											
Cracked concrete	C20/25	appr. V	[kN]	6,0	9,2	13,7	24,5 - 25,2	29,3 - 39,4	32,2 - 56,8	34,5	42,0
Non-cracked concrete	C20/25	appr. V	[kN]	6,0	9,2	13,7	25,2	39,4	45,2 - 56,8	34,5	42,0
Spacing and edge distance											
Min. thickness of concrete slab for $h_{ef,min} - h_{ef,max}$	h_{min}	[mm]		100 - 190	100 - 230	100 - 270	116 - 356	134 - 444	152 - 536	168 - 600	190 - 670
Minimum spacing	s_{min}	[mm]		40	50	60	75	95	115	125	140
Minimum edge distance	c_{min}	[mm]		35	40	45	50	60	65	75	80
Installation parameters											
Drill hole diameter	d_o	[mm]		10	12	14	18	22	28	30	35
Clearance hole in the fixture	$d_{r \leq}$	[mm]		9	12	14	18	22	26	30	33
Range of drill hole depth for $h_{ef,min} - h_{ef,max}$	h_o	[mm]		60 - 160	60 - 200	70 - 240	80 - 320	90 - 400	96 - 480	108 - 540	120 - 600
Installation torque	$T_{inst \leq}$	[Nm]		10	20	40	60	100	170	250	300
Amount of adhesive per 100mm drill hole depth	[ml]			6,53	8,16	9,82	13,61	17,89	32,25	30,69	48,70

¹⁾Max. long term temperature/max. short term temperature

Higher concrete strength may lead to higher approved loads. Technical data see European Technical Assessment. For anchor designing, an easy to operate Software is available on request or can be downloaded at www.mkt.de.

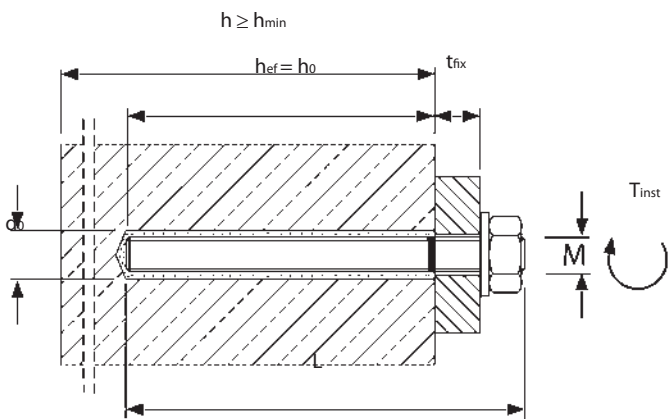

Installation threaded stud in concrete

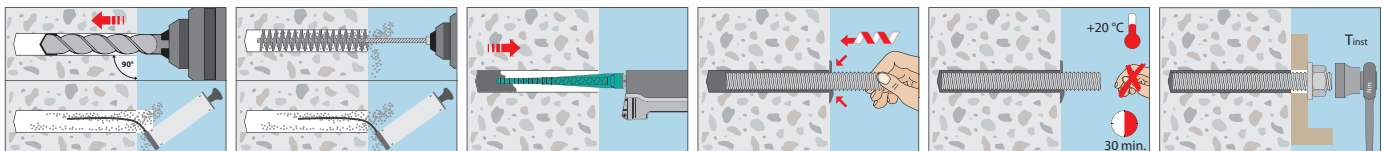



Extract from Permissible Service Conditions of European Technical Assessment ETA-17/0716

Approved loads without influence of spacing and edge distance in dry or wet concrete for temperature range I -40°C to + 50°C/+80°C¹⁾ (Approved loads for temperature range II -40°C to +72°C/+ 120°C¹⁾ and III -40°C to +100°C/+ 160°C please see ETA-17/0716).

Total safety factor as per ETAG included (γ_M and γ_F).

Loads and performance data				Range of temperature I -40°C bis + 50°C/+80°C ¹⁾								
Internally threaded sleeves				IG M6 x 80	IG M6 x 90	IG M8 x 80	IG M8 x 100	IG M10 x 80	IG M10 x 100	IG M12 x 125	IG M16 x 170	IG M20 x 200
Anchorage depth h_{ef}		[mm]		80	90	80	100	80	100	125	170	200
Injection System VMH, internally threaded sleeve VMU-IG steel 5.8												
Approved loads, tension for h_{ef}												
Cracked concrete	C20/25	appr. N	[kN]	4,8	4,8	8,6	8,6	10,2	13,8	20,0	31,7	40,4
Non-cracked concrete	C20/25	appr. N	[kN]	4,8	4,8	8,6	8,6	13,8	13,8	20,0	37,6	56,7
Approved loads, shear for h_{ef}												
Cracked concrete	C20/25	appr. V	[kN]	2,9	2,9	5,1	5,1	8,6	8,6	12,0	22,3	34,9
Non-cracked concrete	C20/25	appr. V	[kN]	2,9	2,9	5,1	5,1	8,6	8,6	12,0	22,3	34,9
Injection System VMH, internally threaded sleeve VMU-IG stainless steel A4, HCR												
Approved loads, tension for h_{ef}												
Cracked concrete	C20/25	appr. N	[kN]	5,3	5,3	9,0	9,9	10,2	14,3	20,0	31,7	31,0
Non-cracked concrete	C20/25	appr. N	[kN]	5,3	5,3	9,9	9,9	14,3	15,7	22,5	42,0	31,0
Approved loads, shear for h_{ef}												
Cracked concrete	C20/25	appr. V	[kN]	3,2	3,2	6,0	6,0	9,2	9,2	13,7	25,2	18,6
Non-cracked concrete	C20/25	appr. V	[kN]	3,2	3,2	6,0	6,0	9,2	9,2	13,7	25,2	18,6
Spacing and edge distance												
Min. thickness of concrete slab for h_{ef}	h_{min}	[mm]		110	120	110	130	116	136	169	226	270
Minimum spacing	s_{min}	[mm]		50	50	60	60	75	75	95	115	140
Minimum edge distance	c_{min}	[mm]		40	40	45	45	50	50	60	65	80
Installation parameters												
Drill hole diameter	d_o	[mm]		12	12	14	14	18	18	22	28	35
Clearance hole in the fixture	$d_f \leq$	[mm]		7	7	9	9	12	12	14	18	22
Range of drill hole depth for h_{ef}	h_o	[mm]		80	90	80	100	80	100	125	170	200
Installation torque	$T_{inst} \leq$	[Nm]		10	10	10	10	20	20	40	60	100
Amount of adhesive per drill hole		[ml]		6,6	7,4	7,9	9,9	10,9	13,6	22,4	54,9	97,4

¹⁾Max. long term temperature/max. short term temperature

Higher concrete strength may lead to higher approved loads. Technical data see European Technical Assessment.

For anchor designing, an easy to operate Software is available on request or can be downloaded at www.mkt.de.

Loads and performance data				Range of temperature I -40°C bis + 50°C/+80°C ¹⁾								
Injection System VMH, rebar B500B				Ø8	Ø10	Ø12	Ø14	Ø16	Ø20	Ø25	Ø28	Ø32
Range of anchorage depths $h_{ef,min} - h_{ef,max}$		[mm]		60 – 160	60 – 200	70 – 240	75 – 280	80 – 320	90 – 400	100 – 500	112 – 560	128 – 640
Approved loads, tension for $h_{ef,min} - h_{ef,max}$												
Cracked concrete	C20/25	appr. N	[kN]	3,0 – 8,0	4,1 – 13,7	6,3 – 21,5	7,9 – 29,3	10,2 – 47,9	12,2 – 74,8	14,3 – 116,9	16,9 – 146,6	20,7 – 204,3
Non-cracked concrete	C20/25	appr. N	[kN]	8,4 – 13,8	9,3 – 21,6	11,7 – 31,2	13,0 – 42,4	14,3 – 55,4	17,1 – 86,6	20,0 – 135,2	23,8 – 169,6	29,0 – 221,6
Approved loads, shear for $h_{ef,min} - h_{ef,max}$												
Cracked concrete	C20/25	appr. V	[kN]	6,5	9,9 – 10,1	14,5	18,8 – 19,8	24,5 – 25,9	29,3 – 40,4	34,3 – 63,1	40,6 – 79,2	49,7 – 103,4
Non-cracked concrete	C20/25	appr. V	[kN]	6,5	10,1	14,5	19,8	25,9	40,4	48,1 – 63,1	57,0 – 79,2	69,6 – 103,4
Spacing and edge distance												
Min. thickness of concrete slab for $h_{ef,min} - h_{ef,max}$	h_{min}	[mm]		100 – 190	100 – 230	102 – 272	111 – 316	120 – 360	140 – 450	164 – 564	182 – 630	208 – 720
Minimum spacing	s_{min}	[mm]		40	50	60	70	75	95	120	130	150
Minimum edge distance	c_{min}	[mm]		35	40	45	50	50	60	70	75	85
Installation parameters												
Drill hole diameter	d_o	[mm]		12	14	16	18	20	25	32	35	40
Range of drill hole depth for $h_{ef,min} - h_{ef,max}$	h_o	[mm]		60 – 160	60 – 200	70 – 240	75 – 280	80 – 320	90 – 400	100 – 500	112 – 560	128 – 640
Amount of adhesive per 100mm drill hole depth		[ml]		7,6	9,1	10,6	25,5	13,6	21,2	37,6	41,6	54,3

¹⁾Max. long term temperature/max. short term temperature

Higher concrete strength may lead to higher approved loads. Technical data see European Technical Assessment.

For anchor designing, an easy to operate Software is available on request or can be downloaded at www.mkt.de.

Injection System VMU plus

 **Threaded Stud VMU-A**
for concrete and brickwork

 **Threaded Stud VM-A**
1 meter length, to be cut to the required length
for concrete and brickwork

 **Internally Threaded Sleeve VMU-IG**
for concrete and brickwork

 **Perfo Sleeve VM-SH**
for perforated brick

 **Cartridge VMU plus 150**
Coaxial cartridge
suitable for silicone guns
Content: 150ml

 **Cartridge VMU plus 280**
Coaxial cartridge
suitable for silicone guns
Content: 280ml, including
2 mixers, attached to the
cartridge

 **Cartridge VMU plus 300**
Foil tube cartridge
suitable for silicone guns
Content: 300 ml

 **Cartridge VMU plus 345**
Side-by-side cartridge
Content: 345ml

 **Cartridge VMU plus 410**
Coaxial cartridge
Content: 410ml



Range of loading: 0,3 kN – 202,0 kN

Concrete quality: C20/25 - C50/60

Brickwork: Solid and perforated brick

Material: Steel zinc plated, hot dip galvanized, Stainless steel A4/316, Stainless steel HCR

Description

The injection system VMU plus is a universal injection system for almost all applications and materials. Besides the use in non-cracked concrete and masonry, VMU plus is also approved for fixings in cracked concrete and for post installed rebar connections¹⁾. The new European Technical Assessment ETA-13/0909 includes 6 sizes of perforated sleeves up to 200 mm length and is approved in 15 different types of bricks. To complete the fastening, various anchor rods or internal sleeves can be used from the existing MKT-range (VMU-A, VMU-IG, VM-A and V-A), as well as standard threaded rods or reinforcing bars. In perforated brick, a perfo sleeve is required.

Advantages

- Only one adhesive for almost all applications, more flexibility, less inventory, greater application safety
- Approved for cracked and non-cracked concrete
- Approved for post-installed rebar connections (Ø8-Ø32)¹⁾
- Approved application in wet or water-filled drill holes (M8-M16)
- Approved for autoclaved aerated concrete, solid and perforated brickwork
- Approved with standard threaded studs (test certificate required)
- Base material temperature during installation -10°C (concrete) to +40°C
- Ambient temperature when completely cured -40°C to +120°C (concrete)
- Variable anchorage depth for less drilling efforts
- Fire test report
- Opened cartridges can be re-used with a new mixer nozzle
- Styrene-free vinylester resin
- Approved for use under seismic action according to the performance category C1

¹⁾only with Coaxial- and Side-by-side VMU plus cartridge

**Cartridge****VMU plus 825**

Side-by-side cartridge
Content: 825 ml
With big mixer VM-XL
and reducer / extension
tube for drill holes down
to 12mm diameter

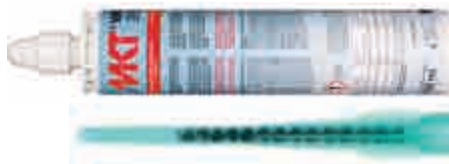
**Cartridge****VMU plus 300 Polar**

Foil tube cartridge
suitable for silicone guns
Content: 300 ml

**Cartridge****VMU plus 345 Polar**

Side-by-side cartridge
Content: 345 ml

**Cartridge****VMU plus 420 Polar**

Coaxial cartridge
Content: 420 ml

**Additional advantages VMU plus Polar**

- Fast and reliable curing even at low temperatures and minus degrees
- Approved for cracked and non-cracked concrete as well as masonry even at icy -20 °C
- Approved temperature range from + 10 °C to -20 °C for base material and cartridge. Heating and keeping the cartridge warm before installation is not necessary.
- The same European Technical Assessments (ETA-11/0415 and ETA-13/0909) for VMU plus and VMU plus Polar; therefore the Installation is possible from + 40 °C to -20 °C temperature without recalculation of the application.

**Applications****Fastenings in cracked and non-cracked concrete:**

Base plates, supports, mounting of joint tapes, shelves, brackets, railings, facade substructures, wooden structures, cable trays, etc.

Fastenings with rebars in cracked and non-cracked concrete - with shear forces:

Shear connectors, wall connecting reinforcement, concrete overlay

Post-installed rebar connections¹⁾:

Ceiling and wall connections, structural reinforcement, structural complement building extensions, connection of balconies and canopies, subsequent attaching of „forgotten or misplaced“ reinforcing bars

Fastenings in Brickwork:

Canopies, door and window frames, facade substructures, battens, gates etc.

¹⁾only with Coaxial- and Side-by-side VMU plus cartridge

Injection Cartridge VMU plus



- Two component cartridge, styrene-free
- Approved for non-cracked concrete and brickwork

Description	Ref. No.	Content ml	Cont. of master box pcs	Weight per master box kg	Weight per piece kg
Cartridge VMU plus 150	28255271	150	12	4,20	0,34
Cartridge VMU plus 280 ¹⁾	28252401	280	12	6,70	0,56
Cartridge VMU plus 300	28255126	300	12	6,40	0,53
Cartridge VMU plus 300 Polar	28252901	300	12	6,40	0,53
Cartridge VMU plus 345	28254001	345	12	8,00	0,65
Cartridge VMU plus 345 Polar	28253901	345	12	8,00	0,65
Cartridge VMU plus 410	28256041	410	12	10,1	0,83
Cartridge VMU plus 420 Polar	28257121	420	12	10,1	0,83
Cartridge VMU plus 825	28259001	825	8	13,0	1,63
Static mixer VM-X	28305111	-	12	0,12	0,01
Static mixer VM-XL ²⁾	28305201	-	10	0,28	0,03
Mixer extension VM-XE 10/200 (200mm)	28306011	-	12	-	0,01
Mixer extension VM-XE 10/500 (500mm)	85951101	-	10	0,02	0,02

One static mixer VM-X as well as one screw-on cap comes with each cartridge. (VMU plus 825: VM-XL). Usable length of static mixer see below, Extension tubes see page 110.

¹⁾Cartridge VMU plus 280 comes with 2 mixers.

²⁾With larger cross section for larger drill holes or post-installed rebar connections.

Usable length Static mixer VM-X/VM-XP

Drill holes must always be filled from the bottom of the hole to ensure no air pockets are trapped in the adhesive. This is only possible when the tip of the mixing nozzle reaches the very bottom of the drill hole before injecting the adhesive. If the mixing nozzle does not reach the bottom of the drill hole, a mixer extension tube must be used.

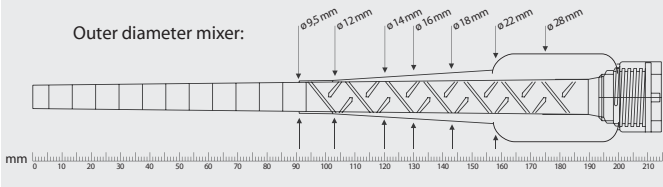

Storage Box

- In stackable multi-purpose container
- Storage box, the container for various items

Description	Ref. No.	Contents	Quantity pcs.	Weight per Box kg
Storage box VMU plus 280	28999148	Cartridge VMU plus 280 Static mixer VM-X	20 40	12,8
Storage box VMU plus 345	28999640	Cartridge VMU plus 345 Static mixer VM-X	20 40	15,3
Storage box VMU plus 345 Polar	28999670	Cartridge VMU plus 345 Polar Static mixer VM-X	20 40	15,3
Storage box VMU plus 410	28999652	Cartridge VMU plus 410 Static mixer VM-X	20 40	18,0

Dimensions storage box

Description	Height mm	Width mm	Depth mm
Storage box	220	400	300



Curing Time Injection Adhesive VMU plus

Temperature in drill hole	Cartridge temperature ¹⁾	Max. Gel time	Curing time	
			Dry base material	Wet base material
-10°C – -6°C	+15°C – +40°C	90 min	24 h	48 h
-5°C – -1°C		90 min	14 h	28 h
0°C – +4°C		45 min	7 h	14 h
+5°C – +9°C	+5°C – +40°C	25 min	2 h	4 h
+10°C – +19°C	(+25°C) ²⁾	15 min	80 min	160 min
+20°C – +24°C		6 min	45 min	90 min
+25°C – +29°C		6 min (4 min) ²⁾	45 min (25 min) ²⁾	90 min (50 min) ²⁾
+30°C – +34°C		4 min (2,5 min) ²⁾	25 min (15 min) ²⁾	50 min (30 min) ²⁾
+35°C – +39°C	+5°C – +40°C	2 min (2,5 min) ²⁾	20 min (15 min) ²⁾	40 min (30 min) ²⁾
+40°C	(< +20°C) ²⁾	1,5 min (2,5 min) ²⁾	15 min	30 min

¹⁾When installing

²⁾Values in brackets for rebar connections (ETA-11/0514)

Curing Time Injection Adhesive VMU plus Polar

- Cartridge temperature during installing -20°C to +10°C

Temperature (°C) of the base material	Gel time	Curing time	
		dry base material	wet base material
-20°C to -16°C	75 min	24 h	48 h
-15°C to -11°C	55 min	16 h	32 h
-10°C to -6°C	35 min	10 h	20 h
-5°C to -1°C	20 min	5 h	10 h
0°C to +4°C	10 min	2,5 h	5 h
+5°C to +9°C	6 min	80 min	160 min
+10°C	6 min	60 min	120 min

Threaded Studs for the Injection System VMU plus in concrete:
A flexible system means less inventory

The flexible anchoring depths of the Injection System VMU plus make it possible to adjust the setting depths to the required load. This allows at low loads, the use of shorter anchor rods with correspondingly shorter drilling depths, high loads can be supported by correspondingly deeper anchorage depths.

All anchor rod groups from the existing MKT range listed below can be used with the Injection System VMU plus. But these anchor rods can, according to the applied load, be set deeper or shallower. The minimum and maximum possible anchorage depths are specified in the assessment for each diameter and can be found in the extract from Permissible Service Conditions of ETA-11/0415 on the following pages.

Variable anchorage depth:

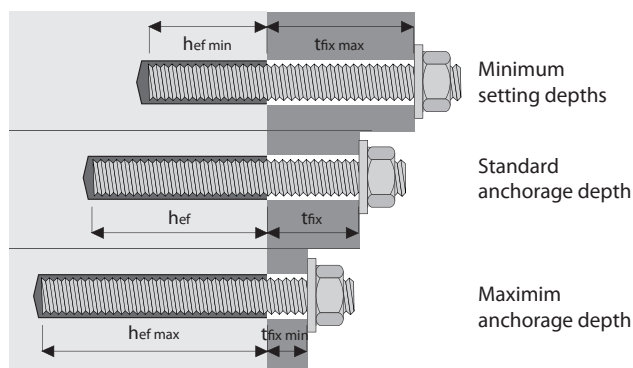

hef + tfix = Usable length of the threaded rod (without nut and washer)

Threaded Studs for applications in cracked and non-cracked concrete

Threaded Stud VMU-A

Steel, zinc plated 5.8



- ➔ May be used in structures subject to dry internal conditions
- ➔ Steel, zinc plated grade 8.8 on demand or as threaded studs VM-A

Threaded Stud VMU-A A4

Stainless steel A4



- ➔ May be used in structures subject to dry internal conditions or to external atmospheric exposure
- ➔ Stainless steel HCR (1.4529) on demand

Description	Ref. No.	Usable length in concrete mm	Pkg. cont. pcs.	Weight per pkg. kg
VMU-A 8x100	31510101	90	10	0,42
VMU-A 8x110	31515101	100	10	0,46
VMU-A 8x130	31525101	120	10	0,52
VMU-A 8x145	31528101	135	10	0,55
VMU-A 8x160	31530101	150	10	0,60
VMU-A 8x205	31550101	195	10	0,74
VMU-A 10x110	31605101	100	10	0,75
VMU-A 10x130	31625101	120	10	0,85
VMU-A 10x150	31630101	140	10	0,95
VMU-A 10x165	31635101	155	10	1,02
VMU-A 10x190	31645101	180	10	1,15
VMU-A 10x260	31655101	250	10	1,50
VMU-A 12x120	31717101	105	10	1,14
VMU-A 12x130	31718101	115	10	1,21
VMU-A 12x135	31710101	120	10	1,25
VMU-A 12x155	31720101	140	10	1,42
VMU-A 12x175	31730101	160	10	1,54
VMU-A 12x185	31734101	170	10	1,63
VMU-A 12x210	31740101	195	10	1,82
VMU-A 12x225	31748101	210	10	1,89
VMU-A 12x250	31750101	235	10	2,13
VMU-A 12x265	31757101	250	10	2,18
VMU-A 12x300	31760101	285	10	2,50
VMU-A 16x160	31810101	140	10	2,65
VMU-A 16x175	31815101	155	10	2,85
VMU-A 16x205	31820101	185	10	3,25
VMU-A 16x235	31830101	215	10	3,65
VMU-A 16x300	31840101	280	10	4,53
VMU-A 20x240	31910101	220	10	5,85
VMU-A 20x260	31915101	240	10	6,30
VMU-A 20x285	31920101	265	10	6,75
VMU-A 20x300	31925101	280	10	7,15
VMU-A 20x350	31930101	330	10	8,10
VMU-A 20x400	31935101	380	10	9,10
VMU-A 24x290	31960101	265	5	4,95
VMU-A 24x350	31965101	325	5	5,85
VMU-A 24x400	31970101	375	5	6,60
VMU-A 30x370	31990101	340	5	9,90

Description	Ref. No.	Usable length in concrete mm	Pkg. cont. pcs.	Weight per pkg. kg
VMU-A 8x100 A4	31510501	90	10	0,42
VMU-A 8x110 A4	31515501	100	10	0,46
VMU-A 8x130 A4	31525501	120	10	0,52
VMU-A 8x145 A4	31528501	135	10	0,55
VMU-A 8x160 A4	31530501	150	10	0,60
VMU-A 8x205 A4	31550501	195	10	0,74
VMU-A 10x110 A4	31605501	100	10	0,75
VMU-A 10x130 A4	31625501	120	10	0,85
VMU-A 10x150 A4	31630501	140	10	0,95
VMU-A 10x165 A4	31635501	155	10	1,02
VMU-A 10x190 A4	31645501	180	10	1,15
VMU-A 10x260 A4	31655501	250	10	1,50
VMU-A 12x120 A4	31717501	105	10	1,14
VMU-A 12x130 A4	31718501	115	10	1,21
VMU-A 12x135 A4	31710501	120	10	1,25
VMU-A 12x155 A4	31720501	140	10	1,42
VMU-A 12x175 A4	31730501	160	10	1,54
VMU-A 12x185 A4	31734501	170	10	1,63
VMU-A 12x210 A4	31740501	195	10	1,82
VMU-A 12x225 A4	31748501	210	10	1,89
VMU-A 12x250 A4	31750501	235	10	2,13
VMU-A 12x265 A4	31757501	250	10	2,18
VMU-A 12x300 A4	31760501	285	10	2,50
VMU-A 16x160 A4	31810501	140	10	2,65
VMU-A 16x175 A4	31815501	155	10	2,85
VMU-A 16x205 A4	31820501	185	10	3,25
VMU-A 16x235 A4	31830501	215	10	3,65
VMU-A 16x300 A4	31840501	280	10	4,53
VMU-A 20x240 A4	31910501	220	10	5,85
VMU-A 20x260 A4	31915501	240	10	6,30
VMU-A 20x285 A4	31920501	265	10	6,75
VMU-A 20x300 A4	31925501	280	10	7,15
VMU-A 24x290 A4	31960501	265	5	4,95
VMU-A 24x350 A4	31965501	325	5	5,85
VMU-A 24x400 A4	31970501	375	5	6,60
VMU-A 30x370 A4	31990501	340	5	9,90

Chemical Anchors

Threaded Studs and Internally Threaded Sleeves for applications in **cracked and non-cracked concrete**
Threaded Stud VM-A

Steel, zinc plated 5.8

 Threaded studs, of 1 meter length, to be cut to the required length

 Comes with manufacturer's certificate (3.1 EN10204) in every package

Description	Ref. No.	Thread	Length	Package content pcs.	Weight per pkg. kg
			mm		
VM-A 8x1000	31199101	M8	1000	10	3,91
VM-A 10x1000	31299101	M10	1000	10	5,5
VM-A 12x1000	31399101	M12	1000	10	7,76
VM-A 16x1000	31599101	M16	1000	10	13,6
VM-A 20x1000	31699101	M20	1000	5	10,8
VM-A 24x1000	31799101	M24	1000	5	15,35

Threaded Stud VM-A

Stainless steel A4



 Threaded studs, of 1 meter length, to be cut to the required length

 Comes with manufacturer's certificate (3.1 EN10204) in every package

Description	Ref. No.	Thread	Length	Package content pcs.	Weight per pkg. kg
			mm		
VM-A 8x1000 A4	31199501	M8	1000	10	3,77
VM-A 10x1000 A4	31299501	M10	1000	10	5,43
VM-A 12x1000 A4	31399501	M12	1000	10	8,03
VM-A 16x1000 A4	31599501	M16	1000	10	13,95
VM-A 20x1000 A4	31699501	M20	1000	5	11,0
VM-A 24x1000 A4	31799501	M24	1000	5	15,6

Threaded Stud VM-A

Steel, zinc plated 8.8

 Threaded studs, of 1 meter length, to be cut to the required length

 Comes with manufacturer's certificate (3.1 EN10204) in every package

Description	Ref. No.	Thread	Length	Package content pcs.	Weight per pkg. kg
			mm		
VM-A 8x1000 8.8	31199181	M8	1000	10	3,91
VM-A 10x1000 8.8	31299181	M10	1000	10	5,5
VM-A 12x1000 8.8	31399181	M12	1000	10	7,76
VM-A 16x1000 8.8	31599181	M16	1000	10	13,6

Threaded Stud V-A

Steel, zinc plated 5.8

Dimensions see page 144



 For use in structures subject to dry internal conditions

 Steel, zinc plated 8.8 on demand

Threaded Stud V-A A4

Stainless steel A4

Dimensions see page 144

 For use in structures subject to dry internal conditions or external atmospheric exposure

Threaded Stud V-A fvz

Steel, hot dip galvanized 5.8

Dimensions see page 144



 For use in structures subject to dry internal conditions

 Steel hot dip galvanized 8.8 on demand

Threaded Stud V-A HCR

Stainless steel HCR

Dimensions see page 144



 For use in particularly corrosive environments

 High corrosion resistant steel 1.4529 (HCR)

Internally Threaded Sleeve VMU-IG

Steel, zinc plated 5.8/Stainless steel A4

 With internal thread

 For cracked and non-cracked concrete

Description	Ref. No.		Drill hole-Ø x depth mm	Outer-Ø x Length mm	Thread depth min / max mm	Package content pcs.	Weight per pkg. kg
	Steel, zinc plated	Stainless steel A4					
VMU-IG M6x80	31502101	31502501	12 x 80	10 x 80	8 / 20	10	0,38
VMU-IG M6x90	31503101	31503501	12 x 90	10 x 90	8 / 20	10	0,42
VMU-IG M8x80	31562101	31562501	14 x 80	12 x 80	8 / 20	10	0,52
VMU-IG M8x100	31563101	31563501	14 x 100	12 x 100	8 / 20	10	0,66
VMU-IG M10x80	31601101	31601501	18 x 80	16 x 80	10 / 25	10	0,92
VMU-IG M10x100	31602101	31602501	18 x 100	16 x 100	10 / 25	10	1,18

Other dimensions on demand.

Threaded Studs, Internally Threaded Sleeves and Perfo Sleeves for applications in solid and hollow base material

Threaded Stud VMU-A

Steel, zinc plated 5.8/Stainless steel A4



→ Steel hot dip galvanized and stainless steel HCR (1.4529) on demand



Description	Ref. No.		Usable length mm	Solid base material without SH			Solid and hollow base material with VM-SH						Package content Pcs.	Weight per pkg. kg
	Steel, zinc plated	Stainless steel A4		Drill hole-Ø x depth mm	Maximum Fixture thickness fix mm	Drill hole Ø x depth mm								
						VM-SH 12x85	VM-SH 16x90	VM-SH 16x135	VM-SH 20x90	VM-SH 20x135	VM-SH 20x205			
						12x85	16x90	16x135	20x90	20x135	20x205			
							Maximum Fixture thickness t _{fix} mm							
VMU-A 8 x 100	31510101	31510501	90	10 x 80	10	10	5	-	-	-	-	10	0,42	
VMU-A 8 x 110	31515101	31515501	100	10 x 80	20	20	15	-	-	-	-	10	0,46	
VMU-A 8 x 130	31525101	31525501	120	10 x 80	40	40	35	-	-	-	-	10	0,52	
VMU-A 8 x 145	31528101	31528501	135	10 x 80	55	55	50	5	-	-	-	10	0,55	
VMU-A 8 x 160	31530101	31530501	150	10 x 80	70	70	65	20	-	-	-	10	0,60	
VMU-A 8 x 205	31550101	31550501	195	10 x 80	115	115	110	65	-	-	-	10	0,74	
VMU-A 10 x 110	31605101	31605501	100	12 x 90	10	-	15	-	-	-	-	10	0,75	
VMU-A 10 x 130	31625101	31625501	120	12 x 90	30	-	35	-	-	-	-	10	0,85	
VMU-A 10 x 150	31630101	31630501	140	12 x 90	50	-	55	10	-	-	-	10	0,95	
VMU-A 10 x 165	31635101	31635501	155	12 x 90	65	-	70	25	-	-	-	10	1,02	
VMU-A 10 x 190	31645101	31645501	180	12 x 90	90	-	95	50	-	-	-	10	1,15	
VMU-A 10 x 260	31655101	31655501	250	12 x 90	160	-	165	120	-	-	-	10	1,50	
VMU-A 12 x 120	31717101	31717501	105	14 x 100	5	-	-	-	20	-	-	10	1,14	
VMU-A 12 x 130	31718101	31718501	115	14 x 100	15	-	-	-	30	-	-	10	1,21	
VMU-A 12 x 135	31710101	31710501	120	14 x 100	20	-	-	-	35	-	-	10	1,25	
VMU-A 12 x 155	31720101	31720501	140	14 x 100	40	-	-	-	55	10	-	10	1,42	
VMU-A 12 x 175	31730101	31730501	160	14 x 100	60	-	-	-	75	30	-	10	1,54	
VMU-A 12 x 185	31734101	31734501	170	14 x 100	70	-	-	-	85	40	-	10	1,63	
VMU-A 12 x 210	31740101	31740501	195	14 x 100	95	-	-	-	110	65	-	10	1,82	
VMU-A 12 x 225	31748101	31748501	210	14 x 100	110	-	-	-	125	80	10	10	1,89	
VMU-A 12 x 250	31750101	31750501	235	14 x 100	135	-	-	-	150	105	35	10	2,13	
VMU-A 12 x 265	31757101	31757501	250	14 x 100	150	-	-	-	165	120	50	10	2,18	
VMU-A 12 x 300	31760101	31760501	285	14 x 100	185	-	-	-	200	155	85	10	2,50	
VMU-A 16 x 160	31810101	31810501	140	18 x 100	40	-	-	-	55	10	-	10	2,65	
VMU-A 16 x 175	31815101	31815501	155	18 x 100	55	-	-	-	70	25	-	10	2,85	
VMU-A 16 x 205	31820101	31820501	185	18 x 100	85	-	-	-	100	55	-	10	3,25	
VMU-A 16 x 235	31830101	31830501	215	18 x 100	115	-	-	-	130	85	15	10	3,65	
VMU-A 16 x 300	31840101	31840501	280	18 x 100	180	-	-	-	195	150	80	10	4,53	

Internally Threaded Sleeve VMU-IG

Steel, zinc plated 5.8/Stainless steel A4



→ With internal thread

→ Approved for solid and hollow base material



Description	Ref. No.		Solid base material without SH Drill hole Ø x depth mm	Solid and hollow base material with SH		Outer-Ø x Length mm	Thread depth min / max mm	Package content pcs.	Weight per pkg. kg
	Steel, zinc plated	Stainless steel A4		VM-SH 16x85	VM-SH 20x85				
				Drill hole-Ø x depth mm	Drill hole-Ø x depth mm				
VMU-IG M6x80	31502101	31502501	-	16 x 90	-	10 x 80	8 / 20	10	0,38
VMU-IG M6x90	31503101	31503501	12 x 90	-	-	10 x 90	8 / 20	10	0,42
VMU-IG M8x80	31562101	31562501	-	-	20 x 90	12 x 80	8 / 20	10	0,52
VMU-IG M8x100	31563101	31563501	14 x 100	-	-	12 x 100	8 / 20	10	0,60
VMU-IG M10x80	31601101	31601501	-	-	20 x 90	16 x 80	10 / 25	10	0,92
VMU-IG M10x100	31602101	31602501	18 x 100	-	-	16 x 100	10 / 25	10	1,18

Perfo Sleeve VM-SH

Polypropylen

→ Approved for hollow base material



Description	Ref. No.	Drill hole Ø x depth mm	For threaded studs	For internally threaded sleeves	Appropriate for cleaning brush	Package content Pcs.	Weight per pkg. kg
VM-SH 12 x 80	28151201	12 x 85	M8	-	RB 12 M6	10	0,02
VM-SH 16 x 85	28152001	16 x 90	M8 / M10	VMU-IG M6 x 80	RB 16 M6	10	0,03
VM-SH 16 x 130	28153001	16 x 135	M8 / M10	-	RB 16 M6	10	0,04
VM-SH 20 x 85	28154001	20 x 90	M12 / M16	VMU-IG M8 x 80/VMU-IG M10 x 80	RB 20 M6	10	0,04
VM-SH 20 x 130	28154301	20 x 135	M12 / M16	-	RB 20 M6	10	0,07
VM-SH 20 x 200	28154601	20 x 205	M12 / M16	-	RB 20 M6	10	0,10

Accessories

Possible combinations static mixer / Extension tube / Retaining Washer:



Extension tubes



- Extension tubes for deeper drill holes
- Two diameters available

Description	Ref. No.	Length mm	Ø mm	To use in conjunction with	Pkg. cont. pcs.	Weight per pkg. kg
VM-XE 10/200	28306011	200	10	VM-XL, VM-X	12	0,12
VM-XE 10/500	85951101	500	10	VM-XL, VM-X	10	0,20
VM-XE 10/1000	85952101	1000	10	VM-XL, VM-X	10	0,30
VM-XLE 16/250	85959101	250	16	VM-XL	10	0,30
VM-XLE 16/1000	85956101	1000	16	VM-XL	10	1,15

Retaining Washer VM-IA



- For bubble-free filling of the drill hole
- Suitable for extension tubes VM-XE 10 and VM-XLE 16

Description	Ref. No.	Suitable for drill hole Ø mm	Color	Suitable for		Pkg. cont. pcs.	Weight per pkg. kg
				Threaded stud	Rebar		
VM-IA 14	85914201	14	black	M12	Ø10	20	0,02
VM-IA 16	85916201	16	black	-	Ø12	20	0,02
VM-IA 18	85918201	18	black	M16	Ø14	20	0,02
VM-IA 20	85920201	20	black	-	Ø16	20	0,06
VM-IA 24	85924101	24	black	M20	Ø20	20	0,06
VM-IA 25	85925201	25	black	-	Ø20	20	0,06
VM-IA 28	85928101	28	black	M24	Ø22	20	0,08
VM-IA 32	85932201	32	black	M27	Ø24, 25	20	0,08
VM-IA 35	85935201	35	black	M30	Ø28	20	0,08
VM-IA 40	85938201	40	black	-	Ø32	20	0,08

Cleaning brush RB M6



- With connection thread M6
- Extensions for large depths
- For drilling machines with keyed chuck or with SDS plus adaptor for SDS plus drill holder
- Direct clamping into the drilling machine with toothed drill chuck is possible

Description	Ref. No.	Suitable for drill hole Ø mm	Total length of brush mm	Suitable for		Pkg. cont. pcs.	Weight per piece kg
				Threaded stud	Internally threaded sleeve		
RB 10 M6	33510101	10	130	M8	-	1	0,05
RB 12 M6	33512101	12	140	M10	Ø8	1	0,05
RB 14 M6	33514101	14	180	M12	Ø10	1	0,05
RB 16 M6	33516101	16	200	-	Ø12	1	0,05
RB 18 M6	33518101	18	200	M16	Ø14	1	0,05
RB 20 M6	33520101	20	220	-	Ø16	1	0,05
RB 24 M6	33524101	24	250	M20	Ø20	1	0,06
RB 26 M6	33526101	25,26	290	-	Ø20	1	0,06
RB 28 M6	33528101	28	260	M24	Ø22	1	0,06
RB 32 M6	33532101	32	350	M27	Ø24,25	1	0,08
RB 35 M6	33535101	35	350	M30	Ø28	1	0,08
RB 40 M6	33537101	40	350	-	Ø32	1	0,08
RBL M6	33968101		Brush extension 150 mm with connection thread M6			1	0,09
RBL M6 SDS	33350101		SDS Plus adaptor with internal thread (M6)			1	0,06

Blow-out pump VM-AP



- For approval-compliant air-cleaning of drill holes in masonry as well as non-cracked concrete with a diameter up to 20 mm and a maximum drill hole depth ten times larger than the diameter of the threaded stud (VMU plus)
- For best drill hole cleaning, the hose must reach the bottom of the drill hole

Description	Ref. No.	Hose Ø mm	For drill hole Ø mm	Max. drill hole depth ¹⁾ mm	Pkg. cont. pcs	Weight per piece kg
Blow-out pump VM-AP 360	33200101	8	8 ¹⁾ -20	330	1	0,27

¹⁾With extension tube Ø 6 x 100mm
²⁾For through fastening: Maximum drill hole depth through fixture

Air gun VM-ABP



→ For approval-compliant drill hole cleaning with compressed air for drill holes with a diameter larger than 6 mm

→ For best drill hole cleaning, the nozzle of the air gun must reach the bottom of the drill hole

NEW

Description	Ref. No.	Nozzle- ø mm	For drill hole Ø mm	Max. drill hole depth ¹⁾ mm	Pkg. cont. pcs.	Weight per piece kg
VM-ABP 200	33090101	5	6-20	240	1	0,55
VM-ABP 250	33100101	16	18-40	240	1	1,00
VM-ABP 500	33106101	16	18-40	480	1	1,30

¹⁾For through fastening: Maximum drill hole depth through fixture

Air gun VM-ABP



→ Drill hole cleaning with compressed air for holes up to one meter

→ For best drill hole cleaning the nozzle of the air-gun must reach to the bottom of the drill hole

Description	Ref. No.	Nozzle Ø mm	Max. Drill hole depth mm	For drill hole Ø mm	Pkg. cont. pcs	Weight per piece kg
VM-ABP 1000	85806101	14	1000	16-40	1	0,32

Dispenser VM-P Profi



→ Professional dispenser with an ideal center of gravity for more comfortable working

→ Automatic pressure release for minimum adhesive overrun

Description	Ref. No.	Suitable for cartridge	Pkg. cont. pcs	Weight per piece kg
VM-P 345 Profi	28350511	150ml, 280ml, 300ml, 345ml also suitable for silicone cartridges	1	1,00
VM-P 380 Profi	28351001	380ml, 410ml, 420ml	1	1,10

Dispenser VM-P Standard



→ For occasional use, metal version

→ Piston rod with adjusting screw

Description	Ref. No.	Suitable for cartridge	Pkg. cont. pcs	Weight per piece kg
VM-P 345 Standard	28350505	150ml, 280ml, 300ml, 345ml also suitable for silicone cartridges	1	1,00
VM-P 380 Standard	28353005	380ml, 410ml, 420ml	1	1,15

Dispenser VM-P Pneumatic



→ Professional air tool with an optimum center of gravity and quick cartridge exchange

→ Automatic pressure release system reduces adhesive overrun to a minimum

→ Single-hand pressure regulation to adjust the piston speed

→ With compressed air connection nipple

Description	Ref. No.	Suitable for cartridge	max. working pressure	Pkg. cont. pcs	Weight per piece kg
VM-P 345 Pneumatic	28350601	280ml, 300ml, 345ml	8 bar, 40l/min	1	2,41
VM-P 380 Pneumatic	28352002	380ml, 410ml, 420ml	8 bar, 40l/min	1	2,00
VM-P 825 Pneumatic	28352110	825ml	8 bar, 40l/min	1	5,00

Dispenser VM-P Akku



¹⁾ with Akku 18V/2,0 Ah

→ Professional, solid battery cartridge dispenser in a plastic case

→ Repeat function, for retrieving the last fill quantity

→ Stepless variable pressing speed

→ Overrun-quantity-stop by automatic return after release of the dispensing switch

Description	Ref. No.	Suitable for cartridge	Press-out force kN	Weight ¹⁾ kg	Dimensions ¹⁾ L x B x H mm	Pkg. cont. pcs	Weight per piece kg
VM-P 345 Akku	28350801	345ml	5,0	3,53	395 x 180 x 285	1	7,72
VM-P 380 Akku	28352601	380ml, 410ml, 420ml	3,95	3,62	375 x 180 x 285	1	7,80
VM-P 585 Akku	28353301	385ml, 585ml	5,0	3,86	440 x 180 x 285	1	8,05
Accessories (for all models)							
Replacement battery	28352411		18 V/2,0 Ah			1	1,00
Shoulder strap	28359991		adjustable			1	0,02

System case and accessories for post-installed rebar connections to use with injection system VMU plus (fast curing time) or the injection system VME (long curing times, optimized for very large and deep drill holes)

Description and content:

Compact system case including equipment for every rebar diameter as well as all the tools necessary for the installation of post-installed rebar connections using the Injection System VME or VMU plus. All parts also sold separately.



Drilling:

- Drilling aid device
- Flat- / Ring wrench

Accessories for drill hole cleaning:

- 1 of each air hose RS 25 and RS 35
- 1 of each blow-out nozzle RD 12/14, 16/18, 20/25, 30/35
- 1 of each cleaning brush RB 12 M8 – RB 35 M8
- Connection set RS with air valve and connector
- 5 Brush extensions RBL M8, L = 500 mm
- 1 SDS-plus adapter RBL M8-SDS

Accessories for injection:

- 5 Static mixer VM-XL
- 5 of each retaining washer VM-IA Ø12 mm - Ø35 mm
- 5 of each extension tube VM-XE 10/500 and VM-XLE 16/500
- Frame saw

Other:

- Approval
- Installation sheet and Installation report (available for download at www.mkt.de)
- Filling quantity tables
- Adhesive tape
- Measuring tape
- Thermometer
- Ear protection, Breathing protection, Protective goggles and protective gloves

Description	Ref. No.	Suitable for drill hole-Ø mm	Pkg. content pcs.	Weight per piece kg
VME System case	85999101	12 - 35	1	11,8

System Components

- Filling of drill hole
- For drill hole diameter 12 - 35 mm

Description	Ref. No.	Length mm	Rebar-Ø mm	Suitable for drill hole Ø mm	Colour	Package content pcs.	Weight per pkg. kg
Extension pipe							
VM-XE 10/1000	85952101	1000	8 - 12	12 - 16	white	10	0,30
VM-XE 10/2000	85954101	2000	8 - 12	12 - 16	white	10	0,65
VM-XLE 16/1000	85956101	1000	14 - 28	18 - 35	grey	10	1,15
VM-XLE 16/2000	85958101	2000	14 - 28	18 - 35	grey	10	3,50
Retaining washer (only for post-installed rebar connections. Fits to the system case)							
VM-IA 12	85912101	-	8	12	white	20	0,04
VM-IA 14	85914101	-	10	14	yellow	20	0,01
VM-IA 16	85916101	-	12	16	blue	20	0,02
VM-IA 18	85918101	-	14	18	black	20	0,01
VM-IA 20	85920101	-	16	20	grey	20	0,02
VM-IA 25	85925101	-	20	25	green	20	0,05
VM-IA 32	85932101	-	25	32	brown	20	0,10
VM-IA 35	85935101	-	28	35	red	20	0,12

Extension pipe VM-XE and VM-XLE can be cut to corresponding drill hole depth.
Extension pipe > 2000 mm on demand.

Reinforced brushes RB M8

- Reinforced brushes with connecting thread M8 for deeper drill holes

Description	Ref. No.	Rebar-Ø mm	Suitable for drill hole Ø mm	Pkg. content pcs.	Weight per piece kg
RB 12 M8	85812101	8	12	1	0,05
RB 14 M8	85814101	10	14	1	0,05
RB 16 M8	85816101	12	16	1	0,05
RB 18 M8	85818101	14	18	1	0,05
RB 20 M8	85820101	16	20	1	0,05
RB 25 M8	85825101	20	25	1	0,06
RB 32 M8	85832101	25	32	1	0,08
RB 35 M8	85835101	28	35	1	0,08
Brush extension RBL M8, L= 500 mm	85871101	8 - 28	12 - 35	1	0,32
SDS-Plus adapter RBL M8 SDS	85881101	-	12 - 35	1	0,07

Please select Brush extension RBL and SDS-Plus adapter according to depth of drill hole.
For drill hole depth > 500 mm, the proper number of Brush extensions must be connected.

Blow-out nozzle



- Every nozzle covers two drill hole diameters
- Fits on the air hose RS

Description	Ref. No.	Rebar-Ø mm	Suitable for drill hole-Ø mm	Pkg. content pcs.	Weight per piece kg
Blow-out nozzle RD 12/14	85852101	8 - 10	12 - 14	1	0,01
Blow-out nozzle RD 16/18	85854101	12 - 14	16 - 18	1	0,02
Blow-out nozzle RD 20/25	85856101	16 - 20	20 - 25	1	0,03
Blow-out nozzle RD 30/35	85858101	24 - 28	30 - 35	1	0,05

Air hose



- pre-assembled set with connectors
- To use with air valve and blow-out nozzle

Description	Ref. No.	Rebar-Ø mm	Suitable for drill hole-Ø mm	Pkg. content pcs.	Weight per piece kg
Air hose RS 25 (2 m)	85802101	8 - 20	12 - 25	1	0,10
Air hose RS 35 (3 m)	85804101	24 - 28	30 - 35	1	0,40

Air Valve



- For drill hole cleaning with compressed air

Description	Ref. No.	Rebar-Ø mm	Suitable for drill hole-Ø mm	Pkg. content pcs.	Weight per piece kg
Connection Set RS with valve and connector	85890101	8 - 28	12 - 35	1	0,40



Extract from Permissible Service Conditions of European Technical Assessment ETA-11/0415

Approved loads without influence of spacing and edge distance in dry or wet concrete for temperature range I -40°C to +24°C/+40°C¹⁾ and for temperature range II -40°C to +50°C/+80°C¹⁾ (For temperature range III -40°C to +72°C/+120°C¹⁾ see ETA-11/0415).

Total safety factor as per ETAG 001 included (γ_M and γ_p). Load capacities under fire exposure see page 168.

Loads and performance data

Injection System VMU plus, threaded stud steel 5.8				M8	M10	M12	M16	M20	M24	M27	M30	
Range of anchorage depths	$h_{ef,min} - h_{ef,max}$	[mm]		60 - 160	60 - 200	70 - 240	80 - 320	90 - 400	96 - 480	108 - 540	120 - 600	
Approved loads, tension for $h_{ef,min} - h_{ef,max}$												
cracked concrete												
Range of temperature	24°C/40°C ¹⁾	C20/25	appr. N	[kN]	2,9-7,7	3,7-12,5	5,8-19,7	8,8-35,1	12,2-54,9	13,4-79,0	16,0-109,5	18,8-133,3
	50°C/80°C ¹⁾	C20/25	appr. N	[kN]	1,8-4,8	2,6-8,7	4,2-14,4	6,4-25,5	9,0-39,9	11,5-57,4	16,0-81,8	18,8-101,0
Approved loads, tension for $h_{ef,min} - h_{ef,max}$												
non-cracked concrete												
Range of temperature	24°C/40°C ¹⁾	C20/25	appr. N	[kN]	7,2-8,6	9,0-13,8	11,7-20,0	14,3-37,1	17,1-58,1	18,8-83,8	22,5-109,5	26,3-133,3
	50°C/80°C ¹⁾	C20/25	appr. N	[kN]	5,4-8,6	6,7-13,8	9,4-20,0	14,3-37,1	17,1-58,1	18,8-83,8	22,5-109,5	26,3-133,3
Approved loads, shear for $h_{ef,min} - h_{ef,max}$												
cracked concrete												
Range of temperature	24°C/40°C ¹⁾	C20/25	appr. V	[kN]	5,1	8,6	12,0	21,1-22,3	29,3-34,9	32,2-50,3	38,5-65,7	45,1-80,0
	50°C/80°C ¹⁾	C20/25	appr. V	[kN]	3,6-5,1	6,3-8,6	10,1-12,0	15,3-22,3	21,5-34,9	27,6-50,3	38,5-65,7	45,1-80,0
Approved loads, shear for $h_{ef,min} - h_{ef,max}$												
non-cracked concrete												
Range of temperature	24°C/40°C ¹⁾	C20/25	appr. V	[kN]	5,1	8,6	12,0	22,3	34,9	45,2-50,3	54,0-65,7	63,2-80,0
	50°C/80°C ¹⁾	C20/25	appr. V	[kN]	5,1	8,6	12,0	22,3	34,9	45,2-50,3	54,0-65,7	63,2-80,0

Injection System VMU plus, threaded stud steel 8.8				M8	M10	M12	M16	M20	M24	M27	M30	
Range of anchorage depths	$h_{ef,min} - h_{ef,max}$	[mm]		60 - 160	60 - 200	70 - 240	80 - 320	90 - 400	96 - 480	108 - 540	120 - 600	
Approved loads, tension for $h_{ef,min} - h_{ef,max}$												
cracked concrete												
Range of temperature	24°C/40°C ¹⁾	C20/25	appr. N	[kN]	2,9-7,7	3,7-12,5	5,8-19,7	8,8-35,1	12,2-54,9	13,4-79,0	16,0-118,1	18,8-145,9
	50°C/80°C ¹⁾	C20/25	appr. N	[kN]	1,8-4,8	2,6-8,7	4,2-14,4	6,4-25,5	9,0-39,9	11,5-57,4	16,0-81,8	18,8-101,0
Approved loads, tension for $h_{ef,min} - h_{ef,max}$												
non-cracked concrete												
Range of temperature	24°C/40°C ¹⁾	C20/25	appr. N	[kN]	7,2-13,8	9,0-21,9	11,7-31,9	14,3-59,5	17,1-93,3	18,8-134,3	22,5-175,2	26,3-202,0
	50°C/80°C ¹⁾	C20/25	appr. N	[kN]	5,4-13,8	6,7-21,9	9,4-31,9	14,3-57,4	17,1-89,8	18,8-122,1	22,5-136,3	26,3-145,9
Approved loads, shear for $h_{ef,min} - h_{ef,max}$												
cracked concrete												
Range of temperature	24°C/40°C ¹⁾	C20/25	appr. V	[kN]	5,7-8,6	9,0-13,1	13,8-19,4	21,1-36,0	29,3-56,0	32,2-80,6	38,5-105,1	45,1-128,0
	50°C/80°C ¹⁾	C20/25	appr. V	[kN]	3,6-8,6	6,3-13,1	10,1-19,4	15,3-36,0	21,5-56,0	27,6-80,6	38,5-105,1	45,1-128,0
Approved loads, shear for $h_{ef,min} - h_{ef,max}$												
non-cracked concrete												
Range of temperature	24°C/40°C ¹⁾	C20/25	appr. V	[kN]	8,6	13,1	19,4	34,4-36,0	41,1-56,0	45,2-80,6	54,0-105,1	63,2-128,0
	50°C/80°C ¹⁾	C20/25	appr. V	[kN]	8,6	13,1	19,4	34,4-36,0	41,1-56,0	45,2-80,6	54,0-105,1	63,2-128,0

Injection System VMU plus, threaded stud stainless steel A4, HCR				M8	M10	M12	M16	M20	M24	M27	M30	
Range of anchorage depths	$h_{ef,min} - h_{ef,max}$	[mm]		60 - 160	60 - 200	70 - 240	80 - 320	90 - 400	96 - 480	108 - 540	120 - 600	
Approved loads, tension for $h_{ef,min} - h_{ef,max}$												
cracked concrete												
Range of temperature	24°C/40°C ¹⁾	C20/25	appr. N	[kN]	2,9-7,7	3,7-12,5	5,8-19,7	8,8-35,1	12,2-54,9	13,4-79,0	16,0-57,4	18,8-70,2
	50°C/80°C ¹⁾	C20/25	appr. N	[kN]	1,8-4,8	2,6-8,7	4,2-14,4	6,4-25,5	9,0-39,9	11,5-57,4	16,0-57,4	18,8-70,2
Approved loads, tension for $h_{ef,min} - h_{ef,max}$												
non-cracked concrete												
Range of temperature	24°C/40°C ¹⁾	C20/25	appr. N	[kN]	7,2-9,9	9,0-15,7	11,7-22,5	14,3-42,0	17,1-65,3	18,8-94,3	22,5-57,4	26,3-70,2
	50°C/80°C ¹⁾	C20/25	appr. N	[kN]	5,4-9,9	6,7-15,7	9,4-22,5	14,3-42,0	17,1-65,3	18,8-94,3	22,5-57,4	26,3-70,2
Approved loads, shear for $h_{ef,min} - h_{ef,max}$												
cracked concrete												
Range of temperature	24°C/40°C ¹⁾	C20/25	appr. V	[kN]	5,7-6,0	9,0-9,2	13,7	21,1-25,2	29,3-39,4	32,2-56,8	34,5	42,0
	50°C/80°C ¹⁾	C20/25	appr. V	[kN]	3,6-6,0	6,3-9,2	10,1-13,7	15,3-25,2	21,5-39,4	27,6-56,8	34,5	42,0
Approved loads, shear for $h_{ef,min} - h_{ef,max}$												
non-cracked concrete												
Range of temperature	24°C/40°C ¹⁾	C20/25	appr. V	[kN]	6,0	9,2	13,7	25,2	39,4	45,2-56,8	34,5	42,0
	50°C/80°C ¹⁾	C20/25	appr. V	[kN]	6,0	9,2	13,7	25,2	39,4	45,2-56,8	34,5	42,0

Spacing and edge distance

Min. thickness of concrete slab for $h_{ef,min} - h_{ef,max}$	h_{min}	[mm]	100-190	100-230	100-270	116-356	138-448	152-536	172-604	190-670
Minimum spacing	s_{min}	[mm]	40	50	60	80	100	120	135	150
Minimum edge distance	c_{min}	[mm]	40	50	60	80	100	120	135	150

Installation parameters

Drill hole diameter	d_o	[mm]	10	12	14	18	24	28	32	35
Clearance hole in the fixture	d_f	[mm]	9	12	14	18	22	26	30	33
Range of drill hole depth for $h_{ef,min} - h_{ef,max}$	h_o	[mm]	60 - 160	60 - 200	70 - 240	80 - 320	90 - 400	96 - 480	108 - 540	120 - 600
Installation torque	$\leq T_{inst}$	[Nm]	10	20	40	80	120	160	180	200

¹⁾ Max. long term temperature / max. short term temperature

Higher concrete strength may lead to higher approved loads. Technical data for water-filled drill holes see approval.

For anchor designing, an easy to operate Software is available on request or can be downloaded at www.mkt.de

Extract from Permissible Service Conditions of European Technical Assessment ETA-11/0415

 Approved loads without influence of spacing and edge distance in dry or wet concrete for temperature range I -40°C to +24°C/+40°C¹⁾ and for temperature range II -40°C to +50°C/+80°C¹⁾ (For temperature range III -40°C to +72°C/+120°C¹⁾ see ETA-11/0415).

 Total safety factor as per ETAG 001 included (γ_M and γ_F).

Loads and performance data

Internally threaded sleeve				IG M6 x 80	IG M6 x 90	IG M8 x 80	IG M8 x 100	IG M10 x 80	IG M10 x 100	IG M12 x 125	IG M16 x 170	IG M20 x 200
Anchorage depth h_{ef}		[mm]		80	90	80	100	80	100	125	170	200

Injection System VMU plus, Internally threaded steel VMU-IG, Steel 5.8

Approved loads, tension for h_{ef}				cracked concrete								
Temperature range	24°C/40°C ¹⁾	C20/25	appr. N [kN]	4,8	4,8	6,6	8,2	8,8	11,0	17,1	28,0	40,4
	50°C/80°C ¹⁾	C20/25	appr. N [kN]	3,5	3,9	4,8	6,0	6,4	8,0	12,5	20,3	33,7
Approved loads, tension for h_{ef}				non-cracked concrete								
Temperature range	24°C/40°C ¹⁾	C20/25	appr. N [kN]	4,8	4,8	8,6	8,6	13,8	13,8	20,0	37,6	56,7
	50°C/80°C ¹⁾	C20/25	appr. N [kN]	4,8	4,8	8,6	8,6	13,8	13,8	20,0	37,6	48,6
Approved loads, shear for h_{ef}				cracked concrete								
Temperature range	24°C/40°C ¹⁾	C20/25	appr. V [kN]	2,9	2,9	5,1	5,1	8,6	8,6	12,0	22,3	34,9
	50°C/80°C ¹⁾	C20/25	appr. V [kN]	2,9	2,9	5,1	5,1	8,6	8,6	12,0	22,3	34,9
Approved loads, shear for h_{ef}				non-cracked concrete								
Temperature range	24°C/40°C ¹⁾	C20/25	appr. V [kN]	2,9	2,9	5,1	5,1	8,6	8,6	12,0	22,3	34,9
	50°C/80°C ¹⁾	C20/25	appr. V [kN]	2,9	2,9	5,1	5,1	8,6	8,6	12,0	22,3	34,9

Injection System VMU plus, Internally threaded VMU-IG, Stainless steel A4, HCR

Approved loads, tension for h_{ef}				cracked concrete								
Temperature range	24°C/40°C ¹⁾	C20/25	appr. N [kN]	5,0	5,3	6,6	8,2	8,8	11,0	17,1	28,0	31,0
	50°C/80°C ¹⁾	C20/25	appr. N [kN]	3,5	3,9	4,8	6,0	6,4	8,0	12,5	20,3	31,0
Approved loads, tension for h_{ef}				non-cracked concrete								
Temperature range	24°C/40°C ¹⁾	C20/25	appr. N [kN]	5,3	5,3	9,9	9,9	14,3	15,7	22,5	42,0	31,0
	50°C/80°C ¹⁾	C20/25	appr. N [kN]	5,3	5,3	9,9	9,9	14,3	15,7	22,5	42,0	31,0
Approved loads, shear for h_{ef}				cracked concrete								
Temperature range	24°C/40°C ¹⁾	C20/25	appr. V [kN]	3,2	3,2	6,0	6,0	9,2	9,2	13,7	25,2	18,6
	50°C/80°C ¹⁾	C20/25	appr. V [kN]	3,2	3,2	6,0	6,0	9,2	9,2	13,7	25,2	18,6
Approved loads, shear for h_{ef}				non-cracked concrete								
Temperature range	24°C/40°C ¹⁾	C20/25	appr. V [kN]	3,2	3,2	6,0	6,0	9,2	9,2	13,7	25,2	18,6
	50°C/80°C ¹⁾	C20/25	appr. V [kN]	3,2	3,2	6,0	6,0	9,2	9,2	13,7	25,2	18,6

Spacing and edge distance

Minimum thickness of concrete slab for h_{ef}	h_{min}	[mm]	110	120	110	130	116	136	169	226	270
Minimum spacing	s_{min}	[mm]	50	50	60	60	80	80	100	120	150
Minimum edge distance	c_{min}	[mm]	50	50	60	60	80	80	100	120	150

Installation parameters

Drill hole diameter	d_o	[mm]	12	12	14	14	18	18	24	28	35
Clearance hole in the fixture	$d_{r\leq}$	[mm]	7	7	9	9	12	12	14	18	22
Range of drill hole depth for h_{ef}	d_o	[mm]	80	90	80	100	80	100	125	170	200
Installation	$T_{inst\leq}$	[Nm]	10	10	10	10	20	20	40	60	100
Amount of adhesive per drill hole		[ml]	6,6	7,4	7,9	9,9	10,9	13,6	22,4	54,9	97,4

¹⁾Max. long term temperature / max. short term temperature

Higher concrete strength may lead to higher approved loads. Technical data for water-filled drill holes see approval.

 For anchor designing, an easy to operate Software is available on request or can be downloaded at www.mkt.de.



Extract from Permissible Service Conditions of European Technical Assessment ETA-11/0415

Approved loads without influence of spacing and edge distance in dry or wet concrete for temperature range I -40°C to +24°C/+40°C¹⁾ and for temperature range II -40°C to +50°C/+80°C¹⁾ (For temperature range III -40°C to +72°C/+120°C¹⁾ see ETA-11/0415). Total safety factor as per ETAG 001 included (γ_M and γ_P).

Injection System VMU plus, reinforcement bars B500B				$\phi 8$	$\phi 10$	$\phi 12$	$\phi 14$	$\phi 16$	$\phi 20$	$\phi 25$	$\phi 28$	$\phi 32$	
Range of anchorage depths	$h_{ef,min} - h_{ef,max}$	[mm]		60-160	60-200	70-240	75-280	80-320	90-400	100-500	112-560	128-640	
Approved loads, tension for $h_{ef,min} - h_{ef,max}$				cracked concrete									
Range of temperature	24°C/40°C ¹⁾	C20/25	appr. N	[kN]	2,9-7,7	3,7-12,5	5,8-19,7	7,2-26,9	8,8-35,1	12,2-54,9	14,3-85,7	16,9-127,1	20,7-166,0
	50°C/80°C ¹⁾	C20/25	appr. N	[kN]	1,8-4,8	2,6-8,7	4,2-14,4	5,2-19,5	6,4-25,5	9,0-39,9	12,5-63,3	16,9-88,0	20,7-114,9
Approved loads, tension for $h_{ef,min} - h_{ef,max}$					non-cracked concrete								
Range of temperature	24°C/40°C ¹⁾	C20/25	appr. N	[kN]	7,2-13,8	9,0-21,6	11,7-31,2	13,0-42,4	14,3-55,4	17,1-86,6	20,0-135,2	23,8-169,6	29,0-217,0
	50°C/80°C ¹⁾	C20/25	appr. N	[kN]	5,4-13,8	6,7-21,6	9,4-31,2	11,8-42,4	14,3-55,4	17,1-86,6	20,0-124,7	23,8-136,8	29,0-153,2
Approved loads, shear for $h_{ef,min} - h_{ef,max}$					cracked concrete								
Range of temperature	24°C/40°C ¹⁾	C20/25	appr. V	[kN]	5,7-6,5	9,0-10,1	13,8-14,5	17,3-19,8	21,1-25,9	29,3-40,4	34,3-63,1	40,6-79,2	49,7-103,4
	50°C/80°C ¹⁾	C20/25	appr. V	[kN]	3,6-6,5	6,3-10,1	10,1-14,5	12,6-19,8	15,3-25,9	21,5-40,4	29,9-63,1	40,6-79,2	49,7-103,4
Approved loads, shear for $h_{ef,min} - h_{ef,max}$					non-cracked concrete								
Range of temperature	24°C/40°C ¹⁾	C20/25	appr. V	[kN]	6,5	10,1	14,5	19,8	25,9	40,4	48,1-63,1	57,0-79,2	69,6-103,4
	50°C/80°C ¹⁾	C20/25	appr. V	[kN]	6,5	10,1	14,5	19,8	25,9	40,4	48,1-63,1	57,0-79,2	69,6-103,4

Spacing and edge distance

Min. thickness of concrete slab for $h_{ef,min} - h_{ef,max}$	h_{min}	[mm]	100-190	100-230	102-272	111-316	120-360	138-448	164-564	182-630	208-720
Minimum spacing	s_{min}	[mm]	40	50	60	70	80	100	125	140	160
Minimum edge distance	c_{min}	[mm]	40	50	60	70	80	100	125	140	160

Installation parameters

Drill hole diameter	d_o	[mm]	12	14	16	18	20	24	32	35	40
Range of drill hole depth for $h_{ef,min} - h_{ef,max}$	h_o	[mm]	60 - 160	60 - 200	70 - 240	75 - 280	80 - 320	90 - 400	100 - 500	112 - 560	128 - 640

¹⁾ Max. long term temperature / max. short term temperature
Higher concrete strength may lead to higher approved loads. Technical data for water-filled drill holes see approval.

For anchor designing, an easy to operate Software is available on request or can be downloaded at www.mkt.de

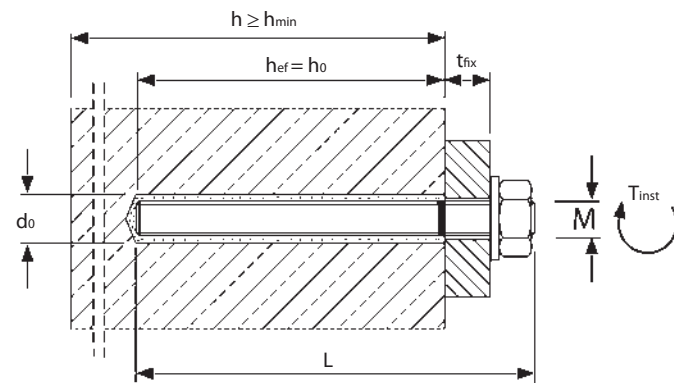

Installation parameters and amount of adhesive for post-installed rebar connections

Rebar connection VMU plus

Rebar-Ø	[mm]	8	10	12	14	16	20	22	24	25
Drill hole-Ø	d_o [mm]	12	14	16	18	20	25/26 ¹⁾	28	32	32
Amount of adhesive/100 mm setting depth	[ml]	7,5	9,0	10,6	12,1	13,6	21,2	28,3	42,2	37,6

¹⁾Compressed air drill



Extract from Permissible Service Conditions of ETA-11/0514 for Post-installed Rebar Connections with Injection System VMU plus

Concrete Strength		C12/15	C16/20	C20/25	C25/30	C30/37	C35/45	C40/50	C45/55	C50/60
Design value of bond strength $f_{bd}^{1)}$ [N/mm ²]	Hammer and pneumatic drilling	1,6	2,0	2,3	2,7	3,0	3,4	3,7	4,0	4,3

¹⁾ The values f_{bd} are valid for "good" bond conditions according to EN 1992-1-1:2004.

Installation in concrete and solid base material

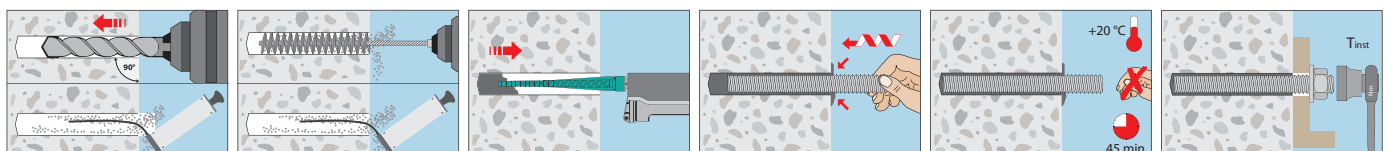

Extract from Permissible Service Conditions of European Technical Assessment ETA-13/0909

 Approved loads for single anchor without influence of spacing and edge distance. Butt joint and horizontal joint with adhesive. (Temperature range -40°C to $+24^{\circ}\text{C}/+40^{\circ}\text{C}^{1)}$ – use category dry/dry). Total safety factor as per ETAG included (γ_M and γ_P).

Injection system VMU plus, solid base material without perfo sleeve²⁾
Clay solid brick Mz-DF according EN 771-1, Bulk density ρ : 1,6 kg/dm³, Minimum brick size: 240x115x55 mm (e.g. Unipor)

Threaded Stud: Steel: \geq FKL 5.8, A4, HCR: \geq FKL 70			M8	M10	M12	M16	IG-M6	IG-M8	IG-M10
Anchorage depth	h_{ef}	[mm]	80	90	100	100	90	100	100
Spacing	s_{cr}	[mm]	240	270	300	300	270	300	300
Minimum spacing	s_{min}	[mm]	120	120	120	120	120	120	120
Edge distance	c_{cr}	[mm]	120	135	150	150	135	150	150
Minimum edge distance	c_{min}	[mm]	60	60	60	60	60	60	60
Approved tension load for compressive strength	$f_b \geq 10 \text{ N/mm}^2$	appr. N [kN]	1,00	1,00	1,14	1,14	1,00	1,14	1,14
	$f_b \geq 20 \text{ N/mm}^2$	appr. N [kN]	1,29	1,57	1,71	1,71	1,57	1,71	1,71
	$f_b \geq 28 \text{ N/mm}^2$	appr. N [kN]	1,57	1,71	1,94	1,94	1,71	1,94	1,94
Approved shear load for compressive strength	$f_b \geq 10 \text{ N/mm}^2$	appr. V [kN]	1,00	1,00	1,00	1,57	1,00	1,00	1,57
	$f_b \geq 20 \text{ N/mm}^2$	appr. V [kN]	1,43	1,43	1,43	2,29	1,43	1,43	2,29
	$f_b \geq 28 \text{ N/mm}^2$	appr. V [kN]	1,57	1,57	1,57	2,57	1,57	1,57	2,57
Drilling method							Hammer drilling		

Calcium silicate solid brick KS-NF according EN 771-2, Bulk density ρ : 2,0 kg/dm³, Minimum brick size: 240x115x71 mm (e.g. Wemding)

Threaded Stud: Steel: \geq FKL 5.8, A4, HCR: \geq FKL 70			M8	M10	M12	M16	IG-M6	IG-M8	IG-M10
Anchorage depth	h_{ef}	[mm]	80	90	100	100	90	100	100
Spacing	s_{cr}	[mm]	240	270	300	300	270	300	300
Minimum spacing	s_{min}	[mm]	120	120	120	120	120	120	120
Edge distance	c_{cr}	[mm]	120	135	150	150	135	150	150
Minimum edge distance	c_{min}	[mm]	60	60	60	60	60	60	60
Approved tension load for compressive strength	$f_b \geq 10 \text{ N/mm}^2$	appr. N [kN]	1,29	1,29	1,29	1,00	1,29	1,29	1,00
	$f_b \geq 20 \text{ N/mm}^2$	appr. N [kN]	1,71	1,71	1,71	1,43	1,71	1,71	1,43
	$f_b \geq 27 \text{ N/mm}^2$	appr. N [kN]	2,00	2,00	2,00	1,71	2,00	2,00	1,71
Approved shear load for compressive strength	$f_b \geq 10 \text{ N/mm}^2$	appr. V [kN]	0,71	0,86	0,71	0,71	0,86	0,71	0,71
	$f_b \geq 20 \text{ N/mm}^2$	appr. V [kN]	1,14	1,29	1,14	1,14	1,29	1,14	1,14
	$f_b \geq 27 \text{ N/mm}^2$	appr. V [kN]	1,29	1,57	1,29	1,29	1,57	1,29	1,29
Drilling method							Hammer drilling		

Brickwork of solid lightweight concrete LAC according EN 771-3, Bulk density ρ : 0,6 kg/dm³, Minimum brick size: 300x123x248 mm (e.g. Bisotherm)

Threaded Stud: Steel: \geq FKL 5.8, A4, HCR: \geq FKL 70			M8	M10	M12	M16	IG-M6	IG-M8	IG-M10
Anchorage depth	h_{ef}	[mm]	80	90	100	100	90	100	100
Spacing	s_{cr}	[mm]	240	270	300	300	270	300	300
Minimum spacing	s_{min}	[mm]	120	120	120	120	120	120	120
Edge distance	c_{cr}	[mm]	120	135	150	150	135	150	150
Minimum edge distance	c_{min}	[mm]	60	60	60	60	60	60	60
Approved tension load for compressive strength	$f_b \geq 2 \text{ N/mm}^2$	appr. N [kN]	0,86	0,86	1,00	0,86	0,86	1,00	0,86
	$f_b \geq 2 \text{ N/mm}^2$	appr. V [kN]	0,86	0,86	0,86	0,86	0,86	0,86	0,86
Drilling method							Rotary drilling		

Autoclaved aerated concrete AAC6 according EN 771-4, Bulk density ρ : 0,6 kg/dm³, Minimum brick size: 499x240x249 mm (e.g. Porit)

Threaded Stud: Steel: \geq FKL 5.8, A4, HCR: \geq FKL 70			M8	M10	M12	M16	IG-M6	IG-M8	IG-M10
Anchorage depth	h_{ef}	[mm]	80	90	100	100	90	100	100
Spacing	s_{cr}	[mm]	240	270	300	300	270	300	300
Minimum spacing	s_{min}	[mm]	100	100	100	100	100	100	100
Edge distance	c_{cr}	[mm]	120	135	150	150	135	150	150
	$c_{min,N}$	[mm]	75	75	75	75	75	75	75
	$c_{min,v,II}^{3)}$	[mm]	75	75	75	75	75	75	75
Minimum edge distance	$c_{min,v,I}^{4)}$	[mm]	120	135	150	150	135	150	150
	h_{min}	[mm]	110	120	130	130	120	130	130
Approved tension load for compressive strength	$f_b \geq 6 \text{ N/mm}^2$	appr. N [kN]	0,89	1,43	1,79	2,32	1,43	1,79	2,32
	$f_b \geq 6 \text{ N/mm}^2$	appr. V [kN]	2,14	3,57	3,57	3,57	2,86	3,57	3,57
Drilling method							Rotary drilling		

Installation parameters in solid base material (without Perfo Sleeve)

Threaded Stud: Steel: \geq FKL 5.8, A4, HCR: \geq FKL 70			M8	M10	M12	M16	IG-M6	IG-M8	IG-M10
Drill hole diameter	d_o	[mm]	10	12	14	18	12	14	18
Depth of drill hole	h_o	[mm]	80	90	100	100	90	100	100
Minimum wall thickness	h_{min}	[mm]	110	120	130	130	120	130	130
Clearance hole in the fixture	$d_f \leq$	[mm]	9	12	14	18	7	9	12
Diameter of cleaning brush	$d_b \geq$	[mm]	12	14	16	20	14	16	20
Installation torque	$T_{inst,max}$	[Nm]	2 (14 for clay solid brick Mz-DF)						
Amount of adhesive per drill hole		[ml]	5,2	7,3	9,8	13,6	7,3	9,8	13,6
Drill holes per cartridge VMU plus	280 / 300	[pcs.]	46 / 50	33 / 36	24 / 26	18 / 19	33 / 36	24 / 26	18 / 19
Drill holes per cartridge VMU plus	345 / 410	[pcs.]	59 / 71	42 / 51	31 / 38	22 / 27	42 / 51	31 / 38	22 / 27

¹⁾Max. long term temperature/max. short term temperature

²⁾Installation with perforated sleeve allowed; technical data, see ETA-13/0909

³⁾Minimum edge distance $c_{min,v,II}$ for shear loads parallel to free edge

⁴⁾Minimum edge distance $c_{min,v,I}$ for shear loads perpendicular to free edge



Extract from Permissible Service Conditions of European Technical Assessment ETA-13/0909

Approved loads for single anchor without influence of spacing and edge distance. Butt joint and horizontal joint with adhesive. (Temperature range -40°C to +24°C/+40°C¹⁾ – use category dry/dry). Total safety factor as per ETAG included (γ_{VM} and γ_{p}).

Injection system VMU plus, perforated brick with Perfo Sleeve

Clay hollow brick Porotherm Homebric according EN 771-1, Bulk density ρ : 0,7 kg/dm³, Minimum brick size: 500x200x299mm (e.g. Wienerberger)

Threaded Stud: Steel: \geq FKL 5.8, A4, HCR: \geq FKL 70			M8	M8 / M10		M12 / M16		IG-M6	IG-M8 / IG-M10	
Perfo Sleeve VM-SH			12x80	16x85	16x130	20x85	20x130	16x85	20x85	
Anchorage depth	h_{ef}	[mm]	80	85	130	85	130	85	85	
Spacing parallel to horizontal joint	$s_{cr,II}$	[mm]	500	500	500	500	500	500	500	
Spacing perpendicular to horizontal joint	$s_{cr,I}$	[mm]	300	300	300	300	300	300	300	
Minimum spacing	s_{min}	[mm]	100	100	100	100	100	100	100	
Edge distance	c_{cr}	[mm]	100	100	100	120	120	100	120	
Minimum edge distance	$c_{min}^{2)}$	[mm]	100	100	100	120	120	100	120	
Approved tension load for compressive strength	$f_b \geq 4$ N/mm ²	appr. N	[kN]	0,26	0,26	0,34	0,26	0,34	0,26	0,26
	$f_b \geq 6$ N/mm ²	appr. N	[kN]	0,26	0,26	0,34	0,26	0,34	0,26	0,26
	$f_b \geq 10$ N/mm ²	appr. N	[kN]	0,34	0,34	0,43	0,34	0,43	0,34	0,34
Approved shear load for compressive strength	$f_b \geq 4$ N/mm ²	appr. V	[kN]	0,57	0,57	0,57	0,71	0,71	0,57	0,71
	$f_b \geq 6$ N/mm ²	appr. V	[kN]	0,71	0,71	0,71	0,86	0,86	0,71	0,86
	$f_b \geq 10$ N/mm ²	appr. V	[kN]	0,86	0,86	1,00	1,14	1,14	0,86	1,14

Clay hollow brick HLZ-16-DF according EN 771-1, Bulk density ρ : 0,8 kg/dm³, Minimum brick size: 497x240x238 mm (e.g. Unipor)

Threaded Stud: Steel: \geq FKL 5.8, A4, HCR: \geq FKL 70			M8	M8 / M10		M12 / M16		IG-M6	IG-M8 / IG-M10		
Perfo Sleeve VM-SH			12x80	16x85	16x130	20x85	20x130	20x200	16x85	20x85	
Anchorage depth	h_{ef}	[mm]	80	85	130	85	130	200	85	85	
Spacing parallel to horizontal joint	$s_{cr,II}$	[mm]	497	497	497	497	497	497	497	497	
Spacing perpendicular to horizontal joint	$s_{cr,I}$	[mm]	238	238	238	238	238	238	238	238	
Minimum spacing	s_{min}	[mm]	100	100	100	100	100	100	100	100	
Edge distance	c_{cr}	[mm]	100	100	100	120	120	120	100	120	
Minimum edge distance	$c_{min}^{2)}$	[mm]	100	100	100	120	120	120	100	120	
Approved tension load for compressive strength	$f_b \geq 6$ N/mm ²	appr. N	[kN]	0,71	0,71	1,00	0,71	1,00	1,00	0,71	0,71
	$f_b \geq 8$ N/mm ²	appr. N	[kN]	0,86	0,86	1,29	0,86	1,29	1,29	0,86	0,86
	$f_b \geq 12$ N/mm ²	appr. N	[kN]	1,00	1,00	1,43	1,00	1,43	1,43	1,00	1,00
	$f_b \geq 14$ N/mm ²	appr. N	[kN]	1,14	1,14	1,57	1,14	1,57	1,57	1,14	1,14
Approved shear load for compressive strength	$f_b \geq 6$ N/mm ²	appr. V	[kN]	0,71	1,29	1,29	1,43	1,71	1,71	1,29	1,43
	$f_b \geq 8$ N/mm ²	appr. V	[kN]	0,86	1,57	1,57	1,71	2,00	2,00	1,57	1,71
	$f_b \geq 12$ N/mm ²	appr. V	[kN]	1,14	1,86	1,86	2,00	2,57	2,57	1,86	2,00
	$f_b \geq 14$ N/mm ²	appr. V	[kN]	1,14	1,86	1,86	2,00	2,57	2,57	1,86	2,00

Clay hollow brick Doppio Uni according EN 771-1, Bulk density ρ : 0,9 kg/dm³, Minimum brick size: 250x120x120 mm (e.g. Wienerberger)

Threaded Stud: Steel: \geq FKL 5.8, A4, HCR: \geq FKL 70			M8	M8 / M10		M12 / M16		IG-M6	IG-M8 / IG-M10		
Perfo Sleeve VM-SH			12x80	16x85	16x130	20x85	20x130	20x200	16x85	20x85	
Anchorage depth	h_{ef}	[mm]	80	85	130	85	130	200	85	85	
Spacing parallel to horizontal joint	$s_{cr,II}$	[mm]	250	250	250	250	250	250	250	250	
Spacing perpendicular to horizontal joint	$s_{cr,I}$	[mm]	120	120	120	120	120	120	120	120	
Min. spacing parallel to horizontal joint	$s_{min,II}$	[mm]	100	100	100	100	100	100	100	100	
Min. Perpendicular to horizontal joint spacing	$s_{min,I}$	[mm]	120	120	120	120	120	120	120	120	
Edge distance	c_{cr}	[mm]	100	100	100	120	120	120	100	120	
Minimum edge distance	$c_{min}^{2)}$	[mm]	60	60	60	60	60	60	60	60	
Approved tension load for compressive strength	$f_b \geq 10$ N/mm ²	appr. N	[kN]	0,17	0,17	0,17	0,17	0,17	0,17	0,17	0,17
	$f_b \geq 16$ N/mm ²	appr. N	[kN]	0,21	0,21	0,21	0,21	0,21	0,21	0,21	0,21
	$f_b \geq 20$ N/mm ²	appr. N	[kN]	0,26	0,26	0,26	0,26	0,26	0,26	0,26	0,26
	$f_b \geq 28$ N/mm ²	appr. N	[kN]	0,34	0,34	0,34	0,34	0,34	0,34	0,34	0,34
Approved shear load for compressive strength	$f_b \geq 10$ N/mm ²	appr. V	[kN]	0,43	0,43	0,43	0,43	0,43	0,43	0,43	0,43
	$f_b \geq 16$ N/mm ²	appr. V	[kN]	0,57	0,57	0,57	0,57	0,57	0,57	0,57	0,57
	$f_b \geq 20$ N/mm ²	appr. V	[kN]	0,57	0,57	0,57	0,57	0,57	0,57	0,57	0,57
	$f_b \geq 28$ N/mm ²	appr. V	[kN]	0,71	0,71	0,71	0,71	0,71	0,71	0,71	0,71

Calcium silicate hollow brick KSL-3DF according EN 771-2, Bulk density ρ : 1,4 kg/dm³, Minimum brick size: 240x175x113 mm (e.g. Wemding)

Threaded Stud: Steel: \geq FKL 5.8, A4, HCR: \geq FKL 70			M8	M8 / M10		M12 / M16		IG-M6	IG-M8 / IG-M10		
Perfo Sleeve VM-SH			12x80	16x85	16x130	20x85	20x130	20x200	16x85	20x85	
Anchorage depth	h_{ef}	[mm]	80	85	130	85	130	200	85	85	
Spacing parallel to horizontal joint	$s_{cr,II}$	[mm]	240	240	240	240	240	240	240	240	
Spacing perpendicular to horizontal joint	$s_{cr,I}$	[mm]	120	120	120	120	120	120	120	120	
Minimum spacing	s_{min}	[mm]	120	120	120	120	120	120	120	120	
Edge distance	c_{cr}	[mm]	100	100	100	120	120	120	100	120	
Minimum edge distance	c_{min}	[mm]	60	60	60	60	60	60	60	60	
Approved tension load for compressive strength	$f_b \geq 8$ N/mm ²	appr. N	[kN]	0,43	0,43	0,43	1,29	1,29	1,29	0,43	1,29
	$f_b \geq 12$ N/mm ²	appr. N	[kN]	0,57	0,57	0,71	1,71	1,71	1,71	0,57	1,71
	$f_b \geq 14$ N/mm ²	appr. N	[kN]	0,71	0,71	0,71	1,86	1,86	1,86	0,71	1,86
Approved shear load for compressive strength	$f_b \geq 8$ N/mm ²	appr. V	[kN]	0,71	1,14	1,14	1,14	1,14	1,14	1,14	1,14
	$f_b \geq 12$ N/mm ²	appr. V	[kN]	0,86	1,29	1,29	1,29	1,29	1,29	1,29	1,29
	$f_b \geq 14$ N/mm ²	appr. V	[kN]	1,00	1,71	1,71	1,71	1,71	1,71	1,71	1,71

¹⁾Max. long term temperature/max. short term temperature

²⁾For $V_{Rk,c}$: c_{min} see ETAG 029, Annex C

Extract from Permissible Service Conditions of European Technical Assessment ETA-13/0909

 Approved loads for single anchor without influence of spacing and edge distance. Butt joint and horizontal joint with adhesive. (Temperature range -40°C to $+24^{\circ}\text{C}/+40^{\circ}\text{C}^{1)}$ – use category dry/dry). Total safety factor as per ETAG included (γ_M and γ_P).

Injection system VMU plus, perforated brick with Perfo Sleeve
Calcium silicate hollow brick KSL-12DF according EN 771-2, Bulk density ρ : 1,4 kg/dm³, Minimum brick size: 498x175x238 mm (e.g. Wemding)

			M8	M8 / M10		M12 / M16		IG-M6	IG-M8 / IG-M10
Threaded Stud: Steel: \geq FKL 5.8, A4, HCR: \geq FKL 70									
Perfo Sleeve VM-SH			12x80	16x85	16x130	20x85	20x130	16x85	20x85
Anchorage depth	hef	[mm]	80	85	130	85	130	85	85
Spacing parallel to horizontal joint	Scr	[mm]	498	498	498	498	498	498	498
Spacing perpendicular to horizontal joint	Scr _⊥	[mm]	238	238	238	238	238	238	238
Minimum spacing	S _{min}	[mm]	120	120	120	120	120	120	120
Edge distance	C _{cr}	[mm]	100	100	100	120	120	100	120
Minimum edge distance	C _{min} ²⁾	[mm]	100	100	100	120	120	100	120
Min. thickness of base material (masonry)	h _{min}	[mm]	115	115	175	115	175	115	115
Approved tension load for compressive strength	f _b \geq 10 N/mm ²	appr. N	[kN]	0,17	0,17	0,71	0,43	0,71	0,43
	f _b \geq 12 N/mm ²	appr. N	[kN]	0,21	0,21	0,86	0,43	0,86	0,43
	f _b \geq 16 N/mm ²	appr. N	[kN]	0,26	0,26	1,14	0,57	1,14	0,57
Approved shear load for compressive strength	f _b \geq 10 N/mm ²	appr. V	[kN]	0,71	1,57	1,57	1,57	1,57	1,57
	f _b \geq 12 N/mm ²	appr. V	[kN]	0,86	1,86	1,86	1,86	1,86	1,86
	f _b \geq 16 N/mm ²	appr. V	[kN]	1,00	2,29	2,29	2,29	2,29	2,29

Hollow lightweight concrete Bloc creux B40 according EN 771-3, Bulk density ρ : 0,8 kg/dm³, Minimum brick size: 494x200x190 mm (e.g. Sepa)

			M8	M8 / M10		M12 / M16		IG-M6	IG-M8 / IG-M10
Threaded Stud: Steel: \geq FKL 5.8, A4, HCR: \geq FKL 70									
Perfo Sleeve VM-SH			12x80	16x85	16x130	20x85	20x130	16x85	20x85
Anchorage depth	hef	[mm]	80	85	130	85	130	85	85
Spacing parallel to horizontal joint	Scr	[mm]	494	494	494	494	494	494	494
Spacing perpendicular to horizontal joint	Scr _⊥	[mm]	190	190	190	190	190	190	190
Minimum spacing	S _{min}	[mm]	100	100	100	100	100	100	100
Edge distance	C _{cr}	[mm]	100	100	100	120	120	100	120
Minimum edge distance	C _{min} ²⁾	[mm]	100	100	100	120	120	100	120
Min. thickness of base material (masonry)	h _{min}	[mm]	115	115	175	115	175	115	115
Approved tension load for compressive strength	f _b \geq 4 N/mm ²	appr. N	[kN]	0,34	0,34	0,34	0,34	0,34	0,34
Approved shear load for compressive strength	f _b \geq 4 N/mm ²	appr. V	[kN]	0,86	0,86	0,86	0,86	0,86	0,86

Installation parameter in solid brickwork with a Perfo Sleeve

			M8	M8 / M10		M12 / M16		IG-M6	IG-M8 / IG-M10		
Threaded Stud: Steel: \geq FKL 5.8, A4, HCR: \geq FKL 70											
Perfo Sleeve VM-SH			12x80	16x85	16x130	20x85	20x130	20x200	16x85	20x85	
Drill hole diameter	d _o	[mm]	12	16	16	20	20	20	16	20	
Depth of drill hole	h _o	[mm]	85	90	135	90	135	205	90	90	
Minimum wall thickness	h _{min}	[mm]	115	115	175	115	175	240	115	115	
Clearance hole in the fixture	df \leq	[mm]	9	9 / 12	9 / 12	14 / 18	14 / 18	14 / 18	7	9 / 12	
Diameter of cleaning brush	d _b \geq	[mm]	14	18	18	22	22	22	18	22	
Installation torque	T _{inst,max}	[Nm]	2								
Amount of adhesive per drill hole	[ml]		11,2	24,9	38,0	41,1	62,9	96,7	24,9	41,1	
Drill holes per cartridge VMU plus 280 / 300	[pcs.]		21 / 23	9 / 10	6 / 6	5 / 6	3 / 4	2 / 2	9 / 10	5 / 6	
Drill holes per cartridge VMU plus 345 / 410	[pcs.]		27 / 33	12 / 14	8 / 9	7 / 9	4 / 5	3 / 3	12 / 14	7 / 9	
Drilling method			Rotary drilling								

¹⁾Max. long term temperature/max. short term temperature

²⁾For V_{Rk,c}: C_{min} see ETAG 029, Annex C

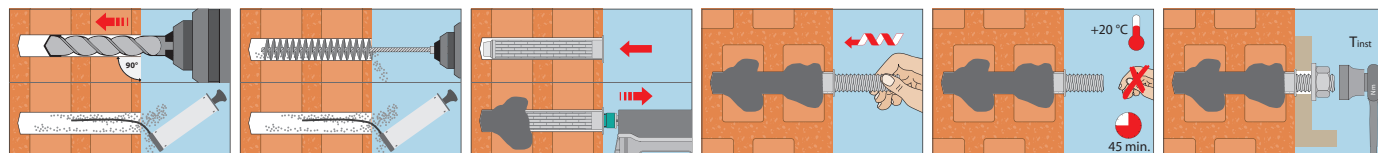
Installation

Injection System VM-EA

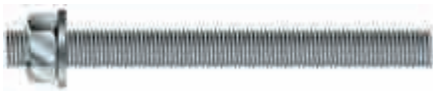

Threaded stud VMU-A
for concrete and brickwork



Threaded stud VM-A
1 meter length, to be cut to the required length, for concrete and brickwork



Perfo sleeve VM-SH
for hollow block



Cartridge VM-EA 300
Foil tube cartridge suitable for silicone guns
Content: 300 ml styrene-free

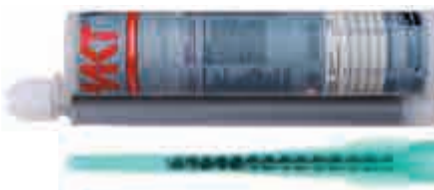

Cartridge VM-EA 345
Side-by-side cartridge
Content: 345ml styrene-free



Cartridge VM-EA 420
Coaxial cartridge
Content: 420ml styrene-free

Range of loading: 0,1 kN - 176,38 kN

Concrete quality: C20/25 - C50/60

Brickwork: Solid and perforated bricks

**Material: Steel zinc plated, stainless steel A4
On demand: Steel hot dip galvanized,
Stainless steel HCR**

Description

The Injection System VM-EA is used for fixations in non-cracked concrete and brickwork. It is composed of a styrene-free injection adhesive, based on epoxy acrylate, in a cartridge, MKT anchor rods VMU-A, V-A or with threaded studs with manufacturer's certificate (e.g. MKTVM-A) as well as nut and washer. Applications in perforated brick additionally require a perfo sleeve.



M8-M16

Advantages

- Versatile injection system for different applications in concrete and masonry
- Approved for non-cracked concrete
- Approved application in wet concrete and water-filled drill holes
- Approved for autoclaved aerated concrete, solid and perforated brickwork in wet or dry condition
- Approved with standard threaded studs (test certificate required)
- Approved with shortenable perfo sleeve VM-SH16 x 130/330 for bridging structures over insulation systems and other soft substrates
- Base material temperature during installation -5°C to +40°C
- Ambient temperature when completely cured -40°C to +80°C
- Variable anchorage depths for more flexibility
- Opened cartridges can be re-used with a new mixer nozzle
- Styrene-free

Applications

Fastenings in non-cracked concrete:

Base plates, supports, wall brackets, mounting of joint tapes.

Fastenings in brickwork:

Canopies, door and window frames, facade substructures, battens, gates etc.

With the perfo sleeve VM-SH 16 x 130/330, lightweight fixations in perforated brick are also possible on insulation boards.

Injection Cartridge VM-EA



- modified epoxy acrylate, styrene-free
- Approved for use in non-cracked concrete and in brickwork

Description	Ref. No.	Content ml	Content of master box pcs	Weight per master box kg	Weight per piece kg
Cartridge VM-EA 300	28253101	300	12	6,40	0,53
Cartridge VM-EA 345	28255211	345	12	8,00	0,65
Cartridge VM-EA 420	28256201	420	12	10,1	0,83
Static mixer VM-X	28305111	-	12	0,12	0,01
Mixer extension VM-XE 10/200 (200mm)	28306011	-	12	-	0,01
Mixer extension VM-XE 10/500 (500mm)	85951101	-	10	-	0,02

One static mixer comes with each cartridge. Usable length of the static mixer see page 106.

NEW

Curing Time Injection Adhesive VM-EA

- Cartridge temperature during installing + 5°C to + 40°C

Temperature (°C) in the drill hole	Gel time	Curing time	
		dry base material	wet base material
-5°C bis - 1°C	90 min	6 h	12 h
0°C bis + 4°C	45 min	3 h	6 h
+ 5°C bis + 9°C	25 min	2 h	4 h
+ 10°C bis + 14°C	20 min	100 min	200 min
+ 15°C bis + 19°C	15 min	80 min	160 min
+ 20°C bis + 29°C	6 min	45 min	90 min
+ 30°C bis + 34°C	4 min	25 min	50 min
+ 35°C bis + 39°C	2 min	20 min	40 min

Storage Box



- In stackable multi-purpose container
- Storage Box, the container for various items
- H x W x D: 220 x 400 x 300 mm

Description	Ref. No.	Content	Quantity Pcs.	Weight per Box kg
Storage Box VM-EA 300	28998201	Cartridge VM-EA 300	20	12,8
		Static mixer VM-X	40	
Storage Box VM-EA 345	28998501	Cartridge VM-EA 345	20	15,3
		Static mixer VM-X	40	
Storage Box VM-EA 420	28998801	Cartridge VM-EA 420	20	18,0
		Static mixer VM-X	40	

NEW

Threaded Studs for applications in non-cracked concrete and brickwork

Threaded Stud VMU-A

Steel, zinc plated 5.8
Dimensions see page 107



- For use in structures subject to dry internal conditions
- Steel, zinc plated 8.8 on demand

Threaded Stud VMU-A A4

Stainless steel A4
Dimensions see page 107



- For use in structures subject to dry internal conditions or external atmospheric exposure
- Stainless steel HCR on demand

Threaded Stud V-A

Steel, zinc plated 5.8
Dimensions see page 144



- For use in structures subject to dry internal conditions
- Steel, zinc plated 8.8 on demand

Threaded Stud V-A A4

Stainless steel A4
Dimensions see page 144



- For use in structures subject to dry internal conditions or external atmospheric exposure

Threaded Stud V-A fvz

Steel, hot dip galvanized 5.8
Dimensions see page 144



- For use in structures subject to dry internal conditions
- Steel hot dip galvanized 8.8 on demand

Threaded Stud V-A HCR

Stainless steel HCR
Dimensions see page 144



- For use in particularly corrosive environments
- High corrosion resistant steel 1.4529 (HCR)

Threaded studs for applications in non-cracked concrete and brickwork

Threaded stud VM-A

Steel 5.8, zinc plated
Dimensions see page 108



- For use in structures subject to dry internal conditions
- Threaded studs, of 1 meter length, to be cut to the required length
- Comes with manufacturer's certificate (3.1 EN 10204) in every package

Threaded stud VM-A

Stainless steel A4
Dimensions see page 108



- For use in structures subject to dry internal conditions or external atmospheric exposure
- Threaded studs, of 1 meter length, to be cut to the required length
- Comes with manufacturer's certificate (3.1 EN 10204) in every package

Threaded stud VM-A

Steel 8.8, zinc plated
Dimensions see page 108



- For use in structures subject to dry internal conditions
- Threaded studs, of 1 meter length, to be cut to the required length
- Comes with manufacturer's certificate (3.1 EN 10204) in every package

Perfo sleeve VM-SH



- Material: Polypropylene
- Approved for solid and perforated bricks

Description	Ref. No.	Drill hole Ø x Depth mm	For threaded studs Ø mm	Package content pcs.	Weight per pkg. kg
VM-SH 12 x 80	28151201	12 x 85	M8	10	0,02
VM-SH 16 x 85	28152001	16 x 90	M8 / M10	10	0,03
VM-SH 16 x 130	28153001	16 x 135	M8 / M10	10	0,04
NEW VM-SH 16 x 130/330	28153201	16 x 135 + t _{fix} ¹⁾	M8 / M10	10	0,16
VM-SH 20 x 85	28154001	20 x 90	M12 / M16	10	0,04
VM-SH 20 x 130	28154301	20 x 135	M12 / M16	10	0,07
VM-SH 20 x 200	28154601	20 x 205	M12 / M16	10	0,10

¹⁾ t_{fix} = shortened length perfo sleeves -130 mm

Drill hole cleaning

Cleaning brush RB M6



- With connection thread M6
- Extension for large drill hole depths
- Separate SDS plus adapter with internal thread M6 for SDS plus drill holder
- For drilling machines with keyed chuck

Description	Ref. No.	Suitable for drill holes Ø mm	Total length of brush mm	Suitable for		Package content pcs.	Weight per piece kg
				Threaded stud	Perfo sleeve VM-SH		
RB 10 M6	33510101	10	130	M8	-	1	0,05
RB 12 M6	33512101	12	140	M10	12x80	1	0,05
RB 14 M6	33514101	14	180	M12	-	1	0,05
RB 16 M6	33516101	16	200	-	16x85, 16x130, 16x130/330	1	0,05
RB 18 M6	33518101	18	200	M16	-	1	0,05
RB 20 M6	33520101	20	220	-	20x85, 20x130, 20x200	1	0,06
RB 24 M6	33529101	24	250	M20	-	1	0,06
RB 28 M6	33528101	28	260	M24	-	1	0,06

Blow-out pump VM-AP



→ For approval-compliant air-cleaning of drill holes with a diameter in brickwork and concrete up to 20 mm and a maximum drill hole depth of 240 mm (VM-EA)

→ For best drill hole cleaning, the hose must reach the bottom of the drill hole

Description	Ref. No.	Hose Ø mm	For drill hole Ø mm	Max. drill hole depth ²⁾ mm	Pkg. cont. pcs	Weight per piece kg
Blow-out pump VM-AP 360	33200101	8	8 ¹⁾ -20	330	1	0,27

¹⁾With extension tube Ø 6 x 100mm

²⁾For through fastening: Maximum drill hole depth through fixture

Air gun VM-ABP



→ For approval-compliant drill hole cleaning with compressed air for drill holes with a diameter larger than 6 mm

→ For best drill hole cleaning, the nozzle of the air gun must reach the bottom of the drill hole

Description	Ref. No.	Nozzle-ø mm	For drill hole Ø mm	Max. drill hole depth ¹⁾ mm	Pkg. cont. pcs.	Weight per piece kg
VM-ABP 200	33090101	5	6-20	240	1	0,55
VM-ABP 250	33100101	16	18-40	240	1	1,00
VM-ABP 500	33106101	16	18-40	480	1	1,30

¹⁾For through fastening: Maximum drill hole depth through fixture

Dispenser VM-P Profi



→ Professional dispenser with an ideal center of gravity for more comfortable working

→ Automatic pressure release for minimum adhesive overrun

Description	Ref. No.	Suitable for cartridges	Pkg. cont. pcs	Weight per piece kg
VM-P 345 Profi	28350511	150ml, 280ml, 300ml, 345ml also suitable for silicone cartridges	1	1,00
VM-P 380 Profi	28351001	380ml, 410ml, 420ml	1	1,10

Dispenser VM-P Standard



→ For occasional use, metal version

→ Piston rod with adjusting screw

Description	Ref. No.	Suitable for cartridges	Pkg. cont. pcs	Weight per piece kg
VM-P 345 Standard	28350505	150ml, 280ml, 300ml, 345ml also suitable for silicone cartridges	1	1,00
VM-P 380 Standard	28353005	380ml, 410ml, 420ml	1	1,15

Dispenser VM-P Pneumatic



→ Professional air tool with an optimum center of gravity and quick cartridge exchange

→ Automatic pressure release system reduces adhesive overrun to a minimum

→ Single-hand pressure regulation to adjust the piston speed

→ With compressed air connection nipple

Description	Ref. No.	Suitable for cartridges	max. working pressure 8 bar, 40l/min	Pkg. cont. pcs	Weight per piece kg
VM-P 345 Pneumatic	28350601	280ml, 300ml, 345ml	1	2,41	
VM-P 380 Pneumatic	28352002	380ml, 410ml, 420ml	1	2,00	

Dispenser VM-P Akku



¹⁾ with battery 18V/2,0 Ah

→ Professional, solid battery cartridge dispenser in a plastic case

→ Repeat function, for retrieving the last full quantity

→ Stepless variable pressing speed

→ Overrun-quantity-stop by automatic return after release of the dispensing switch

Description	Ref. No.	Suitable for cartridges	Press-out force kN	Weight ¹⁾ kg	Dimensions ¹⁾ L x B x H mm	Pkg. cont. pcs	Weight per piece kg
VM-P 345 Akku	28350801	345ml	5,0	3,53	395 x 180 x 285	1	7,72
VM-P 380 Akku	28352601	380ml, 410ml, 420ml	3,95	3,62	375 x 180 x 285	1	7,80
Accessories (for all models)							
Replacement battery	28352411		18 V/2,0 Ah			1	1,00
Shoulder strap	28359991		adjustable			1	0,02



Extract from Permissible Service Conditions of European Technical Assessment ETA-16/0898

Approved loads for single anchors without influence of spacing and edge distance in dry or wet concrete for temperature range I -40°C to +24°C/+40°C¹⁾ and for temperature range II -40°C to +50°C/+80°C¹⁾. Total safety factor as per ETAG 001 included (γ_M and γ_P).

Loads and performance data				non-cracked concrete						
Injection System VM-EA, threaded stud Steel 5.8				M8	M10	M12	M16	M20	M24	
Range of anchorage depth	$h_{ef,min} - h_{ef,max}$	[mm]		60 - 160	60 - 200	70 - 240	80 - 320	90 - 400	96 - 480	
Approved tension load for $h_{ef,min} - h_{ef,max}$										
Range of temperature	24°C/40°C ¹⁾	C20/25	appr. N	[kN]	5,1 - 8,7	6,0 - 13,8	8,4 - 20,1	12,8 - 37,4	17,1 - 58,3	18,8 - 84,0
	50°C/80°C ¹⁾	C20/25	appr. N	[kN]	3,9 - 8,7	4,5 - 13,8	6,3 - 20,1	9,6 - 37,4	13,5 - 58,3	17,2 - 84,0
Approved shear load for $h_{ef,min} - h_{ef,max}$										
Range of temperature	24°C/40°C ¹⁾	C20/25	appr. V	[kN]	5,2	8,3	12,0	22,4	35,0	45,2 - 50,4
	50°C/80°C ¹⁾	C20/25	appr. V	[kN]	5,2	8,3	12,0	22,4	32,3 - 35,0	41,4 - 50,4
Injection System VM-EA, threaded stud Steel 8.8				M8	M10	M12	M16	M20	M24	
Range of anchorage depth	$h_{ef,min} - h_{ef,max}$	[mm]		60 - 160	60 - 200	70 - 240	80 - 320	90 - 400	96 - 480	
Approved tension load for $h_{ef,min} - h_{ef,max}$										
Range of temperature	24°C/40°C ¹⁾	C20/25	appr. N	[kN]	5,1 - 13,6	6,0 - 19,9	8,4 - 28,7	12,8 - 51,1	17,1 - 79,8	18,8 - 114,9
	50°C/80°C ¹⁾	C20/25	appr. N	[kN]	3,9 - 10,4	4,5 - 15,0	6,3 - 21,5	9,6 - 38,3	13,5 - 59,8	17,2 - 86,2
Approved shear load for $h_{ef,min} - h_{ef,max}$										
Range of temperature	24°C/40°C ¹⁾	C20/25	appr. V	[kN]	8,4	13,3	19,3	30,6 - 35,9	41,1 - 56,0	45,2 - 80,7
	50°C/80°C ¹⁾	C20/25	appr. V	[kN]	8,4	10,8 - 13,3	15,1 - 19,3	23,0 - 35,9	32,3 - 56,0	41,4 - 80,7
Injection System VM-EA, threaded stud Stainless Steel A4, HCR				M8	M10	M12	M16	M20	M24	
Range of anchorage depth	$h_{ef,min} - h_{ef,max}$	[mm]		60 - 160	60 - 200	70 - 240	80 - 320	90 - 400	96 - 480	
Approved tension load for $h_{ef,min} - h_{ef,max}$										
Range of temperature	24°C/40°C ¹⁾	C20/25	appr. N	[kN]	5,1 - 9,8	6,0 - 15,5	8,4 - 22,6	12,8 - 42,1	17,1 - 65,6	18,8 - 94,6
	50°C/80°C ¹⁾	C20/25	appr. N	[kN]	3,9 - 9,8	4,5 - 15,0	6,3 - 21,5	9,6 - 38,3	13,5 - 59,8	17,2 - 86,2
Approved shear load for $h_{ef,min} - h_{ef,max}$										
Range of temperature	24°C/40°C ¹⁾	C20/25	appr. V	[kN]	5,9	9,3	13,5	25,2	39,4	45,2 - 56,7
	50°C/80°C ¹⁾	C20/25	appr. V	[kN]	5,9	9,3	13,5	23,0 - 25,2	32,3 - 39,4	41,4 - 56,7
Spacing and edge distance										
Min. thickness of concrete slab for $h_{ef,min} - h_{ef,max}$	h_{min}	[mm]		100 - 190	100 - 230	100 - 270	116 - 356	138 - 448	152 - 536	
Minimum spacing	s_{min}	[mm]		40	50	60	80	100	120	
Minimum edge distance	c_{min}	[mm]		40	50	60	80	100	120	
Installation parameters										
Diameter of drill hole	d_o	[mm]		10	12	14	18	24	28	
Clearance hole in the fixture	$d_{fr} \leq$	[mm]		9	12	14	18	22	26	
Diameter of brush	$d_b \geq$	[mm]		12	14	16	20	26	30	
Range of drill hole depth for $h_{ef,min} - h_{ef,max}$	h_o	[mm]		60 - 160	60 - 200	70 - 240	80 - 320	90 - 400	96 - 480	
Installation torque	$T_{inst,max}$	[Nm]		10	20	40	80	120	160	
Amount of adhesive per 100mm drill hole depth	[ml]			6,53	8,16	9,82	13,61	26,71	32,25	

¹⁾Max. long term temperature / max. short term temperature
Higher concrete strength may lead to higher approved loads.

Chemical Anchors

Installation in concrete

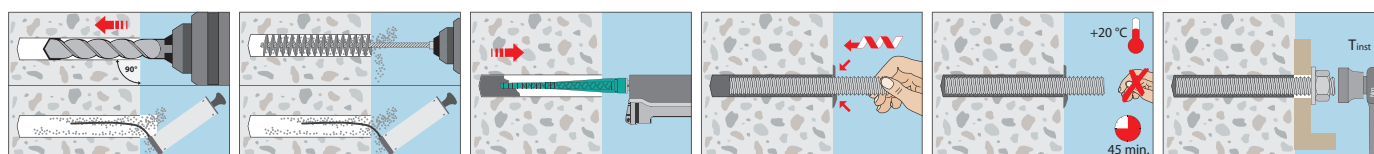

Extract from Permissible Service Conditions of European Technical Assessment ETA-17/0006

Approved loads for single anchor without influence of spacing and edge distance. Butt joint and horizontal joint with adhesive.

 Range of temperature -40°C to $24^{\circ}\text{C}/40^{\circ}\text{C}^{1)}$ – use category dry/dry. Total safety factor as per ETAG 001 included (γ_M and γ_F).

Injection System VM-EA, Solid brick without Perfo Sleeve²⁾
Solid brick Mz-DF according EN 771-1, Bulk density ρ : 1,64 kg/dm³, Minimum brick size: 240x115x55 mm (e.g. Unipor)

Threaded studs ¹⁾ : Steel: \geq FKL 5.8; A4, HCR: \geq FKL 70			M8	M10	M12	M16
Anchorage depth	h_{ef}	[mm]	80	90	100	100
Spacing = Minimum spacing	$s_{cr} = s_{min}$	[mm]	240	270	300	300
Edge distance = Minimum edge distance	$c_{cr} = c_{min}$	[mm]	120	135	150	150
Approved tension load for compressive strength	$f_b \geq 10 \text{ N/mm}^2$	appr. N [kN]	0,4	0,4	0,4	0,7
	$f_b \geq 20 \text{ N/mm}^2$	appr. N [kN]	0,7	0,7	0,6	1,0
	$f_b \geq 28 \text{ N/mm}^2$	appr. N [kN]	0,9	0,9	0,7	1,3
Approved shear load for compressive strength	$f_b \geq 10 \text{ N/mm}^2$	appr. V [kN]	0,9	1,0	1,4	1,4
	$f_b \geq 20 \text{ N/mm}^2$	appr. V [kN]	1,3	1,6	2,1	2,1
	$f_b \geq 28 \text{ N/mm}^2$	appr. V [kN]	1,6	1,9	2,6	2,6
Drilling method			Hammer drilling			
Installation torque	$T_{inst,max}$	[Nm]	6	10	10	10

Calcium silicate solid brick KS-NF according EN 771-2, Bulk density ρ : 2,0 kg/dm³, Minimum brick size: 240x115x71 mm (e.g. Wemding)¹⁾

Threaded studs ¹⁾ : Steel: \geq FKL 5.8; A4, HCR: \geq FKL 70			M8	M10	M12	M16
Anchorage depth	h_{ef}	[mm]	80	90	100	100
Spacing = Minimum spacing	$s_{cr} = s_{min}$	[mm]	240	270	300	300
Edge distance = Minimum edge distance	$c_{cr} = c_{min}$	[mm]	120	135	150	150
Approved tension load for compressive strength	$f_b \geq 10 \text{ N/mm}^2$	appr. N [kN]	0,9	0,9	1,1	0,9
	$f_b \geq 20 \text{ N/mm}^2$	appr. N [kN]	1,3	1,3	1,6	1,3
	$f_b \geq 27 \text{ N/mm}^2$	appr. N [kN]	1,6	1,6	1,9	1,6
Approved shear load for compressive strength	$f_b \geq 10 \text{ N/mm}^2$	appr. V [kN]	0,9	0,9	1,0	1,0
	$f_b \geq 20 \text{ N/mm}^2$	appr. V [kN]	1,3	1,3	1,4	1,4
	$f_b \geq 27 \text{ N/mm}^2$	appr. V [kN]	1,4	1,6	1,7	1,7
Drilling method			Hammer drilling			
Installation torque	$T_{inst,max}$	[Nm]	10	20	20	20

Brickwork of solid lightweight concrete according EN 771-3, Bulk density ρ : 0,63 kg/dm³, Minimum brick size: 300x123x248 mm (e.g. Bisotherm)¹⁾

Threaded studs ¹⁾ : Steel: \geq FKL 5.8; A4, HCR: \geq FKL 70			M8	M10	M12	M16
Anchorage depth	h_{ef}	[mm]	80	90	100	100
Spacing = Minimum spacing	$s_{cr} = s_{min}$	[mm]	240	270	300	300
Edge distance = Minimum edge distance	$c_{cr} = c_{min}$	[mm]	120	135	150	150
Approved tension load for compressive strength	$f_b \geq 2 \text{ N/mm}^2$	appr. N [kN]	0,6	0,6	0,6	0,6
	$f_b \geq 2 \text{ N/mm}^2$	appr. V [kN]	0,9	1,0	1,1	1,1
Drilling method			Rotary drilling			
Installation torque	$T_{inst,max}$	[Nm]	6	6	10	14

Brickwork of solid lightweight concrete Leca Lex harkko RUH-200 according EN 771-3, Bulk density ρ : 0,78 kg/dm³, Minimum brick size: 498x200x195 mm (e.g. Saint-Gobain Weber)¹⁾

Threaded studs ¹⁾ : Steel: \geq FKL 5.8; A4, HCR: \geq FKL 70			M8	M10	M12	M16
Anchorage depth	h_{ef}	[mm]	80	90	100	100
Spacing = Minimum spacing	$s_{cr} = s_{min}$	[mm]	240	270	300	300
Edge distance = Minimum edge distance	$c_{cr} = c_{min}$	[mm]	120	135	150	150
Approved tension load for compressive strength	$f_b \geq 3 \text{ N/mm}^2$	appr. N [kN]	0,6	0,9	0,9	0,9
	$f_b \geq 3 \text{ N/mm}^2$	appr. V [kN]	0,9	1,1	1,1	1,1
Drilling method			Rotary drilling			
Installation torque	$T_{inst,max}$	[Nm]	6	12	14	16

Installation parameters in solid brick without perfo sleeve

Threaded studs: Steel: \geq FKL 5.8; A4, HCR: \geq FKL 70			M8	M10	M12	M16
Diameter of drill hole	d_o	[mm]	10	12	14	18
Drill hole depth	h_o	[mm]	80	90	100	100
Drilling method			s. brick information			
Minimum wall thickness	h_{min}	[mm]	110	120	130	130
Clearance hole in the fixture	$d_{f \leq}$	[mm]	9	12	14	18
Diameter of brush	$d_{b \geq}$	[mm]	12	14	16	20
Installation torque			s. brick information			
Amount of adhesive per drill hole		[ml]	5,2	7,3	9,8	13,6
Drill holes per cartridge	VM-EA 300	[Pcs.]	50	36	26	19
	VM-EA 345	[Pcs.]	59	42	31	22
	VM-EA 420	[Pcs.]	73	52	39	28

¹⁾Max. long term temperature / max. short term temperature

²⁾Installation with perfo sleeve, see ETA-17/0006



Extract from Permissible Service Conditions of European Technical Assessment ETA-17/0006

Approved loads for single anchor without influence of spacing and edge distance. Butt joint and horizontal joint with adhesive.
 Range of temperature -40°C to 24°C/40°C¹⁾ – use category dry/dry. Total safety factor as per ETAG 001 included (γ_{M} and γ_{P}).

Injection System VM-EA, autoclaved aerated concrete without perfo sleeve

Autoclaved aerated concrete block AAC2 according EN 771-4, Bulk density ρ : 0,35 kg/dm³, Minimum brick size: 599x375x249 mm (e.g. Ytong)

			M8	M10	M12	M16
Threaded studs: Steel: \geq FKL 5.8; A4, HCR: \geq FKL 70						
Anchorage depth	h_{ef}	[mm]	80	90	100	100
Spacing = Minimum spacing	$s_{cr} = s_{min}$	[mm]	240	270	300	300
Edge distance = Minimum edge distance	$c_{cr} = c_{min}$	[mm]	120	135	150	150
Approved tension load for compression strength $f_b \geq 2$ N/mm ²	appr. N	[kN]	0,3	0,3	0,5	0,5
Approved shear load for compression strength $f_b \geq 2$ N/mm ²	appr. V	[kN]	0,5	0,7	0,9	1,3
Installation torque	$T_{inst,max}$	[Nm]	2			

Autoclaved aerated concrete block AAC4 according EN 771-4, Bulk density ρ : 0,50 kg/dm³, Minimum brick size: 499x375x249 mm (e.g. Ytong)

			M8	M10	M12	M16
Threaded studs: Steel: \geq FKL 5.8; A4, HCR: \geq FKL 70						
Anchorage depth	h_{ef}	[mm]	80	90	100	100
Spacing = Minimum spacing	$s_{cr} = s_{min}$	[mm]	240	270	300	300
Edge distance = Minimum edge distance	$c_{cr} = c_{min}$	[mm]	120	135	150	150
Approved tension load for compression strength $f_b \geq 4$ N/mm ²	appr. N	[kN]	0,3	0,9	0,9	1,3
Approved shear load for compression strength $f_b \geq 4$ N/mm ²	appr. V	[kN]	0,5	0,7	0,9	1,3
Installation torque	$T_{inst,max}$	[Nm]	2			

Autoclaved aerated concrete block AAC6 according EN 771-4, Bulk density ρ : 0,60 kg/dm³, Minimum brick size: 499x240x249 mm (e.g. Porit)

			M8	M10	M12	M16
Threaded stud: Steel: \geq FKL 5.8; A4, HCR: \geq FKL 70						
Anchorage depth	h_{ef}	[mm]	80	90	100	100
Spacing = Minimum spacing	$s_{cr} = s_{min}$	[mm]	240	270	300	300
Edge distance = Minimum edge distance	$c_{cr} = c_{min}$	[mm]	120	135	150	150
Approved tension load for compression strength $f_b \geq 6$ N/mm ²	appr. N	[kN]	0,7	1,1	1,6	2,0
Approved shear load for compression strength $f_b \geq 6$ N/mm ²	appr. V	[kN]	2,0	3,2	3,2	3,9
Installation torque	$T_{inst,max}$	[Nm]	2			

Installation parameters autoclaved aerated concrete without perfo sleeve

			M8	M10	M12	M16
Threaded studs: Steel: \geq FKL 5.8; A4, HCR: \geq FKL 70						
Diameter of drill hole	d_o	[mm]	10	12	14	18
Drill hole depth	h_o	[mm]	80	90	100	100
Drilling method			Rotary drilling			
Minimum wall thickness	h_{min}	[mm]	110	120	130	130
Clearance hole in the fixture	$d_{f \leq}$	[mm]	9	12	14	18
Diameter of brush	$d_b \geq$	[mm]	12	14	16	20
Installation torque	$T_{inst,max}$	[Nm]	2	2	2	2
Amount of adhesive per drill hole		[ml]	5,2	7,3	9,8	13,6
Drill holes per cartridge	VM-EA 300	[Pcs.]	50	36	26	19
	VM-EA 345	[Pcs.]	59	42	31	22
	VM-EA 420	[Pcs.]	73	52	39	28

¹⁾Max. long term temperature / max. short term temperature

Installation in autoclaved aerated concrete and solid brick without perfo sleeve

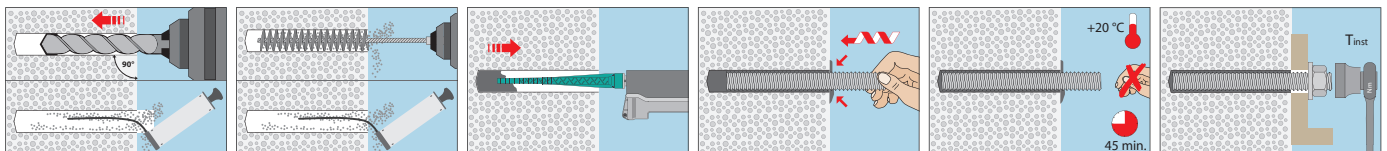

Installation in perforated brick with perfo sleeve

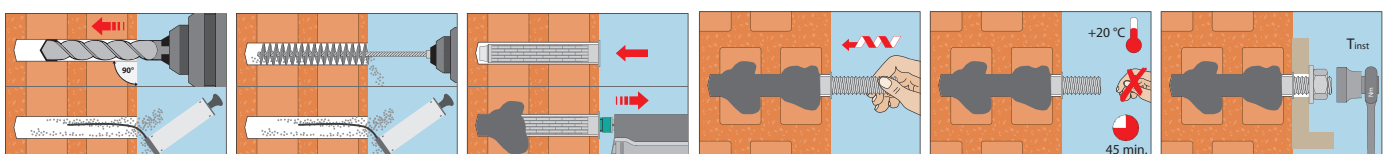



Extract from Permissible Service Conditions of European Technical Assessment ETA-17/0006

Approved loads for single anchor without influence of spacing and edge distance. Butt joint and horizontal joint with adhesive. Range of temperature -40°C to 24°C/40°C¹⁾ – use category dry/dry. Total safety factor as per ETAG 001 included (γ_M and γ_F).

Injection System VM-EA, perforated brick with Perfo Sleeve

Calcium silicate hollow brick KSL-3DF according EN 771-2, Bulk density ρ : 1,4 kg/dm³, Brick size: 240x175x113 mm (e.g. Wemding)

Threaded studs: Steel: \geq FKL 5.8; A4, HCR: \geq FKL 70			M8	M8 / M10		M12/M16	M12	M16		
Perfo sleeves VM-SH			12x80	16x85	16x130 / 16x130/330	20x85	20x130	20x200	20x130	20x200
Anchorage depth	h_{ef}	[mm]	80	85	130	85	130	200	130	200
Spacing = Minimum spacing parallel to the horizontal joint			$S_{cr} = S_{min,II}$	[mm]	240	240	240	240	240	240
Minimum spacing vertical to the horizontal joint			$S_{min,I}$	[mm]	113	113	113	113	113	113
Edge distance = Minimum edge distance			$C_{cr} = C_{min}$	[mm]	100	100	100	120	120	120
Approved tension load for compressive strength	$f_b \geq 8$ N/mm ²	appr. N [kN]	0,4	0,4	0,7	0,4	0,7	0,7	0,7	0,7
	$f_b \geq 12$ N/mm ²	appr. N [kN]	0,6	0,6	1,0	0,6	1,0	1,0	1,0	1,0
	$f_b \geq 14$ N/mm ²	appr. N [kN]	0,7	0,7	1,1	0,7	1,1	1,1	1,1	1,1
Approved shear load for compressive strength	$f_b \geq 8$ N/mm ²	appr. V [kN]	0,6	0,7	0,9	0,9	0,9	0,9	1,1	1,1
	$f_b \geq 12$ N/mm ²	appr. V [kN]	0,7	1,0	1,3	1,0	1,3	1,3	1,4	1,4
	$f_b \geq 14$ N/mm ²	appr. V [kN]	0,9	1,1	1,4	1,3	1,4	1,4	1,7	1,7
Installation torque			$T_{inst,max}$	[Nm]	8	8	8	8	8	8

Calcium silicate hollow brick KSL-12DF according EN 771-2, Bulk density ρ : 1,4 kg/dm³, Brick size: 498x175x238 mm (e.g. Wemding)

Threaded studs: Steel: \geq FKL 5.8; A4, HCR: \geq FKL 70			M8	M8 / M10		M12 / M16	
Perfo sleeves VM-SH			12x80	16x85	16x130 / 16x130/330	20x85	20x130
Anchorage depth	h_{ef}	[mm]	80	85	130	85	130
Spacing = Minimum spacing parallel to the horizontal joint			$S_{cr} = S_{min,II}$	[mm]	498	498	498
Minimum spacing vertical to the horizontal joint			$S_{min,I}$	[mm]	238	238	238
Edge distance = Minimum edge distance			$C_{cr} = C_{min}$	[mm]	100	100	120
Approved tension load for compressive strength	$f_b \geq 10$ N/mm ²	appr. N [kN]	0,1	0,3	1,0	0,3	1,0
	$f_b \geq 12$ N/mm ²	appr. N [kN]	0,1	0,4	1,3	0,4	1,3
	$f_b \geq 16$ N/mm ²	appr. N [kN]	0,1	0,6	1,6	0,6	1,6
Approved shear load for compressive strength	$f_b \geq 10$ N/mm ²	appr. V [kN]	0,9	1,7	2,0	1,7	2,0
	$f_b \geq 12$ N/mm ²	appr. V [kN]	1,0	2,0	2,3	2,0	2,3
	$f_b \geq 16$ N/mm ²	appr. V [kN]	1,1	2,6	2,9	2,4	2,9
Installation torque			$T_{inst,max}$	[Nm]	2	4	4

Clay hollow brick HLZ-16DF according EN 771-1, Bulk density ρ : 0,83 kg/dm³, Brick size: 497x238x240 mm (e.g. Unipor)

Threaded studs: Steel: \geq FKL 5.8; A4, HCR: \geq FKL 70			M8	M8	M8	M10	M10	M12/M16		
Perfo sleeves VM-SH			12x80	16x85	16x130 / 16x130/330	16x85	16x130 / 16x130/330	20x85	20x130	20x200
Anchorage depth	h_{ef}	[mm]	80	85	130	85	130	85	130	200
Spacing = Minimum spacing parallel to the horizontal joint			$S_{cr} = S_{min,II}$	[mm]	497	497	497	497	497	497
Minimum spacing vertical to the horizontal joint			$S_{min,I}$	[mm]	238	238	238	238	238	238
Edge distance = Minimum edge distance			$C_{cr} = C_{min}$	[mm]	100	100	100	100	120	120
Approved tension load for compressive strength	$f_b \geq 6$ N/mm ²	appr. N [kN]	0,3	0,4	0,7	0,4	0,7	0,6	0,7	0,7
	$f_b \geq 9$ N/mm ²	appr. N [kN]	0,3	0,6	0,9	0,6	0,9	0,7	0,9	0,9
	$f_b \geq 12$ N/mm ²	appr. N [kN]	0,4	0,7	1,0	0,7	1,0	1,0	1,0	1,0
	$f_b \geq 14$ N/mm ²	appr. N [kN]	0,4	0,7	1,0	0,7	1,0	1,0	1,0	1,0
Approved shear load for compressive strength	$f_b \geq 6$ N/mm ²	appr. V [kN]	0,7	1,1	1,1	1,1	1,7	1,1	1,7	1,7
	$f_b \geq 9$ N/mm ²	appr. V [kN]	0,9	1,3	1,4	1,4	2,0	1,4	2,0	2,0
	$f_b \geq 12$ N/mm ²	appr. V [kN]	1,0	1,6	1,7	1,7	2,3	1,7	2,3	2,3
	$f_b \geq 14$ N/mm ²	appr. V [kN]	1,1	1,7	1,9	1,7	2,6	1,7	2,6	2,6
Installation torque			$T_{inst,max}$	[Nm]	6	6	6	6	6	6

Clay hollow brick Porotherm Homebric according EN 771-1, Bulk density ρ : 0,68 kg/dm³, Brick size: 500x200x299 mm (e.g. Wienerberger)

Threaded studs: Steel: \geq FKL 5.8; A4, HCR: \geq FKL 70			M8	M8 / M10		M12 / M16	
Perfo sleeves VM-SH			12x80	16x85	16x130 / 16x130/330	20x85	20x130
Anchorage depth	h_{ef}	[mm]	80	85	130	85	130
Spacing = Minimum spacing parallel to the horizontal joint			$S_{cr} = S_{min,II}$	[mm]	500	500	500
Minimum spacing vertical to the horizontal joint			$S_{min,I}$	[mm]	299	299	299
Edge distance = Minimum edge distance			$C_{cr} = C_{min}$	[mm]	100	100	120
Approved tension load for compressive strength	$f_b \geq 6$ N/mm ²	appr. N [kN]	0,3	0,3	0,4	0,3	0,4
	$f_b \geq 8$ N/mm ²	appr. N [kN]	0,3	0,3	0,4	0,3	0,4
	$f_b \geq 10$ N/mm ²	appr. N [kN]	0,3	0,4	0,6	0,4	0,6
Approved shear load for compressive strength	$f_b \geq 6$ N/mm ²	appr. V [kN]	0,6	0,6	0,7	0,9	0,9
	$f_b \geq 8$ N/mm ²	appr. V [kN]	0,7	0,7	0,9	1,0	1,0
	$f_b \geq 10$ N/mm ²	appr. V [kN]	0,9	0,9	1,0	1,1	1,1
Installation torque			$T_{inst,max}$	[Nm]	2	6	6

¹⁾Max. long term temperature / max. short term temperature



Extract from Permissible Service Conditions of European Technical Assessment ETA-17/0006

Approved loads for single anchor without influence of spacing and edge distance. Butt joint and horizontal joint with adhesive.

Range of temperature -40°C to 24°C/40°C¹⁾ – use category dry/dry. Total safety factor as per ETAG 001 included (γ_M and γ_P).

Injection System VM-EA, perforated brick with Perfo Sleeve

Clay hollow brick BGV Thermo according EN 771-1, Bulk density ρ : 0,62 kg/dm³, Brick size: 500x200x314 mm (e.g. Leroux)

Threaded studs: Steel: \geq FKL 5.8; A4, HCR: \geq FKL 70			M8	M8/M10	M8	M10	M12	M16	M12/M16
Perfo sleeves VM-SH			12x80	16x85	16x130 16x130/330	16x130 16x130/330	20x85	20x85	20x130
Anchorage depth	h_{ef}	[mm]	80	85	130	130	85	85	130
Spacing = Minimum spacing parallel to the horizontal joint	$s_{cr} = s_{min,II}$	[mm]	500	500	500	500	500	500	500
Minimum spacing vertical to the horizontal joint	$s_{min,L}$	[mm]	314	314	314	314	314	314	314
Edge distance = Minimum edge distance	$c_{cr} = c_{min}$	[mm]	100	100	100	100	120	120	120
Approved tension load for compressive strength	$f_b \geq 4 \text{ N/mm}^2$	appr. N	[kN]	0,1	0,2	0,3	0,3	0,2	0,3
	$f_b \geq 6 \text{ N/mm}^2$	appr. N	[kN]	0,2	0,3	0,3	0,4	0,3	0,4
	$f_b \geq 10 \text{ N/mm}^2$	appr. N	[kN]	0,3	0,3	0,4	0,4	0,3	0,4
Approved shear load for compressive strength	$f_b \geq 4 \text{ N/mm}^2$	appr. V	[kN]	0,6	0,6	0,7	0,7	0,6	0,7
	$f_b \geq 6 \text{ N/mm}^2$	appr. V	[kN]	0,6	0,7	0,9	0,9	0,9	0,9
	$f_b \geq 10 \text{ N/mm}^2$	appr. V	[kN]	0,9	1,0	1,1	1,1	1,0	1,1
Installation torque	$T_{inst,max}$	[Nm]	2	4	4	4	4	4	4

Clay hollow brick Calibric Th according EN 771-1, Bulk density ρ : 0,62 kg/dm³, Brick size: 500x200x314 mm (e.g. Terreal)

Threaded studs: Steel: \geq FKL 5.8; A4, HCR: \geq FKL 70			M8	M8/M10	M8	M10	M12	M16	M12	M16
Perfo sleeves VM-SH			12x80	16x85	16x130 16x130/330	16x130 16x130/330	20x85	20x85	20x130	20x130
Anchorage depth	h_{ef}	[mm]	80	85	130	130	85	85	130	130
Spacing = Minimum spacing parallel to the horizontal joint	$s_{cr} = s_{min,II}$	[mm]	500	500	500	500	500	500	500	500
Minimum spacing vertical to the horizontal joint	$s_{min,L}$	[mm]	314	314	314	314	314	314	314	314
Edge distance = Minimum edge distance	$c_{cr} = c_{min}$	[mm]	100	100	100	100	120	120	120	120
Approved tension load for compressive strength	$f_b \geq 6 \text{ N/mm}^2$	appr. N	[kN]	0,2	0,2	0,3	0,3	0,2	0,3	0,3
	$f_b \geq 9 \text{ N/mm}^2$	appr. N	[kN]	0,3	0,3	0,3	0,3	0,3	0,4	0,3
	$f_b \geq 12 \text{ N/mm}^2$	appr. N	[kN]	0,3	0,3	0,3	0,4	0,3	0,4	0,4
Approved shear load for compressive strength	$f_b \geq 6 \text{ N/mm}^2$	appr. V	[kN]	0,7	1,0	1,0	1,0	1,7	1,7	1,7
	$f_b \geq 9 \text{ N/mm}^2$	appr. V	[kN]	1,0	1,3	1,3	1,3	2,1	2,1	2,1
	$f_b \geq 12 \text{ N/mm}^2$	appr. V	[kN]	1,1	1,6	1,6	1,6	2,4	2,4	2,4
Installation torque	$T_{inst,max}$	[Nm]	2	2	2	2	2	2	2	2

Clay hollow brick Urbric according EN 771-1, Bulk density ρ : 0,74 kg/dm³, Brick size: 560x200x274 mm (e.g. Imerys)

Threaded studs: Steel: \geq FKL 5.8; A4, HCR: \geq FKL 70			M8	M8 / M10	M12 / M16
Perfo sleeves VM-SH			12x80	16x85	16x130 16x130/330
Anchorage depth	h_{ef}	[mm]	80	85	130
Spacing = Minimum spacing parallel to the horizontal joint	$s_{cr} = s_{min,II}$	[mm]	560	560	560
Minimum spacing vertical to the horizontal joint	$s_{min,L}$	[mm]	274	274	274
Edge distance = Minimum edge distance	$c_{cr} = c_{min}$	[mm]	100	100	100
Approved tension load for compressive strength	$f_b \geq 6 \text{ N/mm}^2$	appr. N	[kN]	0,3	0,3
	$f_b \geq 9 \text{ N/mm}^2$	appr. N	[kN]	0,3	0,4
	$f_b \geq 12 \text{ N/mm}^2$	appr. N	[kN]	0,3	0,6
Approved shear load for compressive strength	$f_b \geq 6 \text{ N/mm}^2$	appr. V	[kN]	0,9	1,0
	$f_b \geq 9 \text{ N/mm}^2$	appr. V	[kN]	1,0	1,3
	$f_b \geq 12 \text{ N/mm}^2$	appr. V	[kN]	1,0	1,4
Installation torque	$T_{inst,max}$	[Nm]	2	2	2

Clay hollow brick Blocchi Leggeri according EN 771-1, Bulk density ρ : 0,55 kg/dm³, Brick size: 250x120x250 mm (e.g. Wienerberger)

Threaded studs: Steel: \geq FKL 5.8; A4, HCR: \geq FKL 70			M8	M8 / M10	M12 / M16
Perfo sleeves VM-SH			12x80	16x85	16x130 16x130/330
Anchorage depth	h_{ef}	[mm]	80	85	130
Spacing = Minimum spacing parallel to the horizontal joint	$s_{cr} = s_{min,II}$	[mm]	250	250	250
Minimum spacing vertical to the horizontal joint	$s_{min,L}$	[mm]	250	250	250
Edge distance = Minimum edge distance	$c_{cr} = c_{min}$	[mm]	100	100	100
Approved tension load for compressive strength	$f_b \geq 4 \text{ N/mm}^2$	appr. N	[kN]	0,1	0,1
	$f_b \geq 6 \text{ N/mm}^2$	appr. N	[kN]	0,1	0,2
	$f_b \geq 8 \text{ N/mm}^2$	appr. N	[kN]	0,2	0,2
Approved shear load for compressive strength	$f_b \geq 4 \text{ N/mm}^2$	appr. V	[kN]	0,6	0,6
	$f_b \geq 6 \text{ N/mm}^2$	appr. V	[kN]	0,6	0,6
	$f_b \geq 8 \text{ N/mm}^2$	appr. V	[kN]	0,7	0,7
Installation torque	$T_{inst,max}$	[Nm]	4	4	4

¹⁾Max. long term temperature / max. short term temperature

Extract from Permissible Service Conditions of ETA-17/0006

Approved loads for single anchor without influence of spacing and edge distance. Butt joint and horizontal joint with adhesive.
Range of temperature -40°C to $24^{\circ}\text{C}/40^{\circ}\text{C}^{1)}$ – use category dry/dry. Total safety factor as per ETAG 001 included (γ_{M} and γ_{P}).

Injection System VM-EA, perforated brick with Perfo Sleeve
Clay hollow brick Doppio Uni according EN 771-1, Bulk density ρ : 0,92 kg/dm³, Brick size: 250x120x120 mm (e.g. Wienerberger)

Threaded studs: Steel: \geq FKL 5.8; A4, HCR: \geq FKL 70			M8	M8 / M10		M12 / M16	
Perfo sleeves VM-SH			12x80	16x85	16x130 16x130/330	20x85	20x130 20x200
Anchorage depth	h_{ef}	[mm]	80	85	130	85	130 200
Spacing = Minimum spacing parallel to the horizontal joint	$s_{cr} = s_{min,II}$	[mm]	250	250	250	250	250
Minimum spacing vertical to the horizontal joint	$s_{min,I}$	[mm]	120	120	120	120	120
Edge distance = Minimum edge distance	$c_{cr} = c_{min}$	[mm]	100	100	100	120	120 120
Approved tension load for compressive strength	$f_b \geq 10 \text{ N/mm}^2$	appr. N	0,3	0,3	0,3	0,3	0,3 0,3
	$f_b \geq 16 \text{ N/mm}^2$	appr. N	0,3	0,3	0,3	0,4	0,4 0,4
	$f_b \geq 20 \text{ N/mm}^2$	appr. N	0,3	0,3	0,4	0,4	0,4 0,4
	$f_b \geq 28 \text{ N/mm}^2$	appr. N	0,4	0,4	0,4	0,6	0,6 0,6
Approved shear load for compressive strength	$f_b \geq 10 \text{ N/mm}^2$	appr. V	0,6	0,6	0,6	0,6	0,6 0,6
	$f_b \geq 16 \text{ N/mm}^2$	appr. V	0,7	0,7	0,7	0,7	0,7 0,7
	$f_b \geq 20 \text{ N/mm}^2$	appr. V	0,9	0,9	0,9	0,9	0,9 0,9
	$f_b \geq 28 \text{ N/mm}^2$	appr. V	1,0	1,0	1,0	1,0	1,0 1,0
Installation torque	$T_{inst,max}$	[Nm]	4	4	4	4	4 4

Brickwork of hollow lightweight concrete Bloc creux B40 according EN 771-3, Bulk density ρ : 0,8 kg/dm³, Brick size: 494x200x190 mm (e.g. Sepa)

Threaded studs: Steel: \geq FKL 5.8; A4, HCR: \geq FKL 70			M8	M8 / M10		M12 / M16	
Perfo sleeves VM-SH			12x80	16x85	16x130 16x130/330	20x85	20x130
Anchorage depth	h_{ef}	[mm]	80	85	130	85	130
Spacing = Minimum spacing parallel to the horizontal joint	$s_{cr} = s_{min,II}$	[mm]	494	494	494	494	494
Minimum spacing vertical to the horizontal joint	$s_{min,I}$	[mm]	190	190	190	190	190
Edge distance = Minimum edge distance	$c_{cr} = c_{min}$	[mm]	100	100	100	120	120
Approved tension load for compressive strength	$f_b \geq 4 \text{ N/mm}^2$	appr. N	0,1	0,2	0,6	0,3	0,6
Approved shear load for compressive strength	$f_b \geq 4 \text{ N/mm}^2$	appr. V	0,3	0,9	1,0	0,9	1,0
Installation torque	$T_{inst,max}$	[Nm]	2	2	2	2	2

Brickwork of hollow lightweight concrete Leca Lex harkko RUH-200 according EN 771-3, Bulk density ρ : 0,7 kg/dm³, Brick size: 498x200x195 mm (e.g. Saint-Gobain Weber)

Threaded studs: Steel: \geq FKL 5.8; A4, HCR: \geq FKL 70			M8	M8 / M10		M12 / M16	
Perfo sleeves VM-SH			12x80	16x85	16x130 16x130/330	20x85	20x130
Anchorage depth	h_{ef}	[mm]	80	85	130	85	130
Spacing = Minimum spacing parallel to the horizontal joint	$s_{cr} = s_{min,II}$	[mm]	498	498	498	498	498
Minimum spacing vertical to the horizontal joint	$s_{min,I}$	[mm]	195	195	195	195	195
Edge distance = Minimum edge distance	$c_{cr} = c_{min}$	[mm]	120	127	195	127	195
Approved tension load for compressive strength	$f_b \geq 2,7 \text{ N/mm}^2$	appr. N	0,6	0,6	0,7	0,7	0,7
Approved shear load for compressive strength	$f_b \geq 2,7 \text{ N/mm}^2$	appr. V	0,7	1,0	1,0	1,0	1,0
Installation torque	$T_{inst,max}$	[Nm]	8	8	8	8	8

Installation parameters in perforated bricks with perfo sleeve

Threaded studs: Steel: \geq FKL 5.8; A4, HCR: \geq FKL 70			M8	M8 / M10		M12 / M16	
Perfo sleeves VM-SH			12x80	16x85	16x130 16x130/330	20x85	20x130 20x200
Diameter of drill hole	d_o	[mm]	12	16	16	20	20 20
Drill hole depth	h_o	[mm]	85	90	135	90	135 205
Drilling method					Rotary drilling		
Minimum wall thickness	h_{min}	[mm]	115	115	175	175	115 175 240
Clearance hole in the fixture	$d_{f \leq}$	[mm]	9	9 / 12	9 / 12	9 / 12	14 / 18 14 / 18 14 / 18
Diameter of brush	$d_b \geq$	[mm]	14	18	18	18	22 22 22
Installation torque	$T_{inst,max}$	[Nm]			s. brick information		
Amount of adhesive per drill hole		[ml]	11,2	24,9	38,0	38 - 68 ²⁾	41,1 62,9 96,7
Drill holes per cartridge	VM-EA 300	[Pcs.]	23	10	6	3 - 6 ²⁾	6 4 2
	VM-EA 345	[Pcs.]	27	12	8	4 - 8 ²⁾	7 4 3
	VM-EA 420	[Pcs.]	33	15	10	5 - 10 ²⁾	9 6 3

¹⁾Max. long term temperature / max. short term temperature

²⁾Dependent on actual perfo sleeve length

Injection System VME

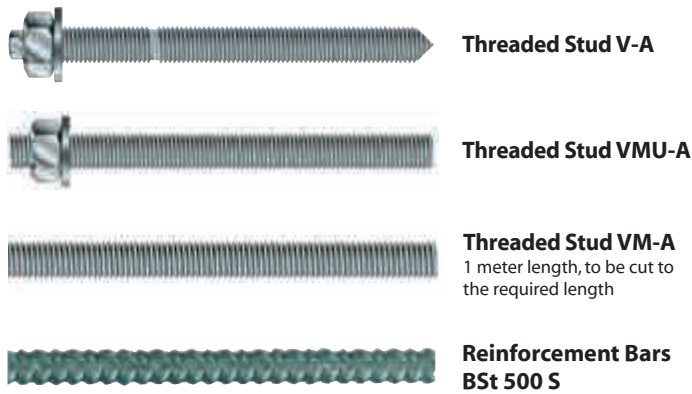

Cartridge VME 385
Side-by-side cartridge
Content: 385ml
With big mixer VM-XL and reducers / extension tube for drill holes from 12mm diameter

Cartridge VME 585
Side-by-side cartridge
Content: 585ml
With big mixer VM-XL and reducers / extension tube for drill holes from 12mm diameter

Cartridge VME 1400
Side-by-side cartridge
Content: 1400ml
With big mixer VM-XL and reducers / extension tube for drill holes from 12mm diameter

Range of loading: 3,1 - 128 kN

Concrete quality: C20/25 - C50/60

Material: Steel zinc plated, hot dip galvanized, Stainless steel A4/316, Stainless steel HCR, BSt 500 S

Description

The Injection System VME is an approved system for fixings of threaded studs or reinforcement bars in cracked and non-cracked concrete. In the cartridge, the epoxy resin and the hardener are separated. By means of the dispenser gun VM-P the components are pushed through the mixer nozzle, activated and injected into the drill hole. The Injection System VME can be used with the threaded Studs V-A, VMU-A and also the internally threaded sleeves VMU-IG. It can also be used with VM-A studs, sold by meter to be cut to the required length or with standard reinforcement bars.



Applications

Fixing of rack systems, railings, steel structures, noise barriers, stairs and machines.

Subsequent closure of wall and ceiling openings, reinforcement of existing concrete structures, installation of reinforcement for the connection of the following concrete components (if the installation of reinforcement was missed or not possible because of the working process), connection of steel structures.

Advantages:

- approved in cracked and non-cracked concrete
- approved with threaded studs, internally threaded sleeves and reinforcement bars
- approved with standard threaded studs (test certificate required)
- approved to use under seismic action according to the performance category C1 and C2 (M12-M16)
- also approved for post-installed rebar connections according to ETA-07/0299 / Z-21.8-1872
- approved for diamond coring (ETA-13/0773) in non-cracked concrete
- ICC Evaluation Service listing for cracked and non-cracked concrete
- variable anchorage depth for less drilling efforts
- long curing times for an economic working process with serial installations and/or large drill holes
- suitable for dry and wet concrete and in water-filled drill holes
- styrene-free
- fire test report

Injection Cartridge VME



- Very high loads
- No shrinkage

Description	Ref. No.	Content ml	Content of master box pcs	Weight per master box kg	Weight per piece kg
Cartridge VME 385	28255501	385	12	8,5	0,70
Cartridge VME 585	28255601	585	12	12,09	0,98
Cartridge VME 1400	28255701	1400	5	12,34	2,40
Static mixer VM-XL ¹⁾	28305201	-	10	0,28	0,03
Static mixer VM-X ²⁾	28305111	-	12	0,12	0,01

One static mixer VM-XL as well as one screw-on cap comes with each cartridge.

¹⁾ Mixer VM-XL comes with a reducers / extension tube. Suitable for drill holes from 12mm diameter.

²⁾ Static mixer VM-X only required for drill hole diameter of 10mm (special accessories).

Threaded studs for use in **cracked and non-cracked concrete**

Threaded Stud VMU-A

Steel, zinc plated 5.8
Dimensions see page 107



- For use in structures subject to dry internal conditions
- Steel, zinc plated 8.8 on demand

Threaded Stud VMU-A A4

Stainless steel A4
Dimensions see page 107



- For use in structures subject to dry internal conditions or external atmospheric exposure
- Stainless steel HCR on demand

Internally Threaded Sleeve VMU-IG

Steel, zinc plated 5.8
Dimensions see page 108



- For use in structures subject to dry internal conditions
- With internal thread

Internally Threaded Sleeve VMU-IG A4

Stainless steel A4
Dimensions see page 108

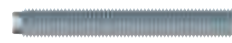

- For use in structures subject to dry internal conditions or external atmospheric exposure
- With internal thread

Threaded Stud V-A

Steel, zinc plated 5.8
Dimensions see page 144



- For use in structures subject to dry internal conditions
- Steel, zinc plated 8.8 on demand

Threaded Stud V-A A4

Stainless steel A4
Dimensions see page 144



- For use in structures subject to dry internal conditions or external atmospheric exposure

Threaded Stud V-A fvz

Steel, hot dip galvanized 5.8
Dimensions see page 144



- For use in structures subject to dry internal conditions
- Steel hot dip galvanized 8.8 on demand

Threaded Stud V-A HCR

Stainless steel HCR
Dimensions see page 144



- For use in particularly corrosive environments
- High corrosion resistant steel 1.4529 (HCR)

Threaded stud VM-A

Steel 5.8, zinc plated
Dimensions see page 108



- For use in structures subject to dry internal conditions
- Threaded studs, of 1 meter length, to be cut to the required length
- Comes with manufacturer's certificate (3.1 EN 10204) in every package

Threaded stud VM-A

Stainless steel A4
Dimensions see page 108



- For use in structures subject to dry internal conditions or external atmospheric exposure
- Threaded studs, of 1 meter length, to be cut to the required length
- Comes with manufacturer's certificate (3.1 EN 10204) in every package

Threaded stud VM-A

Steel 8.8, zinc plated
Dimensions see page 108



- For use in structures subject to dry internal conditions
- Threaded studs, of 1 meter length, to be cut to the required length
- Comes with manufacturer's certificate (3.1 EN 10204) in every package

Installation

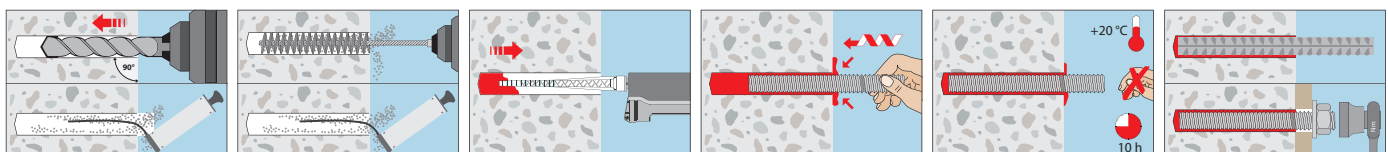

Injecting equipment

Retaining Washer



- For bubble-free filling of the drill hole
- Only for horizontal or overhead installation for drill hole diameter of 24 mm and bigger.
- Fits to extension tubes VM-XE 10 and VM-XLE 16

Description	Ref. No.	Colour	Suitable for drill hole Ø mm	To use in conjunction with	Package content pcs	Weight per pkg. kg
VM-IA 24	85924101	black	24	VM-XL + VM-XE / VM-XLE	20	0,06
VM-IA 25	85925201	black	25	VM-XL + VM-XE / VM-XLE	20	0,06
VM-IA 28	85928101	black	28	VM-XL + VM-XE / VM-XLE	20	0,08
VM-IA 32	85932201	black	32	VM-XL + VM-XE / VM-XLE	20	0,08
VM-IA 35	85935201	black	35	VM-XL + VM-XE / VM-XLE	20	0,08
VM-IA 40	85938201	black	40	VM-XL + VM-XE / VM-XLE	20	0,08

Extension Tubes

Description	Ref. No.	Length mm	Diameters mm	To use in conjunction with	Pkg. cont. pcs.	Weight per pkg. kg
VM-XE 10/200	28306011	200	10	VM-XL, VM-X	12	0,12
VM-XE 10/500	85951101	500	10	VM-XL, VM-X	10	0,20
VM-XE 10/1000	85952101	1000	10	VM-XL, VM-X	10	0,30

Drill hole Cleaning

Cleaning Brush RB M6



- With connection thread M6
- Extension for large depths of drill hole
- For drilling machines with keyed chuck
- Separate SDS plus adaptor with internal thread M6 for SDS plus drill holder

Description	Ref. No.	Suitable for drill hole Ø mm	Total length of brush mm	Suitable for Threaded stud	Reinforcement Bars	Pkg. cont. pcs.	Weight per piece kg
RB 10 M6	33510101	10	130	M8	-	1	0,05
RB 12 M6	33512101	12	140	M10	Ø8	1	0,05
RB 14 M6	33514101	14	180	M12	Ø10	1	0,05
RB 16 M6	33516101	16	200	-	Ø12	1	0,05
RB 18 M6	33518101	18	200	M16	Ø14	1	0,05
RB 20 M6	33520101	20	220	-	Ø16	1	0,05
RB 24 M6	33524101	24	250	M20	Ø20	1	0,06
RB 28 M6	33528101	28	260	M24	-	1	0,06
RB 32 M6	33532101	32	350	M27	Ø25	1	0,08
RB 35 M6	33535101	35	350	M30	Ø28	1	0,08
RB 40 M6	33537101	40	350	-	Ø32	1	0,08
RBL M6	33968101	Brush extension 150mm with connection thread M6				1	0,09
RBL M6 SDS	33350101	SDS Plus adapter with internal thread M6				1	0,06

Blow-out pump VM-AP



- For approval-compliant air-cleaning of drill holes in non-cracked concrete with a diameter up to 20 mm and a drill hole depth at most ten times larger than the diameter of the threaded stud (VME)
- For best drill hole cleaning, the hose must reach the bottom of the drill hole

Description	Ref. No.	Hose Ø mm	For drill hole Ø mm	Max. drill hole depth ²⁾ mm	Pkg. cont. pcs	Weight per piece kg
Blow-out pump VM-AP 360	33200101	8	8 ¹⁾ -20	330	1	0,27

¹⁾With extension tube Ø 6 x 100mm

²⁾For through fastening: Maximum drill hole depth through fixture

Air gun VM-ABP



- For approval-compliant drill hole cleaning with compressed air for drill holes with a diameter larger than 6 mm
- For best drill hole cleaning, the nozzle of the air gun must reach the bottom of the drill hole

Description	Ref. No.	Nozzle-Ø mm	For drill hole Ø mm	Max. drill hole depth ¹⁾ mm	Pkg. cont. pcs.	Weight per piece kg
VM-ABP 200	33090101	5	6-20	240	1	0,55
VM-ABP 250	33100101	16	18-40	240	1	1,00
VM-ABP 500	33106101	16	18-40	480	1	1,30

¹⁾For through fastening: Maximum drill hole depth through fixture

Dispenser VM-P Standard



→ For occasional use, metal version

→ Piston rod with adjusting screw

Description	Ref. No.	Suitable for cartridge	Pkg. cont. pcs.	Weight per piece kg
VM-P 385 Standard	28353010	385ml	1	1,33

Dispenser VM-P 385 Profi



→ Professional dispenser with an ideal center of gravity for more comfortable working

→ Automatic pressure release for minimum adhesive overrun

Description	Ref. No.	Suitable for cartridge	Pkg. cont. pcs.	Weight per piece kg
VM-P 385 Profi	28353015	385ml	1	1,20

Dispenser VM-P 585 Profi



→ Professional dispenser with an ideal center of gravity for more comfortable working

→ Combi-tool for many different types of cartridges

→ Automatic pressure release for minimum adhesive overrun

Description	Ref. No.	Suitable for cartridge	Pkg. cont. pcs.	Weight per piece kg
VM-P 585 Profi	28353201	280ml, 300ml, 330ml, 380ml, 385ml, 410ml, 420ml, 585ml	1	1,67

Dispenser VM-P Pneumatic



VM-P 1400 Pneumatik

→ Professional air tool with an optimum center of gravity and quick cartridge exchange

→ Automatic pressure release system reduces adhesive overrun to a minimum

→ Single-hand pressure regulation to adjust the piston speed

→ With compressed air connection nipple

Description	Ref. No.	Suitable for cartridge	max. working pressure 8bar, 40l/min	Pkg. cont. pcs.	Weight per piece kg
VM-P 585 Pneumatic	28352101	385ml, 585ml	1	3,60	
VM-P 1400 Pneumatic	28352201	1400ml	1	6,40	

Dispenser VM-P Akku



→ Professional, solid battery cartridge dispenser in a plastic case

→ Repeat function, for retrieving the last fill quantity

→ Stepless variable pressing speed

→ Overrun-quantity-stop by automatic return after release of the dispensing switch

Description	Ref. No.	Suitable for cartridge	Press-out force kN	Weight ¹⁾ kg	Dimensions ¹⁾ L x B x H mm	Pkg. cont. pcs.	Weight per piece kg
VM-P 585 Akku	28353301	385ml, 585ml	5,0	3,86	440 x 180 x 285	1	8,05
Accessories (for all models)							
Replacement battery	28352411			18 V/2,0 Ah		1	1,00
Shoulder strap	28359991			adjustable		1	0,02



Extract from Permissible Service Conditions of ETA-09/0350.

Approved loads for single anchor without influence of spacing and edge distance in dry or wet concrete for temperature range I to -40°C to +24°C/+40°C¹⁾ and for temperature range III -40°C to +43°C/+72°C (For temperature range II -40°C to +43°C/60°C and loads for threaded studs 4.6/4.8/5.6/ see ETA-09/350). Total safety factor as per ETAG 001 included (γ_M and γ_P). Load capacities under fire exposure see page 168.

Loads and performance data

Injection System VME, threaded stud steel grade 5.8				M8	M10	M12	M16	M20	M24	M27	M30	
Range of anchorage depths	$h_{ef,min} - h_{ef,max}$	[mm]		60 - 96	60 - 120	70 - 144	80 - 192	90 - 240	96 - 288	108 - 324	120 - 360	
Approved loads, tension for $h_{ef,min} - h_{ef,max}$ cracked concrete												
Range of temperature	24°C/40°C ¹⁾	C20/25	appr. N	[kN]	4,2-6,7	5,2-10,5	7,9-16,2	10,2-24,9	10,5-30,8	11,5-40,6	13,7-51,4	16,1-63,5
	43°C/72°C ¹⁾	C20/25	appr. N	[kN]	2,4-3,8	3,0-6,0	4,2-8,6	5,6-13,4	5,8-15,4	7,4-22,2	9,3-28,0	11,5-34,6
non-cracked concrete												
Range of temperature	24°C/40°C ¹⁾	C20/25	appr. N	[kN]	8,6	9,3-13,8	11,7-20,0	14,3-37,1	14,7-58,1	16,2-83,8	19,3-100,2	22,6-117,3
	43°C/72°C ¹⁾	C20/25	appr. N	[kN]	5,1-8,1	6,4-12,7	8,4-17,2	12,0-28,7	13,5-35,9	16,2-51,7	19,3-60,8	22,6-75,0
Approved loads, shear for $h_{ef,min} - h_{ef,max}$ cracked concrete												
Range of temperature	24°C/40°C ¹⁾	C20/25	appr. V	[kN]	5,1	8,6	12,0	22,3	29,3-34,9	32,3-50,3	38,5-65,7	45,1-80,0
	43°C/72°C ¹⁾	C20/25	appr. V	[kN]	5,1	7,2-8,6	10,1-12,0	13,4-22,3	16,2-34,9	20,7-50,3	26,2-65,7	32,3-80,0
non-cracked concrete												
Range of temperature	24°C/40°C ¹⁾	C20/25	appr. V	[kN]	5,1	8,6	12,0	22,3	34,9	45,2-50,3	54,0-65,7	63,2-80,0
	43°C/72°C ¹⁾	C20/25	appr. V	[kN]	5,1	8,6	12,0	22,3	34,9	45,2-50,3	54,0-65,7	63,2-80,0

Injection System VME, threaded stud steel grade 8.8				M8	M10	M12	M16	M20	M24	M27	M30	
Range of anchorage depths	$h_{ef,min} - h_{ef,max}$	[mm]		60 - 96	60 - 120	70 - 144	80 - 192	90 - 240	96 - 288	108 - 324	120 - 360	
Approved loads, tension for $h_{ef,min} - h_{ef,max}$ cracked concrete												
Range of temperature	24°C/40°C ¹⁾	C20/25	appr. N	[kN]	4,2-6,7	5,2-10,5	7,9-16,2	10,2-24,9	10,5-30,8	11,5-40,6	13,7-51,4	16,1-63,5
	43°C/72°C ¹⁾	C20/25	appr. N	[kN]	2,4-3,8	3,0-6,0	4,2-8,6	5,6-13,4	5,8-15,4	7,4-22,2	9,3-28,0	11,5-34,6
non-cracked concrete												
Range of temperature	24°C/40°C ¹⁾	C20/25	appr. N	[kN]	9,0-13,8	9,3-21,9	11,7-31,9	14,3-53,3	14,7-63,9	16,2-84,0	19,3-100,2	22,6-117,3
	43°C/72°C ¹⁾	C20/25	appr. N	[kN]	5,1-8,1	6,4-12,7	8,4-17,2	12-28,7	13,5-35,9	16,2-51,7	19,3-60,8	22,6-75,0
Approved loads, shear for $h_{ef,min} - h_{ef,max}$ cracked concrete												
Range of temperature	24°C/40°C ¹⁾	C20/25	appr. V	[kN]	8,6	12,6-13,1	18,8-19,4	24,5-36,0	29,3-56,0	32,3-80,6	38,5-105,1	45,1-128,0
	43°C/72°C ¹⁾	C20/25	appr. V	[kN]	5,7-8,6	7,2-13,1	10,1-19,4	13,4-32,2	16,2-43,1	20,7-62,0	26,2-78,5	32,3-96,9
non-cracked concrete												
Range of temperature	24°C/40°C ¹⁾	C20/25	appr. V	[kN]	8,6	13,1	19,4	34,4-36,0	41,1-56,0	45,2-80,6	54,0-105,1	63,2-128,0
	43°C/72°C ¹⁾	C20/25	appr. V	[kN]	8,6	13,1	19,4	28,7-36,0	37,7-56,0	45,2-80,6	54,0-105,1	63,2-128,0

Injection System VME, threaded stud ss A4/316 / ss HCR				M8	M10	M12	M16	M20	M24	M27	M30	
Range of anchorage depths	$h_{ef,min} - h_{ef,max}$	[mm]		60 - 96	60 - 120	70 - 144	80 - 192	90 - 240	96 - 288	108 - 324	120 - 360	
Approved loads, tension for $h_{ef,min} - h_{ef,max}$ cracked concrete												
Range of temperature	24°C/40°C ¹⁾	C20/25	appr. N	[kN]	4,2-6,7	5,2-10,5	7,9-16,2	10,2-24,9	10,5-30,8	11,5-40,6	13,7-51,4	16,1-63,5
	43°C/72°C ¹⁾	C20/25	appr. N	[kN]	2,4-3,8	3,0-6,0	4,2-8,6	5,6-13,4	5,8-15,4	7,4-22,2	9,3-28,0	11,5-34,6
non-cracked concrete												
Range of temperature	24°C/40°C ¹⁾	C20/25	appr. N	[kN]	9,0-9,9	9,3-15,7	11,7-22,5	14,3-42,0	14,7-63,9	16,2-84,0	19,3-57,4	22,6-70,2
	43°C/72°C ¹⁾	C20/25	appr. N	[kN]	5,1-8,1	6,4-12,7	8,4-17,2	12,0-28,7	13,5-35,9	16,2-51,7	19,3-57,4	22,6-70,2
Approved loads, shear for $h_{ef,min} - h_{ef,max}$ cracked concrete												
Range of temperature	24°C/40°C ¹⁾	C20/25	appr. V	[kN]	6,0	9,2	13,7	24,5-25,2	29,3-39,4	32,2-56,8	34,5	42,0
	43°C/72°C ¹⁾	C20/25	appr. V	[kN]	5,7-6,0	7,2-9,2	10,1-13,7	13,4-25,2	16,2-39,4	20,7-56,8	26,2-34,5	32,3-42,0
non-cracked concrete												
Range of temperature	24°C/40°C ¹⁾	C20/25	appr. V	[kN]	6,0	9,2	13,7	25,2	39,4	45,2-56,8	34,5	42,0
	43°C/72°C ¹⁾	C20/25	appr. V	[kN]	6,0	9,2	13,7	25,2	37,7-39,4	45,2-56,8	34,5	42,0

Spacing and edge distance

Min. thickness of concrete slab for $h_{ef,min} - h_{ef,max}$	h_{min}	[mm]	100-126	100-150	100-174	116-228	138-288	152-344	172-388	190-430
Minimum spacing	s_{min}	[mm]	40	50	60	80	100	120	135	150
Minimum edge distance	c_{min}	[mm]	40	50	60	80	100	120	135	150

Installation parameters

Drill hole diameter	d_o	[mm]	10	12	14	18	24	28	32	35
Clearance hole in the fixture	d_f	[mm]	9	12	14	18	22	26	30	33
Range of drill hole depth for $h_{ef,min} - h_{ef,max}$	h_o	[mm]	60 - 96	60 - 120	70 - 144	80 - 192	90 - 240	96 - 288	108 - 324	120 - 360
Installation torque	$\leq T_{inst}$	[Nm]	10	20	40	80	120	160	180	200

¹⁾ Max long term temperature / max short term temperature
Higher concrete strength may lead to higher approved loads.

For anchor designing an easy to operate CD-ROM is available on request or can be downloaded at www.mkt.de.

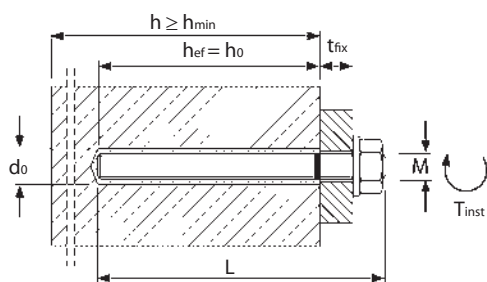

Curing time Injection Adhesive VME

→ Cartridge temperature when installing min. +5°C - +40°C

Temperature (°C) of the base material	maximum working time	minimum curing time	
		dry base material	wet base material
+5°C to +9°C	120 min	50 h	100 h
+10°C to +19°C	90 min	30 h	60 h
+20°C to +29°C	30 min	10 h	20 h
+30°C to +39°C	20 min	6 h	12 h
40°C	12 min	4 h	8 h



Extract from Permissible Service Conditions of ETA-09/0350.

Approved loads for single anchor without influence of spacing and edge distance in dry or wet concrete for temperature range I to -40°C to +24°C/+40°C¹⁾ and for temperature range III -40°C to +43°C/+72°C¹⁾ (For temperature range II -40°C to +43°C/60°C¹⁾ see ETA-09/350). Total safety factor as per ETAG 001 included (γ_M and γ_F).

Loads and performance data				IG M6 x 80	IG M6 x 90	IG M8 x 80	IG M8 x 100	IG M10 x 80	IG M10 x 100	IG M12 x 125	IG M6 x 170	IG M20 x 200
Internally threaded sleeves												
Effective anchorage depth h_{ef}		[mm]		80	90	80	100	80	100	125	170	200
Injection System VME, Internally threaded sleeve VMU-IG, Steel 5.8												
Approved loads, tension for h_{ef}				cracked concrete								
Temperature range	24°C/40°C ¹⁾	C20/25	appr. N [kN]	4,8	4,8	8,6	8,6	10,2	13,0	16,0	24,0	34,6
	43°C/72°C ¹⁾	C20/25	appr. N [kN]	4,0	4,5	4,8	6,0	5,6	7,0	8,0	13,1	19,2
Approved loads, tension for h_{ef}				non-cracked concrete								
Temperature range	24°C/40°C ¹⁾	C20/25	appr. N [kN]	4,8	4,8	8,6	8,6	13,8	13,8	20,0	37,6	48,6
	43°C/72°C ¹⁾	C20/25	appr. N [kN]	4,8	4,8	8,6	8,6	12,0	13,8	18,7	30,5	41,7
Approved loads, tension for h_{ef}				cracked concrete								
Temperature range	24°C/40°C ¹⁾	C20/25	appr. V [kN]	2,9	2,9	5,1	5,1	8,6	8,6	12,0	22,3	34,9
	43°C/72°C ¹⁾	C20/25	appr. V [kN]	2,9	2,9	5,1	5,1	8,6	8,6	12,0	22,3	34,9
Approved loads, tension for h_{ef}				non-cracked concrete								
Temperature range	24°C/40°C ¹⁾	C20/25	appr. V [kN]	2,9	2,9	5,1	5,1	8,6	8,6	12,0	22,3	34,9
	43°C/72°C ¹⁾	C20/25	appr. V [kN]	2,9	2,9	5,1	5,1	8,6	8,6	12,0	22,3	34,9
Injection System VME, Internally threaded sleeve VMU-IG, Stainless steel A4,												
Approved loads, tension for h_{ef}				cracked concrete								
Temperature range	24°C/40°C ¹⁾	C20/25	appr. N [kN]	5,3	5,3	9,0	9,9	10,2	13,0	16,0	24,0	31,0
	43°C/72°C ¹⁾	C20/25	appr. N [kN]	4,0	4,5	4,8	6,0	5,6	7,0	8,0	13,1	19,2
Approved loads, tension for h_{ef}				non-cracked concrete								
Temperature range	24°C/40°C ¹⁾	C20/25	appr. N [kN]	5,3	5,3	9,9	9,9	14,3	15,7	22,5	38,1	31,0
	43°C/72°C ¹⁾	C20/25	appr. N [kN]	5,3	5,3	9,6	9,9	12,0	15,0	18,7	30,5	31,0
Approved loads, tension for h_{ef}				cracked concrete								
Temperature range	24°C/40°C ¹⁾	C20/25	appr. V [kN]	3,2	3,2	6,0	6,0	9,2	9,2	13,7	25,2	18,6
	43°C/72°C ¹⁾	C20/25	appr. V [kN]	3,2	3,2	6,0	6,0	9,2	9,2	13,7	25,2	18,6
Approved loads, tension for h_{ef}				non-cracked concrete								
Temperature range	24°C/40°C ¹⁾	C20/25	appr. V [kN]	3,2	3,2	6,0	6,0	9,2	9,2	13,7	25,2	18,6
	43°C/72°C ¹⁾	C20/25	appr. V [kN]	3,2	3,2	6,0	6,0	9,2	9,2	13,7	25,2	18,6
Spacing and edge distance												
Minimum thickness of concrete slab for h_{ef}	h_{min}	[mm]		110	120	110	130	116	136	169	226	270
Minimum spacing	s_{min}	[mm]		50	50	60	60	80	80	100	120	150
Minimum edge distance	c_{min}	[mm]		50	50	60	60	80	80	100	120	150
Installation parameters												
Diameter of drill hole	d_o	[mm]		12	12	14	14	18	18	22	28	35
Clearance hole in the fixture	$d_f \leq$	[mm]		7	7	9	9	12	12	14	18	22
Range of drill hole depth for h_{ef}	h_o	[mm]		80	90	80	100	80	100	125	170	200
Installation torque	$T_{inst} \leq$	[Nm]		10	10	10	10	20	20	40	60	100
Amount of adhesive per drill hole		[ml]		6,6	7,4	7,9	9,9	10,9	13,6	22,4	54,9	97,4
Injection System VME, reinforcement bars B 500 B				Ø8	Ø10	Ø12	Ø14	Ø16	Ø20	Ø25	Ø28	Ø32
Range of anchorage depths	$h_{ef,min} - h_{ef,max}$	[mm]		60 - 96	60 - 120	70 - 144	75 - 168	80 - 192	90 - 240	100 - 300	112 - 336	128 - 384
Approved loads, tension for $h_{ef,min} - h_{ef,max}$				cracked concrete								
Range of temperature	24°C/40°C ¹⁾	C20/25	appr. N [kN]	4,2-6,7	5,2-10,5	7,9-16,2	9,2-20,5	10,2-24,9	10,5-30,8	12,2-44,1	14,5-55,3	17,7-72,2
	43°C/72°C ¹⁾	C20/25	appr. N [kN]	2,4-3,8	3,0-6,0	4,2-8,6	4,6-10,3	5,6-13,4	5,8-15,4	8,0-24,0	10,1-30,2	13,1-39,4
Approved loads, tension for $h_{ef,min} - h_{ef,max}$				non-cracked concrete								
Range of temperature	24°C/40°C ¹⁾	C20/25	appr. N [kN]	8,4-13,4	9,3-20,9	11,7-28,0	13,0-38,1	14,3-46,0	14,7-61,5	17,2-88,2	20,4-105,8	24,9-129,3
	43°C/72°C ¹⁾	C20/25	appr. N [kN]	4,5-7,2	5,6-11,2	7,9-16,2	9,2-20,5	11,2-26,8	12,5-33,3	16,0-48,1	20,1-60,3	24,9-78,8
Approved loads, shear for $h_{ef,min} - h_{ef,max}$				cracked concrete								
Range of temperature	24°C/40°C ¹⁾	C20/25	appr. V [kN]	6,5	10,1	14,5	19,8	24,5-25,9	29,3-40,4	34,3-63,1	40,6-79,2	49,7-103,4
	43°C/72°C ¹⁾	C20/25	appr. V [kN]	5,7-6,5	7,2-10,1	10,1-14,5	11,0-19,8	13,4-25,9	16,2-40,4	22,4-63,1	28,1-79,2	36,8-103,4
Approved loads, shear for $h_{ef,min} - h_{ef,max}$				non-cracked concrete								
Range of temperature	24°C/40°C ¹⁾	C20/25	appr. V [kN]	6,5	10,1	14,5	19,8	25,9	40,4	48,1-63,1	57,0-79,2	69,6-103,4
	43°C/72°C ¹⁾	C20/25	appr. V [kN]	6,5	10,1	14,5	19,8	25,9	35,0-40,4	44,9-63,1	56,3-79,2	69,6-103,4
Spacing and edge distance												
Min. thickness of concrete slab for $h_{ef,min} - h_{ef,max}$	h_{min}	[mm]		100-126	100-150	102-176	111-204	120-232	138-288	164-364	182-406	208-464
Minimum spacing	s_{min}	[mm]		40	50	60	70	80	100	125	140	160
Minimum edge distance	c_{min}	[mm]		40	50	60	70	80	100	125	140	160
Installation parameters												
Drill hole diameter	d_o	[mm]		12	14	16	18	20	24	32	35	40
Range of drill hole depth for $h_{ef,min} - h_{ef,max}$	h_o	[mm]		60 - 96	60 - 120	70 - 144	75 - 168	80 - 192	90 - 240	100 - 300	112 - 336	128 - 384

¹⁾ Max long term temperature / max short term temperature
Higher concrete strength may lead to higher approved loads.

For anchor designing an easy to operate CD-ROM is available on request or can be downloaded at www.mkt.de.

Post-installed Rebar Connections with Injection System VME



Cartridge VME 385
Side-by-side cartridge
Content: 385ml
With big mixer VM-XL and reducers / extension tube for drill holes from 12mm diameter



Cartridge VME 585
Side-by-side cartridge
Content: 585ml
With big mixer VM-XL and reducers / extension tube for drill holes from 12mm diameter



Cartridge VME 1400
Side-by-side cartridge
Content: 1400ml
With big mixer VM-XL and reducers / extension tube for drill holes from 12mm diameter



Diameter of Rebar: 8 -28 mm
Range of Concrete Quality: C12/15 - C50/60
Material: Reinforcement Bars B 500 B

Description

The Injection System VME for post-installed rebar connections has a European Technical Approval (ETA-07/0299). Reinforcement bars from 8 to 28 mm diameter can be fastened in regular concrete from strength class C12/15 to C50/60. As usual the reinforcement can be designed in accordance with EN 1992-1-1:2004 (EC 2). Using the Tension Anchor ZA in sizes M12, M16 and M20 steel structures can be fixed at minimum edge distance. The hole cleaning procedure for the MKT Injection System VME is much easier when hammer drilling or air drilling. Just blow the holes out using compressed air and the specific MKT cleaning tools. The reduced cleaning results in quicker installation saving labor costs. Installer training is provided by MKT and a certificate will be issued by an independent institute, which is recognized by the DIBt.

Applications

Subsequent closing of wall- and ceiling openings, reinforcing existing concrete structures, installation of reinforcement to connect successive structural members, e.g. if reinforcement has been left out or could not be cast in due to the construction sequence, connection of steel structures.



Injection Cartridge VME



- ➔ Very high loads
- ➔ No shrinkage

Description	Ref. No.	Content ml	Content of master box pcs	Weight per master box kg	Weight per piece kg
Cartridge VME 385	28255501	385	12	8,5	0,70
Cartridge VME 585	28255601	585	12	12,09	0,98
Cartridge VME 1400	28255701	1400	5	12,34	2,40
Static mixer VM-XL	28305201	-	10	0,28	0,03

One static mixer VM-XL including a reducers/extension tube as well as one screw-on cap comes with each cartridge.



System case and accessories for post-installed rebar connection to use with Injection System VMU plus (fast curing time) or the Injection System VME (long curing times, optimized for very large and deep drill holes)

Description and content:

Compact system case including equipment for every rebar diameter as well as all the tools necessary for the installation of post-installed rebar connections using the Injection System VME or VMU plus. All parts also sold separately.



Drilling:

- Drilling aid device
- Flat- / Ring wrench

Accessories for drill hole cleaning:

- 1 of each air hose RS 25 and RS 35
- 1 of each blow-out nozzle RD 12/14, 16/18, 20/25, 30/35
- 1 of each cleaning brush RB 12 M8 – RB 35 M8
- Connection set RS with air valve and connector
- 5 Brush extensions RBL M8, L = 500 mm
- 1 SDS-plus adapter RBL M8-SDS

Accessories for injection:

- 5 Static mixer VM-XL
- 5 of each retaining washer VM-IA Ø12 mm - Ø35 mm
- 5 of each extension tube VM-XE 10/500 and VM-XLE 16/500
- Frame saw

Other:

- Approval
- Installation sheet and Installation report (available for download at www.mkt.de)
- Filling quantity tables
- Adhesive tape
- Measuring tape
- Thermometer
- Ear protection, Breathing protection, Protective goggles and protective gloves

Description	Ref. No.	Suitable for drill hole-Ø mm	Pkg. content pcs.	Weight per piece kg
VME System case	85999101	12 - 35	1	11,8

System Components

- Filling of drill hole
- For drill hole diameter 12 - 35 mm

Description	Ref. No.	Length mm	Rebar-Ø mm	Suitable for drill hole Ø mm	Colour	Package content pcs.	Weight per pkg. kg
Extension tube							
VM-XE 10/1000	85952101	1000	8 - 12	12 - 16	white	10	0,30
VM-XE 10/2000	85954101	2000	8 - 12	12 - 16	white	10	0,65
VM-XLE 16/1000	85956101	1000	14 - 28	18 - 35	grey	10	1,15
VM-XLE 16/2000	85958101	2000	14 - 28	18 - 35	grey	10	3,50
Retaining washer (only for post-installed rebar connections. Fits to the system case)							
VM-IA 12	85912101	-	8	12	white	20	0,04
VM-IA 14	85914101	-	10	14	yellow	20	0,01
VM-IA 16	85916101	-	12	16	blue	20	0,02
VM-IA 18	85918101	-	14	18	black	20	0,01
VM-IA 20	85920101	-	16	20	grey	20	0,02
VM-IA 25	85925101	-	20	25	green	20	0,05
VM-IA 32	85932101	-	25	32	brown	20	0,10
VM-IA 35	85935101	-	28	35	red	20	0,12

Extension pipe VM-XE and VM-XLE can be cut to corresponding drill hole depth. Extension pipe > 2000 mm on demand.

Cleaning Brush RB M8

- Reinforced brushes with connecting thread M8 for deeper drill holes



Description	Ref. No.	Rebar-Ø mm	Suitable for drill hole Ø mm	Pkg. content pcs.	Weight per piece kg
RB 12 M8	85812101	8	12	1	0,05
RB 14 M8	85814101	10	14	1	0,05
RB 16 M8	85816101	12	16	1	0,05
RB 18 M8	85818101	14	18	1	0,05
RB 20 M8	85820101	16	20	1	0,05
RB 25 M8	85825101	20	25	1	0,06
RB 32 M8	85832101	25	32	1	0,08
RB 35 M8	85835101	28	35	1	0,08
Brush extension RBL M8, L= 500 mm	85871101	8 - 28	12 - 35	1	0,32
SDS-Plus adapter RBL M8 SDS	85881101	-	12 - 35	1	0,07

Please select Brush extension RBL and SDS-Plus adapter according to depth of drill hole. For drill hole depth > 500 mm, the proper number of Brush extensions must be connected.

Blow-out nozzle

- Every nozzle cover two drill hole diameter
- Fits on the air hose RS



Description	Ref. No.	Rebar-Ø mm	Suitable for drill hole-Ø mm	Pkg. content pcs.	Weight per piece kg
Blow-out nozzle RD 12/14	85852101	8 - 10	12 - 14	1	0,01
Blow-out nozzle RD 16/18	85854101	12 - 14	16 - 18	1	0,02
Blow-out nozzle RD 20/25	85856101	16 - 20	20 - 25	1	0,03
Blow-out nozzle RD 30/35	85858101	24 - 28	30 - 35	1	0,05

Air hose

- Pre-assembled set with connectors
- To use with air valve and blow-out nozzle



Description	Ref. No.	Rebar-Ø mm	Suitable for drill hole-Ø mm	Pkg. content pcs.	Weight per piece kg
Air hose RS 25 (2 m)	85802101	8 - 20	12 - 25	1	0,10
Air hose RS 35 (3 m)	85804101	24 - 28	30 - 35	1	0,40

Air Valve

- For drill hole cleaning with



Description	Ref. No.	Rebar-Ø mm	Suitable for drill hole-Ø mm	Pkg. content pcs.	Weight per piece kg
Connection Set RS with valve and connector	85890101	8 - 28	12 - 35	1	0,40

Tension Anchor ZA



Thread: M12, M16, M20
Range of Concrete Quality: C12/15 - C50/60
Material: Stainless steel A4/316
On request: Stainless steel HCR

Description

The Tension Anchor ZA consists of a connection thread made of stainless steel A4 or HCR which is welded to a reinforcement bar B 500 B. The Tension Anchor ZA is used with the MKT Injection Adhesive VME and is part of the approvals ETA-07/0299 / Z-21.8-1872. It can be used in cracked and non-cracked concrete and can be designed in accordance with EN 1992-1-1 (EC 2).

Cleaning brushes are required for diamond drilled holes only. If the complete anchorage depth of the Tension Anchor is not required, the reinforcement bar can be cut down to the required length.

Applications

Connection of steel structures to reinforced concrete
 Maximum loads with minimum edge distance possible
 Brackets, canopies, signs, stairs

Tension Anchor ZA



- Stainless steel A4;
High corrosion resistant steel 1.4529 (HCR)
- Approved for cracked and non-cracked concrete



Description	Ref. No.	Drill-hole-Ø mm	max. setting depth mm	Fixture thickness t _{fix} mm	Anchor length mm	Weight per piece kg
ZA M12-60/975 A4	85306501	16	900	60	975	0,9
ZA M12-200/1115 A4	85320501	16	900	200	1115	1,0
ZA M16-60/1180 A4	85506501	20	1100	60	1180	1,9
ZA M16-200/1320 A4	85520501	20	1100	200	1320	2,1
ZA M20-60/1485 A4	85606501	25	1400	60	1485	3,7
ZA M20-200/1625 A4	85620501	25	1400	200	1625	4,0

Stainless steel HCR and other lengths on demand.

Cartridge Injection Adhesive VME see page 135
Dispenser see page 132
System Accessories see page 136



Extract from Permissible Service Conditions of ETA-07/0299 and Z-21.8-1872 for Post-installed Rebar Connections and Tension Anchor ZA with Injection System VME

Concrete Strength		C12/15	C16/20	C20/25	C25/30	C30/37	C35/45	C40/50	C45/55	C50/60
Design value of bond strength f _{bd} [N/mm ²]	Hammer- and pneumatic drilling ¹⁾	1,6	2,0	2,3	2,7	3,0	3,4	3,7	4,0	4,3
	Diamond core drilling ²⁾	1,6	2,0	2,3	2,7	3,0	3,0	3,4	3,7	3,7

¹⁾ Minimum anchorage lengths l_{o,min} and l_{o,min} according to EN 1992-1-1

²⁾ Minimum anchorage lengths l_{o,min} and l_{o,min} given in the EN 1992-1-1 for anchorages and overlap splices shall be multiplied by the factor 1.5 for diamond core drilling

Installation parameters

Tension Anchor ZA		ZA M12	ZA M16	ZA M20	ZA M24
RebarØ	[mm]	12	16	20	25
Drill hole diameter	d _o [mm]	16	20	25	32
Diameter of clearance hole	d _r [mm]	14	18	22	26
Effective setting depth	l _v [mm]	according to static calculation			
Installation torque	≤ T _{inst} [Nm]	50	100	150	150
Width across nut	SW [mm]	19	24	30	36
max. lap length	l _o [mm]	800	1000	1300	1650
max. tension load	appr. N [kN]	35,1	62,4	97,6	152,5

Rebar connection with VME

Rebar-Ø	[mm]	8	10	12	14	16	20	24	25	26	28
Drill hole-Ø	d _o [mm]	12	14	16	18	20	25	30 ³⁾	32	32	35
Amount of adhesive / 100 mm setting depth	[ml]	7,5	9,0	10,6	12,1	13,6	21,2	30,5	37,6	32,8	41,6

³⁾ Cleaning brush and retaining washer for drill hole diameter 30 mm on demand.

Installation

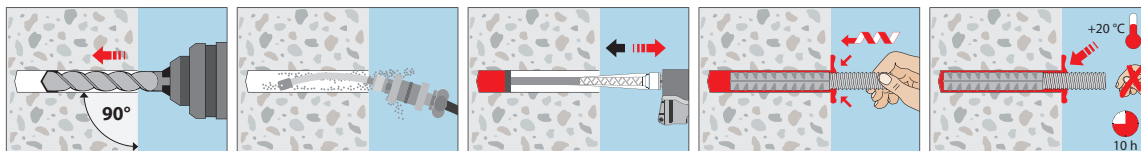

Curing Time Injection adhesive VME

- Cartridge temperature when installing min. +5°C - +40°C

Temperature (°C) of the base material	maximum working time	minimum curing time	
		dry base material	wet base material
+5°C to +9°C	1:00 h	72 h	144 h
+10°C to +19°C	45 min	36 h	72 h
+20°C to +29°C	30 min	10 h	20 h
+30°C to +39°C	20 min	6 h	12 h
40°C	12 min	4 h	8 h

Injection Adhesive VM-PY

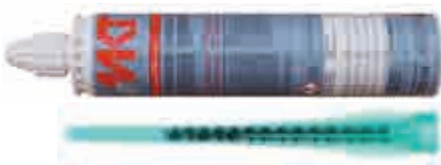

Cartridge VM-PY 300
Foil tube cartridge
suitable for silicon guns
Content: 300ml

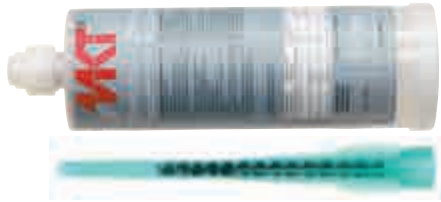

Cartridge VM-PY 410
Coaxial cartridge
Content: 410ml

Range of loading: 0,3 kN - 39,4 kN

Concrete quality: C20/25 - C50/60

Masonry: Solid and perforated brickwork

Description

The Injection Adhesive is a polyester-resin based Injection Adhesive for bonding threaded rods and reinforcing steel in concrete, masonry or natural stone.

Both components are contained in the cartridge and mixed when dispensed through the static mixer. The Injection Adhesive is injected directly into the drilled hole or perfo sleeve with a dispenser gun. The anchoring element is inserted into the filled hole (perfo sleeve) by hand. After the adhesive has cured, the anchoring element can have the load applied.

Advantages

- Suitable for most construction base materials as concrete, masonry, natural stone
- Can be used as a repair adhesive
- Sealed drill-hole
- Opened cartridges can be re-used with a new static mixer
- Suitable for many anchoring elements e.g. threaded rods, female-thread sleeves, concrete steel, hooks, screws etc.



Injection Cartridge VM-PY



- For universal use in most base materials
- For solid and perforated brickwork, concrete

Description	Ref. No.	Content ml	Content of master box pcs	Weight per master box kg	Weight per piece kg
NEW Cartridge VM-PY 300	28252801	300	12	6,40	0,53
Cartridge VM-PY 410	28256002	410	12	9,95	0,83
Static mixer VM-X	28305111	-	12	0,12	0,01
Mixer extension VM-XE 10/200 (200mm)	28306011	-	12	-	-

One static mixer comes with each cartridge.
Usable length of static mixer see page 106.

Threaded Stud for applications in non-cracked concrete and brickwork

Threaded Stud VMU-A

Steel, zinc plated 5.8
Dimensions see page 107



- For use in structures subject to dry internal conditions
- Steel, zinc plated 8.8 on demand

Threaded Stud VMU-A A4

Stainless steel A4
Dimensions see page 107



- For use in structures subject to dry internal conditions or external atmospheric exposure
- Stainless steel HCR on demand

Threaded Stud V-A

Steel, zinc plated 5.8
Dimensions see page 144



- For use in structures subject to dry internal conditions
- Steel, zinc plated 8.8 on demand

Threaded Stud V-A A4

Stainless steel A4
Dimensions see page 144



- For use in structures subject to dry internal conditions or external atmospheric exposure

Threaded Stud V-A fvz

Steel, hot dip galvanized 5.8
Dimensions see page 144



- For use in structures subject to dry internal conditions
- Steel hot dip galvanized 8.8 on demand

Threaded Stud V-A HCR

Stainless steel HCR
Dimensions see page 144



- For use in particularly corrosive environments
- High corrosion resistant steel 1.4529 (HCR)

Threaded stud VM-A

Steel 5.8, zinc plated
Dimensions see page 108



- Threaded studs, of 1 meter length, to be cut to the required length
- Comes with manufacturer's certificate (3.1 EN 10204) in every package

Threaded stud VM-A

Stainless steel A4
Dimensions see page 108



- Threaded studs, of 1 meter length, to be cut to the required length
- Comes with manufacturer's certificate (3.1 EN 10204) in every package

Recommended loads for single anchor without influence of spacing and edge distance for temperature range -40°C to +50°C/+80°C¹⁾.
Total safety factor as per ETAG included (γ_M and γ_p).

Loads and performance data	Injection Adhesive VM-PY with Threaded Studs V-A/VM-A/VMU-A in concrete		non-cracked concrete				
			M8	M 10	M 12	M 16	M20
Rec. loads, tension (Steel 5.8)	$\geq C20/25$	rec. N [kN]	4,4	6,7	9,5	10,7	18,3
Rec. loads, shear (Steel 5.8)	$\geq C20/25$	rec. V [kN]	5,1	8,6	12,0	22,3	34,9
Rec. bending moments (Steel 5.8)		rec. M [Nm]	10,9	21,1	37,1	94,9	185,1
Rec. loads, tension (A4)	$\geq C20/25$	rec. N [kN]	4,4	6,7	9,5	10,7	18,3
Rec. loads, shear (A4)	$\geq C20/25$	rec. V [kN]	6,0	9,2	13,7	25,2	39,4
Rec. bending moments (A4)		rec. M [Nm]	11,9	23,8	42,1	106,2	207,9
Spacing and edge distance							
Effective anchorage depth	h_{ef}	[mm]	80	90	110	125	170
Characteristic spacing	$s_{cr,N}$	[mm]	160	180	220	250	340
Characteristic edge distance	$c_{cr,N}$	[mm]	80	90	110	125	170
Minimum thickness of concrete slab	h_{min}	[mm]	110	120	140	161	218
Minimum spacing	s_{min}	[mm]	40	50	60	80	100
Minimum edge distance	c_{min}	[mm]	40	50	60	80	100
Installation parameters							
Drill hole diameter	d_o	[mm]	10	12	14	18	24
Clearance hole in the fixture	d_f	[mm]	9	12	14	18	22
Depth of drill hole	h_o	[mm]	80	90	110	125	170
Installation torque	T_{inst}	[Nm]	10	20	40	60	120
Width across nut	SW	[mm]	13	17	19	24	30
Amount of adhesive per drill hole		[ml]	5,2	7,3	10,8	17,1	45,4
Drill holes per cartridge VM-PY 410		[pcs.]	71	50	34	21	8

¹⁾ max. long term temperature +50°C / max. short term temperature +80°C

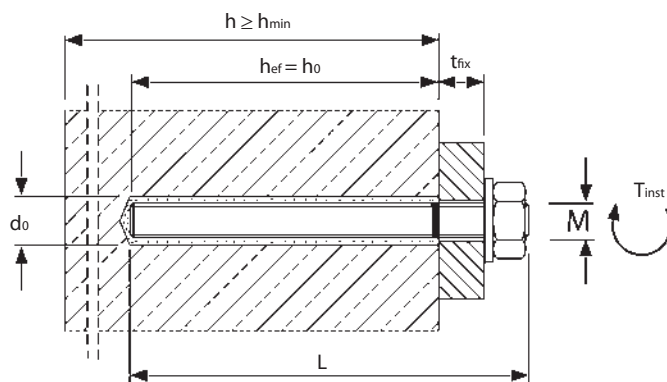

**Curing Time
Injection Adhesive VM-PY**

→ Cartridge temperature when installing min. + 5°C.

Temperature (°C) of base material	working time	curing time
+5°C	25 min	2:00 h
+10°C	15 min	1:20 h
+20°C	6 min	45 min
+30°C	4 min	25 min
+35°C	2 min	20 min

Installation in Concrete

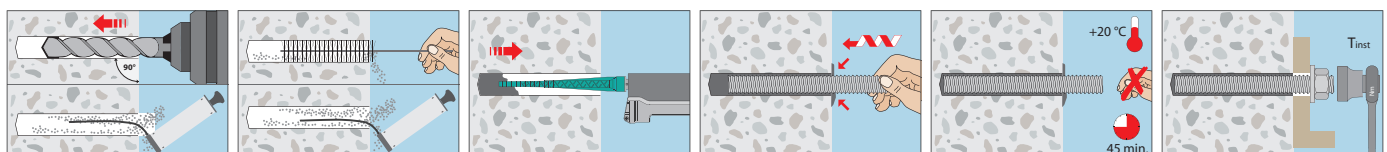

Accessories for Injection Systems

Int. Threaded Sleeve VM-IG



- Steel, zinc plated
- Installation in hollow base materials

Description	Ref. No.	Suitable for perfo sleeve	Internal thread	Outer-ø mm	Length mm	Package content pcs.	Weight per package kg
VM-IG M 6	28101001	VM-SH 12 / 16	M 6	8	45	10	0,11
VM-IG M 8	28102001	VM-SH 16 / 22	M 8	12	80	10	0,38
VM-IG M 10	28103001	VM-SH 20 / 22	M 10	14	80	10	0,45
VM-IG M 12	28104001	VM-SH 22	M 12	16	80	10	0,52

Int. Threaded Sleeve V-IG



- Steel, zinc plated grade 5.8
- Fixture easy to remove; sealed drill hole

Description	Ref. No.	Drill hole Ø x depth mm	Thread Ø x length mm	Package content pcs.	Weight per package kg
V-IG M 8	24105101	14x90	M8x25	10	0,50
V-IG M 10	24205101	16x90	M10x30	10	0,65
V-IG M 12	24305101	18x100	M12x35	10	1,00
V-IG M 16	24505101	25x120	M16x40	10	1,65

Int. Threaded Sleeve V-IG A4



- Stainless steel A4/316
- Fixture easy to remove; sealed drill hole

Description	Ref. No.	Drill hole Ø x depth mm	Thread Ø x length mm	Package content pcs.	Weight per package kg
V-IG M 8 A4	24105501	14x90	M8x25	10	0,50
V-IG M 10 A4	24205501	16x90	M10x30	10	0,65
V-IG M 12 A4	24305501	18x100	M12x35	10	1,00
V-IG M 16 A4	24505501	25x120	M16x40	10	1,65

Perfo Sleeve VM-SH

Polypropylen



- Polypropylene
- Installation in hollow base materials

Description	Ref. No.	Drill hole Ø x depth mm	For threaded studs	For internally threaded sleeves	Suitable for cleaning brush	Package content pcs.	Weight per package kg
			mm				
VM-SH 12 x 50	28151001	13 x 55	M8	-	RB 12 M6	10	0,01
VM-SH 12 x 80	28151201	12 x 85	M8	-	RB 12 M6	10	0,02
VM-SH 16 x 85	28152001	16 x 90	M8 / M10	VMU-IG M6 x 80	RB 16 M6	10	0,03
VM-SH 16 x 130	28153001	16 x 135	M8 / M10	-	RB 16 M6	10	0,04
VM-SH 20 x 85	28154001	20 x 90	M12 / M16	VMU-IG M8 x 80/VMU-IG M10 x 80	RB 20 M6	10	0,04
VM-SH 20 x 130	28154301	20 x 135	M12 / M16	-	RB 20 M6	10	0,07
VM-SH 20 x 200	28154601	20 x 205	M12 / M16	-	RB 20 M6	10	0,10

Perfo Sleeve VM-SH



- Metal, to be cut to required length
- Installation in hollow base materials

Description	Ref. No.	Drill hole Ø mm	Suitable for		Package content pcs.	Weight per package kg
			Threaded Studs	Threaded Sleeve		
VM-SH 12 x 1000	28403001	12	M6-M8	VM-IG M6	50	2,88
VM-SH 16 x 1000	28404001	16	M10	VM-IG M6-M8	50	3,38
VM-SH 22 x 1000	28405001	22	M12-M16	VM-IG M8-M12	25	2,70

Centering Sleeve VM-ZR



- Plastic
- Avoid sliding of Threaded Stud in drill hole.

Description	Ref. No.	For Threaded Studs	Package content pcs.
VM-ZR M 8	28201001	M 8	10
VM-ZR M 10	28202001	M 10	10
VM-ZR M 12	28203001	M 12	10

Cleaning Brush RB M6



RB M6, with connection thread M6



RBL M6, with internal and external thread M6



RBL M6 SDS, with internal thread M6

→ With connection thread M6 – extension for large depths of drill hole and/or for through-setting installation

→ For drilling machines with keyed chuck or with SDS plus adaptor for SDS plus drill holders

Description	Ref. No.	For drill hole Ø mm	Total length of brush mm	Base material	Suitable for Threaded stud	Pkg. cont. pcs	Weight per piece kg
RB 10 M6	33510101	10	130	concrete	M8	1	0,05
RB 12 M6	33512101	12	140	concrete	M10	1	0,05
RB 14 M6	33514101	14	180	concrete	M12	1	0,05
RB 18 M6	33518101	18	200	concrete	M16	1	0,05
RB 24 M6	33524101	24	250	concrete	M20	1	0,06
RB 28 M6	33528101	28	260	concrete	M24	1	0,06
RB 32 M6	33532101	32	350	concrete	M27	1	0,06
RB 35 M6	33535101	35	350	concrete	M30	1	0,08
RBL M6	33968101	Brush extension 150mm with connection thread M6				1	0,09
RBL M6 SDS	33350101	SDS Plus adapter with internal thread M6				1	0,06

Cleaning Brush RB-H



RB-H 18 Nylon, with handle

→ Drill hole cleaning in solid and hollow base material

Description	Ref. No.	For drill hole Ø mm	Base material	Pkg. cont. pcs	Weight per piece kg
RB-H 12/250	29914501	8-12	brickwork	1	0,04
RB-H 18/250	29918501	10-18	brickwork	1	0,04
RB-H 18/400	33618101	10-18	brickwork	1	0,05
RB-H 28/280	29928501	20-28	brickwork	1	0,05

Blow-out pump VM-AP



→ Drill hole cleaning by hand

Description	Ref. No.	Length mm	For drill hole Ø mm	For depth of drill hole mm	Pkg. cont. pcs	Weight per piece kg
Blow-out pump VM-AP 270	29990002	270	≤ 20	≤ 200	1	0,22
Blow-out pump VM-AP 360	33200101	360	≤ 20	≤ 300	1	0,27

Air gun VM-ABP



→ Drill hole cleaning with compressed air

Description	Ref. No.	Nozzle-Ø mm	For drill hole Ø mm	Max. drill hole depth ¹⁾ mm	Pkg. cont. pcs.	Weight per piece kg
VM-ABP 200	33090101	5	6-20	240	1	0,55
VM-ABP 250	33100101	16	18-40	240	1	1,00
VM-ABP 500	33106101	16	18-40	480	1	1,30

Air gun VM-ABP



→ Drill hole cleaning with compressed air for holes up to one meter

→ For best drill hole cleaning the nozzle of the air-gun must reach to the bottom of the drill hole

Description	Ref. No.	Nozzle Ø mm	For Drill hole depth mm	For drill hole Ø mm	Pkg. cont. pcs	Weight per piece kg
VM-ABP 1000	85806101	14	≤ 1000	16-40	1	0,32

Retaining Washer VM-IA



- For bubble-free filling of the drill hole
- Suitable for extension pipes VM-XE and VM-XLE

Description	Ref. No.	Suitable for drill hole Ø mm	Color	Suitable for		Pkg. cont. pcs.	Weight per pkg. kg
				Threaded stud	Rebar		
VM-IA 14	85914201	14	black	M12	Ø10	20	0,02
VM-IA 16	85916201	16	black	-	Ø12	20	0,02
VM-IA 18	85918201	18	black	M16	Ø14	20	0,02
VM-IA 20	85920201	20	black	-	Ø16	20	0,06
VM-IA 24	85924101	24	black	M20	Ø20	20	0,06
VM-IA 25	85925201	25	black	-	Ø20	20	0,06
VM-IA 28	85928101	28	black	M24	Ø22	20	0,08
VM-IA 32	85932201	32	black	M27	Ø24, 25	20	0,08
VM-IA 35	85935201	35	black	M30	Ø28	20	0,08
VM-IA 40	85938201	40	black	-	Ø32	20	0,08

Extension Tubes



- Extension tubes for deeper drill holes
- Two diameters available

Description	Ref. No.	Length mm	Ø mm	To use in conjunction with	Pkg. cont. pcs.	Weight per pkg. kg
VM-XE 10/500	85951101	500	10	VM-XL, VM-X	10	0,20
VM-XLE16/250	85959101	250	16	VM-XL	10	0,30
VM-XLE16/1000	85956101	1000	16	VM-XL	10	1,15

Dispenser VM-P Profi



- Professional dispenser with an ideal center of gravity for more comfortable working
- Automatic pressure release for minimum adhesive overrun

Description	Ref. No.	Suitable for cartridge	Pkg. cont. pcs.	Weight per piece kg
VM-P 345 Profi	28350511	150ml, 280ml, 300ml, 345ml also suitable for silicone cartridges	1	1,00
VM-P 380 Profi	28351001	380ml, 410ml, 420ml	1	1,10

Dispenser VM-P Standard



- For occasional use, metal version
- Piston rod with adjusting screw

Description	Ref. No.	Suitable for cartridge	Pkg. cont. pcs.	Weight per piece kg
VM-P 345 Standard	28350505	150ml, 280ml, 300ml, 345ml also suitable for silicone cartridges	1	1,00
VM-P 380 Standard	28353005	380ml, 410ml, 420ml	1	1,15

Dispenser VM-P Pneumatic



- Professional air tool with an optimum center of gravity and quick cartridge exchange
- Automatic pressure release system reduces adhesive overrun to a minimum
- Single-hand pressure regulation to adjust the piston speed
- With compressed air connection nipple

Description	Ref. No.	Suitable for cartridge	max. working pressure	Pkg. cont. pcs.	Weight per piece kg
VM-P 345 Pneumatic	28350601	345ml	8 bar, 40l/min	1	2,41
VM-P 380 Pneumatic	28352002	380ml, 410ml, 420ml	8 bar, 40l/min	1	2,00

Dispenser VM-P Akku



¹⁾ with Akku 18V/2,0 Ah

- Professional, solid battery cartridge dispenser in a plastic case
- Repeat function, for retrieving the last fill quantity
- Stepless variable pressing speed
- Overrun-quantity-stop by automatic return after release of the dispensing switch

Description	Ref. No.	Suitable for cartridge	Press-out force kN	Weight ¹⁾ kg	Dimensions ¹⁾ L x B x H mm	Pkg. cont. pcs.	Weight per piece kg
VM-P 345 Akku	28350801	345ml	5,0	3,53	395 x 180 x 285	1	7,72
VM-P 380 Akku	28352601	380ml, 410ml, 420ml	3,95	3,62	375 x 180 x 285	1	7,80
Accessories (for all models)							
Replacement battery	28352411			18 V/2,0 Ah		1	1,00
Shoulder strap	28359991			adjustable		1	0,02

NEW

Chemical Anchor V plus



NEW



Range of loading: 5,1 kN – 140,3 kN
 Range of concrete quality: C20/25 - C50/60
 Material: Steel, zinc plated, Steel, hot dip galvanized, Stainless steel A4, HCR

Description

The Chemical Anchor V plus with European Technical Assessment (ETA Option 7) is a further development of the proven Chemical Anchor V with higher approved loads. The system consists of the new glass capsule V-P plus, filled with resin, hardener and filler-material, as well as the Threaded Stud V-A. The components in the capsule are mixed to a fast curing resin-adhesive when the threaded stud is driven into the drill-hole. This stress free anchoring system has been used successfully for decades and allows for mounting of heavy loads even with smaller spacings and edge distances in non-cracked concrete. All Sizes of Threaded Stud V-A are also available in grade 8.8 steel on demand.

Applications

Anchoring of heavy loads in non-cracked concrete: trusses, foot and headplates, consoles, crash-barriers, noise-protection walls.



Advantages:

- Higher load values compared to Chemical Anchor V
- Increase of the approved loads at higher concrete strength
- Anchor-rods with external hexagon for fast and easy installation
- Every package includes an adapter for the drilling machine
- Excellent suitability for high volume fixing
- Sealed drill-hole
- Extensive product range for all uses
- Usable in wet and dry concrete
- Also with large washer for crash-barrier mounting
- Economic special lengths without external hexagon available

Chemical Capsule V-P plus



→ Two component glass capsule

→ Approved for non-cracked concrete

Description	Ref. No.	Capsule Ø	Capsule length	Content of master box	Weight per master box	Package content	Weight per package
		mm	mm	pcs.	kg	pcs.	kg
V-P plus 8	25300801	9	80	500	6,2	10	0,13
V-P plus 10	25301001	11	80	500	7,7	10	0,16
V-P plus 12	25301201	13	95	200	5,3	10	0,27
V-P plus 14	25301401	15	95	200	6,4	10	0,32
V-P plus 16	25301601	17	95	200	8,1	10	0,41
V-P plus 20	25302001	17	160	150	10,8	10	0,72
V-P plus 24	25302401	22	175	100	12,4	10	1,24
V-P plus 30	25303001	25	230	50	10,2	5	1,02

NEW

Chemical Anchors

Threaded Stud V-A



- May be used in structures subject to dry internal conditions
- Steel, zinc plated 5.8
- Approved for non-cracked concrete

Description	Ref. No.	Drill hole Ø x depth mm	Fixture thickness t _{fix} mm	Usable length in concrete ¹⁾ mm	Package content pcs.	Weight per package kg
V-A 8-20/110	21101101	10 x 80	20	100	10	0,43
V-A 8-60/150	21105101	10 x 80	60	140	10	0,53
V-A 10-15/115	21202101	12 x 90	15	105	10	0,73
V-A 10-30/130	21203101	12 x 90	30	120	10	0,81
V-A 10-65/165	21207101	12 x 90	65	155	10	0,98
V-A 10-90/190	21210101	12 x 90	90	180	10	1,11
V-A 10-150/250	21216101	12 x 90	150	240	10	1,42
V-A 10-200/300	21221101	12 x 90	200	290	10	1,71
V-A 12-10/135	21304101	14 x 110	10	120	10	1,19
V-A 12-35/160	21306101	14 x 110	35	145	10	1,37
V-A 12-85/210	21312101	14 x 110	85	195	10	1,73
V-A 12-95/220	21313101	14 x 110	95	205	10	1,82
V-A 12-125/250	21316101	14 x 110	125	235	10	2,02
V-A 12-175/300	21321101	14 x 110	175	285	10	2,83
V-A 14-35/170 ²⁾	21408101	16 x 120	35	155	10	1,91
V-A 16-20/165	21507101	18 x 125	20	145	10	2,77
V-A 16-45/190	21510101	18 x 125	45	170	10	2,96
V-A 16-85/230	21514101	18 x 125	85	210	10	3,65
V-A 16-105/250	21516101	18 x 125	105	230	10	3,91
V-A 16-155/300	21521101	18 x 125	155	280	10	4,58
V-A 20-20/220	21613101	22 x 170	20	190	10	5,56
V-A 20-60/260	21617101	22 x 170	60	230	10	6,39
V-A 20-100/300	21621101	22 x 170	100	270	10	7,23
V-A 24-15/260	21717101	26 x 210	15	225	5	4,89
V-A 24-55/300	21721101	26 x 210	55	265	5	5,54
V-A 30-70/380 ²⁾³⁾	21829101	32 x 280	70	350	5	10,00

Other lengths and grade 8.8 on demand.

¹⁾For VMH/VMU plus/VM-EA/VME

²⁾Not part of assessment

³⁾Setting tool V-A 30-70/380 ref. no. 27805160 to be ordered separately.

Threaded Stud V-A A4



- May be used in structures subject to dry internal conditions or external atmospheric exposure
- Stainless Steel A4
- Approved for non-cracked concrete

Description	Ref. No.	Drill hole Ø x depth mm	Fixture thickness t _{fix} mm	Usable length in concrete ¹⁾ mm	Package content pcs.	Weight per package kg
V-A 8-20/110 A4	21101501	10 x 80	20	100	10	0,43
V-A 8-60/150 A4	21105501	10 x 80	60	140	10	0,53
V-A 10-15/115 A4	21202501	12 x 90	15	105	10	0,73
V-A 10-30/130 A4	21203501	12 x 90	30	120	10	0,81
V-A 10-65/165 A4	21207501	12 x 90	65	155	10	0,98
V-A 10-90/190 A4	21210501	12 x 90	90	180	10	1,11
V-A 10-150/250 A4	21216501	12 x 90	150	240	10	1,42
V-A 10-200/300 A4	21221501	12 x 90	200	290	10	1,71
V-A 12-10/135 A4	21304501	14 x 110	10	120	10	1,19
V-A 12-35/160 A4	21306501	14 x 110	35	145	10	1,37
V-A 12-55/180 A4	21309501	14 x 110	55	165	10	1,51
V-A 12-85/210 A4	21312501	14 x 110	85	195	10	1,73
V-A 12-95/220 A4	21313501	14 x 110	95	205	10	1,82
V-A 12-125/250 A4	21316501	14 x 110	125	235	10	2,02
V-A 12-175/300 A4	21321501	14 x 110	175	285	10	2,83
V-A 14-35/170 A4 ²⁾	21408501	16 x 120	35	155	10	1,91
V-A 16-5/150 A4	21505501	18 x 125	5	130	10	2,38
V-A 16-20/165 A4	21507501	18 x 125	20	145	10	2,77
V-A 16-45/190 A4	21510501	18 x 125	45	170	10	2,96
V-A 16-65/210 A4	21512501	18 x 125	65	190	10	3,20
V-A 16-85/230 A4	21514501	18 x 125	85	210	10	3,65
V-A 16-105/250 A4	21516501	18 x 125	105	230	10	3,91
V-A 16-155/300 A4	21521501	18 x 125	155	280	10	4,58
V-A 20-20/220 A4	21613501	22 x 170	20	190	10	5,56
V-A 20-60/260 A4	21617501	22 x 170	60	230	10	6,39
V-A 20-100/300 A4	21621501	22 x 170	100	270	10	7,23
V-A 24-15/260 A4	21717501	26 x 210	15	225	5	4,89
V-A 24-55/300 A4	21721501	26 x 210	55	265	5	5,54
V-A 30-70/380 A4 ²⁾³⁾	21829501	32 x 280	70	350	5	10,00

Other lengths on demand.

¹⁾For VMH/VMU plus/VM-EA/VME

²⁾Not part of assessment

³⁾Setting tool V-A 30-70/380 ref. no. 27805160 to be ordered separately.

Threaded Stud V-A fvz



- Improved corrosion protection
- Steel, hot dip galvanized 5.8 (≥ 40µm, EN ISO 1461)
- Approved for non-cracked concrete

Description	Ref. No.	Drill hole Ø x depth mm	Fixture thickness t _{fix} mm	Usable length in concrete ¹⁾ mm	Package content pcs.	Weight per package kg
V-A 8-20/110 fvz	21101201	10 x 80	20	100	10	0,43
V-A 10-30/130 fvz	21203201	12 x 90	30	120	10	0,81
V-A 10-90/190 fvz	21210201	12 x 90	90	180	10	1,11
V-A 12-35/160 fvz	21306201	14 x 110	35	145	10	1,37
V-A 12-95/220 fvz	21313201	14 x 110	95	205	10	1,82
V-A 16-20/165 fvz	21507201	18 x 125	20	145	10	2,77
V-A 16-45/190 fvz	21510201	18 x 125	45	170	10	2,96
V-A 16-65/210 fvz	21512201	18 x 125	65	190	10	3,20
V-A 20-20/220 fvz	21613201	22 x 170	20	190	10	5,56
V-A 20-60/260 fvz	21617201	22 x 170	60	230	10	6,39
V-A 24-15/260 fvz	21717201	26 x 210	15	235	5	4,89
V-A 24-55/300 fvz	21721201	26 x 210	55	265	5	5,54

Other lengths and grade 8.8 on demand.

¹⁾For VMH/VMU plus/VM-EA/VME

Threaded Stud V-A HCR



- For use in particularly corrosive environments
- High corrosion resistant steel 1.4529 (HCR)
- Approved for non-cracked concrete

Description	Ref. No.	Drill hole Ø x depth mm	Fixture thickness t _{fix} mm	Usable length in concrete ¹⁾ mm	Package content pcs.	Weight per package kg
V-A 8-20/110 HCR	21101651	10 x 80	20	100	10	0,43
V-A 10-30/130 HCR	21203651	12 x 90	30	120	10	0,81
V-A 12-35/160 HCR	21306651	14 x 110	35	145	10	1,37
V-A 16-45/190 HCR	21510651	18 x 125	45	170	10	2,96

Other lengths on demand.

¹⁾For VMH/VMU plus/VM-EA/VME

Cleaning Brush RB M6



→ With connection thread M6 – extension for large depths of drill hole and/or for through-setting installation

→ For drilling machines with keyed chuck or with SDS plus adapter for SDS plus drills

Description	Ref. No.	Suitable for drill hole Ø mm	Suitable for	Package content pcs.	Weight per piece kg
RB 10 M6	33510101	10	V plus M8	1	0,05
RB 12 M6	33512101	12	V plus M10	1	0,05
RB 14 M6	33514101	14	V plus M12	1	0,05
RB 16 M6	33516101	16	V plus M14	1	0,05
RB 18 M6	33518101	18	V plus M16	1	0,05
RB 22 M6	33522101	22	V plus M20	1	0,06
RB 26 M6	33526101	26	V plus M24	1	0,06
RB 32 M6	33532101	32	V plus M30	1	0,08
RBL M6	33968101	Brush extension 150 mm with connection thread M6		1	0,09
RBL M6 SDS	33350101	SDS Plus adapter for cleaning brush (M6)		1	0,06

Blow-out pump VM-AP



→ Drill hole cleaning

Description	Ref. No.	Suitable for drill hole Ø mm	Length mm	max. depth drill hole mm	Package content pcs.	Weight per piece kg
VM-AP 270	29990002	12-35	270	200	1	0,22
VM-AP 360	33200101	10-35	360	330	1	0,27

Setting Tool V-M



→ Only needed for special length and studs without external Hexagon

Description	Ref. No.	Suitable for threaded stud	Package content pcs.	Weight per piece kg
V-M 8	27105160	M8	1	0,02
V-M 10	27205160	M10	1	0,03
V-M 12	27305160	M12	1	0,05
V-M 14	27405160	M14	1	0,05
V-M 16	27505160	M16	1	0,06
V-M 20	27605160	M20	1	0,20
V-M 24	27705160	M24	1	0,33
V-M 30	27805160	M30	1	0,63



Extract from Permissible Service Conditions of ETA-16/0944.

Approved loads for single anchor without influence of spacing and edge distance for temperature range -40°C to +24°C/+40 °C¹⁾. Total safety factor as per ETAG 001 included (γ_M and γ_P). Temperature range II 80°C/50°C see ETA-16/0944.

Loads and performance data				Chemical anchor V plus with threaded stud V-A steel, zinc plated / hot dip galvanized in concrete							
				M8	M10	M12	M14	M16	M20	M24	M30
non-cracked concrete											
Mean ultimate loads, tension (steel 5.8)	C25/30	Num	[kN]	19,2	30,5	44,3	60,6	82,3	128,5	185,1	294,3
Mean ultimate loads, shear (steel 5.8)	C25/30	Vum	[kN]	11,0	17,4	25,3	34,6	47,0	73,4	105,8	168,2
Mean ultimate loads, tension (steel 8.8)	C25/30	Num	[kN]	30,7	48,0	70,3	88,5	94,1	149,2	204,9	315,5
Mean ultimate loads, shear (steel 8.8)	C25/30	Vum	[kN]	17,6	27,8	40,5	55,4	75,2	117,5	169,2	269,1
Approved loads, tension (steel 5.8)	C20/25	appr. N	[kN]	8,6	13,8	20,0	27,6	33,6	53,3	73,2	93,9
	C25/30	appr. N	[kN]	8,6	13,8	20,0	27,6	36,8	58,4	80,2	102,9
	C30/37	appr. N	[kN]	8,6	13,8	20,0	27,6	37,1	58,6	84,3	114,2
	C40/50	appr. N	[kN]	8,6	13,8	20,0	27,6	37,1	58,6	84,3	131,9
Approved loads, shear (steel 5.8)	C50/60	appr. N	[kN]	8,6	13,8	20,0	27,6	37,1	58,6	84,3	133,8
	≥ C20/25	appr. V	[kN]	5,1	8,0	12,0	16,6	22,3	34,9	50,3	80,0
Appr. bending moments (steel 5.8)		appr. M	[Nm]	10,9	21,1	37,7	60,0	94,9	185,7	320,6	642,9
Approved loads, tension (steel 8.8)	C20/25	appr. N	[kN]	11,5	16,2	23,7	30,2	33,6	53,3	73,2	93,9
	C25/30	appr. N	[kN]	12,2	17,1	25,1	32,0	36,8	58,4	80,2	102,9
	C30/37	appr. N	[kN]	13,1	18,4	27,0	34,4	40,9	63,8	89,0	114,2
	C40/50	appr. N	[kN]	13,8	20,4	29,9	38,0	45,2	70,5	103,5	131,9
	C50/60	appr. N	[kN]	13,8	21,7	31,8	40,4	48,1	75,0	111,1	140,3
Approved loads, shear (steel 8.8)	≥ C20/25	appr. V	[kN]	8,6	13,1	19,4	26,3	36,0	56,0	80,6	128,0
		appr. M	[Nm]	17,1	34,3	60,0	96,0	152,0	296,6	512,0	1028,0

Loads and performance data				Chemical anchor V plus with threaded stud V-A stainless steel A4 and HCR in concrete							
				M8	M 10	M 12	M 14	M 16	M20	M24	M30
non-cracked concrete											
Mean ultimate loads, tension	C25/30	Num	[kN]	26,9	42,6	62,0	84,8	94,1	149,2	204,9	318,5
Mean ultimate loads, shear	C25/30	Vum	[kN]	15,4	24,4	35,4	48,5	65,8	102,8	148,1	235,5
Approved loads, tension	C20/25	appr. N	[kN]	9,9	15,3	22,5	30,2	33,6	53,3	73,2	93,9
	C25/30	appr. N	[kN]	9,9	15,3	22,5	30,9	36,8	58,4	80,2	102,9
	C30/37	appr. N	[kN]	9,9	15,3	22,5	30,9	40,9	63,8	89,0	114,2
	C40/50	appr. N	[kN]	9,9	15,3	22,5	30,9	42,0	65,7	94,3	131,3
	C50/60	appr. N	[kN]	9,9	15,3	22,5	30,9	42,0	65,7	94,3	140,3
Approved loads, shear	≥ C20/25	appr. V	[kN]	6,0	9,2	13,7	18,3	25,2	39,4	56,8	89,7
Appr. bending moments		appr. M	[Nm]	11,9	23,8	42,1	66,8	106,7	207,9	359,9	720,7

Spacing and edge distance										
Effective anchorage depth	h_{ef}	[mm]	80	90	110	120	125	170	210	280
Characteristic spacing	$s_{cr,N}$	[mm]	240	270	330	360	375	510	630	840
Characteristic edge distance	$c_{cr,N}$	[mm]	120	135	165	180	187,5	255	315	420
Minimum thickness of concrete slab	≥ h_{min}	[mm]	110	120	140	150	160	220	260	340
Minimum spacing	s_{min}	[mm]	40	45	55	60	65	85	105	140
Minimum edge distance	c_{min}	[mm]	40	45	55	60	65	85	105	140

Installation parameters										
Drill hole diameter	d_o	[mm]	10	12	14	16	18	22	26	32
Clearance hole in the fixture	d_f	[mm]	9	12	14	16	18	22	26	33
Depth of drill hole	h_o	[mm]	80	90	110	120	125	170	210	280
Installation torque	≤ T_{inst}	[Nm]	10	20	40	60	80	120	180	300
Width across nut	SW	[mm]	13	17	19	22	24	30	36	46

¹⁾ Max long term temperature +24 °C / max short term temperature +40 °C .

For anchor designing, an easy to operate Software is available on request or can be downloaded at www.mkt.de

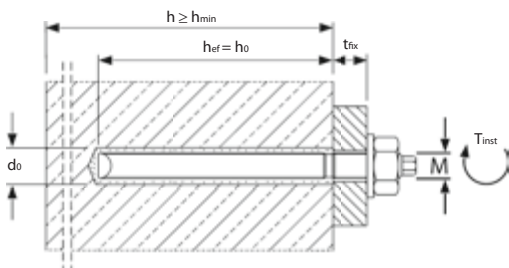

Curing time V plus

→ Capsule temperature when installing min. +5°C

Temperature (°C) of base material	curing time	
	dry base material	wet base material
-5°C to +4°C	5:00 h	10:00 h
+5°C to +19°C	1:00 h	2:00 h
+ 20°C to +29°C	20 min	40 min
≥ +30°C	10 min	20 min

Installation

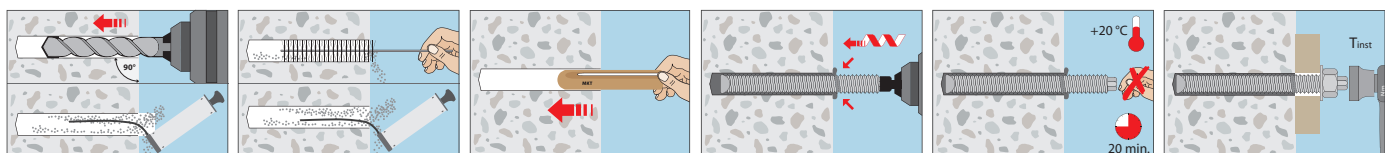

Chemical Anchor V

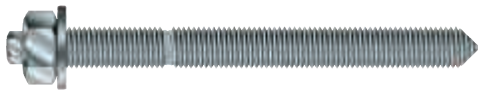

Threaded Stud V-A



Chemical Capsule V-P

Range of loading: 3,0 kN - 80,6 kN

Range of concrete quality: C12/15 - C50/60

Material: Steel, zinc plated, Steel, hot dip galvanized, Stainless steel A4, HCR

Description

The Chemical Anchor V with ETA approval consists of a glass capsule filled with resin, hardener and filler-material, as well as the Threaded Stud V-A. The components in the capsule are mixed to a fast curing resin-adhesive when the threaded stud is inserted into the drill-hole. This stress free anchoring system has been tried and tested for decades and allows for mounting of heavy loads even with smaller spacings and edge distances in non-cracked concrete. All Sizes of Threaded Stud V-A are also available in grade 8.8 steel on demand.

Advantages:

- Anchor-rods with external hexagon for fast and easy installation
- Every package includes an adapter for the drilling machine
- Excellent suitability for high volume fixing
- Sealed drill-hole
- Extensive product range for all uses
- Usable in wet and dry concrete
- Also with large washer for crash-barrier mounting
- Economic special lengths without external hexagon available



Applications

Anchoring of heavy loads in non-cracked concrete: trusses, foot and headplates, consoles, crash-barriers, noise-protection walls.

Chemical Capsule V-P



→ Two component glass capsule

→ Approved for non-cracked concrete

Description	Ref. No.	Capsule Ø	Capsule length	Content of master box	Weight per master box	Package content	Weight per package
		mm	mm	pcs.	kg	pcs.	kg
V-P 8	25100801	9	80	500	7,02	10	0,13
V-P 10	25101001	11	80	500	8,50	10	0,16
V-P 12	25101201	13	95	500	12,30	10	0,25
V-P 14 ¹⁾	25101401	15	95	500	15,82	10	0,27
V-P 16	25101601	17	95	500	19,36	10	0,36
V-P 20	25102001	22	175	-	-	10	1,20
V-P 24	25102401	24	210	-	-	5	0,87
V-P 30 ¹⁾	25103001	33	265	-	-	5	2,64

¹⁾ Not part of approval.

Threaded Stud V-A



- For use in structures subject to dry internal conditions
- Steel, zinc plated 5.8
- Approved for non-cracked concrete

Description	Ref. No.	Drill hole Ø x depth mm	Fixture thickness t _{fix} mm	Usable length in concrete ¹⁾ mm	Package content pcs.	Weight per package kg
V-A 8-20/110	21101101	10 x 80	20	100	10	0,43
V-A 8-60/150	21105101	10 x 80	60	140	10	0,53
V-A 10-15/115	21202101	12 x 90	15	105	10	0,73
V-A 10-30/130	21203101	12 x 90	30	120	10	0,81
V-A 10-65/165	21207101	12 x 90	65	155	10	0,98
V-A 10-90/190	21210101	12 x 90	90	180	10	1,11
V-A 10-150/250	21216101	12 x 90	150	240	10	1,42
V-A 10-200/300	21221101	12 x 90	200	290	10	1,71
V-A 12-10/135	21304101	14 x 110	10	120	10	1,19
V-A 12-35/160	21306101	14 x 110	35	145	10	1,37
V-A 12-85/210	21312101	14 x 110	85	195	10	1,73
V-A 12-95/220	21313101	14 x 110	95	205	10	1,82
V-A 12-125/250	21316101	14 x 110	125	235	10	2,02
V-A 12-175/300	21321101	14 x 110	175	285	10	2,83
V-A 14-35/170 ²⁾	21408101	16 x 120	35	155	10	1,91
V-A 16-20/165	21507101	18 x 125	20	145	10	2,77
V-A 16-45/190	21510101	18 x 125	45	170	10	2,96
V-A 16-85/230	21514101	18 x 125	85	210	10	3,65
V-A 16-105/250	21516101	18 x 125	105	230	10	3,91
V-A 16-155/300	21521101	18 x 125	155	280	10	4,58
V-A 20-20/220	21613101	25 x 170	20	190	10	5,56
V-A 20-60/260	21617101	25 x 170	60	230	10	6,39
V-A 20-100/300	21621101	25 x 170	100	270	10	7,23
V-A 24-15/260	21717101	28 x 210	15	225	5	4,89
V-A 24-55/300	21721101	28 x 210	55	265	5	5,54
V-A 30-70/380 ²⁾³⁾	21829101	35 x 280	70	350	5	10,00

Other lengths and grade 8.8 on demand.

¹⁾For VMH/VMU plus/VM-EA/VME

²⁾Not part of approval.

³⁾Setting tool V-A 30-70/380 ref. no. 27805160 to be ordered separately.

Threaded Stud V-A A4



- For use in structures subject to dry internal conditions or external atmospheric exposure
- Stainless Steel A4
- Approved for non-cracked concrete

Description	Ref. No.	Drill hole Ø x depth mm	Fixture thickness t _{fix} mm	Usable length in concrete ¹⁾ mm	Package content pcs.	Weight per package kg
V-A 8-20/110 A4	21101501	10 x 80	20	100	10	0,43
V-A 8-60/150 A4	21105501	10 x 80	60	140	10	0,53
V-A 10-15/115 A4	21202501	12 x 90	15	105	10	0,73
V-A 10-30/130 A4	21203501	12 x 90	30	120	10	0,81
V-A 10-65/165 A4	21207501	12 x 90	65	155	10	0,98
V-A 10-90/190 A4	21210501	12 x 90	90	180	10	1,11
V-A 10-150/250 A4	21216501	12 x 90	150	240	10	1,42
V-A 10-200/300 A4	21221501	12 x 90	200	290	10	1,71
V-A 12-10/135 A4	21304501	14 x 110	10	120	10	1,19
V-A 12-35/160 A4	21306501	14 x 110	35	145	10	1,37
V-A 12-55/180 A4	21309501	14 x 110	55	165	10	1,51
V-A 12-85/210 A4	21312501	14 x 110	85	195	10	1,73
V-A 12-95/220 A4	21313501	14 x 110	95	205	10	1,82
V-A 12-125/250 A4	21316501	14 x 110	125	235	10	2,02
V-A 12-175/300 A4	21321501	14 x 110	175	285	10	2,83
V-A 14-35/170 A4 ²⁾	21408501	16 x 120	35	155	10	1,91
V-A 16-5/150 A4	21505501	18 x 125	5	130	10	2,38
V-A 16-20/165 A4	21507501	18 x 125	20	145	10	2,77
V-A 16-45/190 A4	21510501	18 x 125	45	170	10	2,96
V-A 16-65/210 A4	21512501	18 x 125	65	190	10	3,20
V-A 16-85/230 A4	21514501	18 x 125	85	210	10	3,65
V-A 16-105/250 A4	21516501	18 x 125	105	230	10	3,91
V-A 16-155/300 A4	21521501	18 x 125	155	280	10	4,58
V-A 20-20/220 A4	21613501	25 x 170	20	190	10	5,56
V-A 20-60/260 A4	21617501	25 x 170	60	230	10	6,39
V-A 20-100/300 A4	21621501	25 x 170	100	270	10	7,23
V-A 24-15/260 A4	21717501	28 x 210	15	225	5	4,89
V-A 24-55/300 A4	21721501	28 x 210	55	265	5	5,54
V-A 30-70/380 A4 ²⁾³⁾	21829501	35 x 280	70	350	5	10,00

Other lengths on demand.

¹⁾For VMH/VMU plus/VM-EA/VME

²⁾Not part of approval.

³⁾Setting tool V-A 30-70/380 ref. no. 27805160 to be ordered separately.

Threaded Stud V-A fvz



- Improved corrosion protection
- Steel, hot dip galvanized 5.8 (≥ 40µm, EN ISO 1461)
- Approved for non-cracked concrete

Description	Ref. No.	Drill hole Ø x depth mm	Fixture thickness t _{fix} mm	Usable length in concrete ¹⁾ mm	Package content pcs.	Weight per package kg
V-A 8-20/110 fvz	21101201	10 x 80	20	100	10	0,43
V-A 10-30/130 fvz	21203201	12 x 90	30	120	10	0,81
V-A 10-90/190 fvz	21210201	12 x 90	90	180	10	1,11
V-A 12-35/160 fvz	21306201	14 x 110	35	145	10	1,37
V-A 12-95/220 fvz	21313201	14 x 110	95	205	10	1,82
V-A 16-20/165 fvz	21507201	18 x 125	20	145	10	2,77
V-A 16-45/190 fvz	21510201	18 x 125	45	170	10	2,96
V-A 16-65/210 fvz	21512201	18 x 125	65	190	10	3,20
V-A 20-20/220 fvz	21613201	25 x 170	20	190	10	5,56
V-A 20-60/260 fvz	21617201	25 x 170	60	230	10	6,39
V-A 24-15/260 fvz	21717201	28 x 210	15	235	5	4,89
V-A 24-55/300 fvz	21721201	28 x 210	55	265	5	5,54

Other lengths and grade 8.8 on demand.

¹⁾For VMH/VMU plus/VM-EA/VME

Threaded Stud V-A HCR



- For use in particularly corrosive environments
- High corrosion resistant steel 1.4529 (HCR)
- Approved for non-cracked concrete

Description	Ref. No.	Drill hole Ø x depth mm	Fixture thickness t _{fix} mm	Usable length in concrete ¹⁾ mm	Package content pcs.	Weight per package kg
V-A 8-20/110 HCR	21101651	10 x 80	20	100	10	0,43
V-A 10-30/130 HCR	21203651	12 x 90	30	120	10	0,81
V-A 12-35/160 HCR	21306651	14 x 110	35	145	10	1,37
V-A 16-45/190 HCR	21510651	18 x 125	45	170	10	2,96

Other lengths on demand.

¹⁾For VMH/VMU plus/VM-EA/VME

Chemical Anchor V-L



→ Steel, hot dip galvanized; Stainless steel

→ Set, specially designed for crash barriers

Description	Ref. No.	Drill hole Ø x depth mm	Stud Ø x length mm	Fixture thickness t _{fix} mm	Package content pcs.	Weight per set kg
V-L 16-20/165 hot dip galvanized washer DIN125 (Ø=30 mm)	23507201	18x125	M16x165	20	10	3,13
V-L 16-20/165 hot dip galvanized washer DIN9021 (Ø=50 mm)	23507791	18x125	M16x165	20	10	3,32
V-L 16-20/165 stainless steel A4/316 washer DIN125 (Ø=30 mm)	23507501	18x125	M16x165	20	10	3,13

Cleaning Brush RB M6



→ With connection thread M6 – extension for large depths of drill hole and/or for through-setting installation

→ For drilling machines with keyed chuck or with SDS plus adaptor for SDS plus drill holder

Description	Ref. No.	Suitable for drill hole Ø mm	Suitable for	Package content pcs.	Weight per piece kg
RB 10 M6	33510101	10	V M8	1	0,05
RB 12 M6	33512101	12	V M10	1	0,05
RB 14 M6	33514101	14	V M12/V-IG M8	1	0,05
RB 16 M6	33516101	16	V M14/V-IG M10	1	0,05
RB 18 M6	33518101	18	V M16/V-IG M12	1	0,05
RB 26 M6	33526101	25, 26	V M20/V-IG M16	1	0,06
RB 28 M6	33528101	28	V M24	1	0,06
RB 35 M6	33535101	35	V M30	1	0,08
RBL M6	33968101	Brush extension 150 mm with connection thread M6		1	0,09
RBL M6 SDS	33350101	SDS Plus adapter for cleaning brush (M6)		1	0,06

Blow-out pump VM-AP



→ Drill hole cleaning

Description	Ref. No.	Suitable for drill hole Ø mm	Length mm	max. depth drill hole mm	Package content pcs.	Weight per piece kg
VM-AP 270	29990002	12-35	270	200	1	0,22
VM-AP 360	33200101	10-35	360	330	1	0,27

Setting Tool V-M



→ Only needed for special length and studs without external Hexagon

Description	Ref. No.	Suitable for threaded stud	Package content pes.	Weight per piece kg
V-M 8	27105160	M8	1	0,02
V-M 10	27205160	M10	1	0,03
V-M 12	27305160	M12	1	0,05
V-M 14	27405160	M14	1	0,05
V-M 16	27505160	M16	1	0,06
V-M 20	27605160	M20	1	0,20
V-M 24	27705160	M24	1	0,33
V-M 30	27805160	M30	1	0,63



Extract from Permissible Service Conditions of ETA-05/0231

Approved loads for single anchor without influence of spacing and edge distance for temperature range -40 °C to +50°C/+80 °C²⁾. Total safety factor as per ETAG 001 included (γ_M and γ_P).

Loads and performance data		Chemical Anchor V, steel, zinc plated / hot dip galvanized		M8	M10	M12	M14 ¹⁾	M16	M20	M24	M30 ¹⁾
non-cracked concrete											
Mean ultimate loads, tension (steel 5.8) C25/30	N _{um}	[kN]		18,3	29,0	42,1	57,7	78,3	123,0	177,0	280,3
Mean ultimate loads, shear (steel 5.8) C25/30	V _{um}	[kN]		11,0	17,4	25,3	34,6	47,0	73,8	106,2	168,2
Mean ultimate loads, tension (steel 8.8) C25/30	N _{um}	[kN]		27,0	38,6	58,2	73,5	104,3	169,8	250,2	442,9
Mean ultimate loads, shear (steel 8.8) C25/30	V _{um}	[kN]		15,0	23,2	33,7	46,2	63,0	98,0	141,0	224,3
Recommended loads, tension	C12/15 ¹⁾ rec. N	[kN]		3,0	5,0	7,0	8,0	10,0	19,0	26,0	42,0
Approved loads, tension	≥ C20/25 appr. N	[kN]		7,9	11,9	15,9	12,0	19,8	29,8	35,7	60,0
Recommended loads, shear	C12/15 ¹⁾ rec. V	[kN]		3,0	5,0	7,0	8,0	10,0	19,0	26,0	42,0
Approved loads, shear	≥ C20/25 appr. V	[kN]		5,1	8,0	12,0	12,0	22,3	34,9	50,3	60,0
Approved loads, shear (steel, grade 8.8)	≥ C20/25 appr. V	[kN]		8,6	13,1	18,9	-	36,0	56,0	80,6	-
Approved bending moments (steel, grade 5.8)	appr. M	[Nm]		10,9	21,1	37,1	59,4	94,9	185,7	320,6	642,0
Approved bending moments (steel, grade 8.8)	appr. M	[Nm]		17,1	34,3	60,0	-	152,0	296,6	513,1	-
		Chemical Anchor V, stainless steel A4 / HCR		M8	M10	M12	M14 ¹⁾	M16	M20	M24	M30 ¹⁾
non-cracked concrete											
Mean ultimate loads, tension C25/30	N _{um}	[kN]		26,0	38,6	58,2	73,5	104,3	169,8	247,0	280,3
Mean ultimate loads, shear C25/30	V _{um}	[kN]		13,0	20,3	29,5	40,4	55,0	86,0	124,0	140,2
Recommended loads, tension	C12/15 ¹⁾ rec. N	[kN]		3,0	5,0	7,0	8,0	10,0	19,0	26,0	42,0
Approved loads, tension	≥ C20/25 appr. N	[kN]		7,9	11,9	15,9	12,0	19,8	29,8	35,7	60,0
Recommended loads, shear	C12/15 ¹⁾ rec. V	[kN]		3,0	5,0	7,0	8,0	10,0	19,0	26,0	42,0
Approved loads, shear	≥ C20/25 appr. V	[kN]		6,0	9,2	13,3	12,0	25,2	39,4	56,8	60,0
Approved bending moments	appr. M	[Nm]		11,9	23,8	42,1	66,9	106,7	207,9	359,4	402,0
Spacing and edge distance											
Effective anchorage depth	h _{ef}	[mm]		80	90	110	120	125	170	210	280
Spacing	Scr,N	[mm]		240	180	220	300	250	340	420	700
Edge distance	Ccr,N	[mm]		120	90	110	150	125	170	210	350
Minimum spacing	S _{min}	[mm]		40	45	55	120	65	85	105	280
Minimum edge distance	C _{min}	[mm]		40	45	55	60	65	85	105	140
Minimum thickness of concrete slab	h _{min}	[mm]		110	120	140	170	160	220	260	330
Installation parameters											
Drill hole diameter	d _o	[mm]		10	12	14	16	18	25	28	35
Clearance hole in the fixture	d _f	[mm]		9	12	14	16	18	22	26	33
Depth of drill hole	h _o	[mm]		80	90	110	120	125	170	210	280
Installation torque	T _{inst}	[Nm]		10	20	40	60	80	120	180	400
Width across nut	SW	[mm]		13	17	19	22	24	30	36	46
Width across nut (Threaded Stud)	SW	[mm]		5	6	8	10	12	14	17	-

¹⁾Not part of approval. Recommended loads for size M14 and M30 and in concrete C12/15.

²⁾Max long term temperature +50 °C / max short term temperature +80 °C

For anchor designing an easy to operate CD-ROM is available on request or can be downloaded at www.mkt.de.

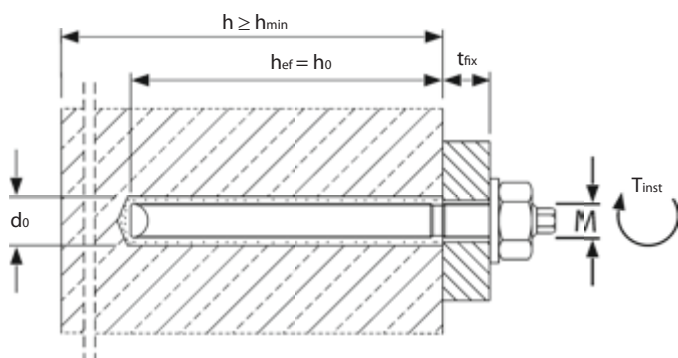

Curing time V

→ Capsule temperature when installing min. +5°C

Temperature (°C) of base material	curing time	
	dry base material	wet base material
-5°C to +4°C	5:00 h	10:00 h
+5°C to +19°C	1:00 h	2:00 h
+ 20°C to +29°C	20 min	40 min
≥ +30°C	10 min	20 min

Installation

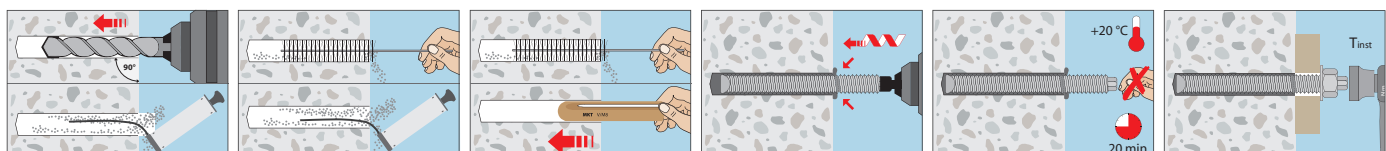

Chemical Anchor V-IG / V-IG A4



Internally Threaded Sleeve V-IG
steel, zinc plated 5.8



Internally Threaded Sleeve V-IG A4
Stainless steel A4



Chemical Capsule V-P

Range of loading: 5,2 kN - 25,1 kN

Range of concrete quality: C20/25 - C50/60

**Material: Steel, zinc plated
Stainless steel A4/316**

Description

The Chemical Anchor V-IG / V-IG A4 is the Internally Threaded Version of the Chemical Anchor V. The system consists of a glass capsule and a threaded stud. The two components contained in the capsule are mixed while the threaded stud is driven in, forming a fast setting adhesive. This time proven anchoring system does not apply expansion forces and allows for very close anchor spacing and edge distances in non-cracked concrete. The drill hole is sealed by the adhesive.



Applications

No security-relevant heavy duty anchorings in non-cracked concrete of steel supports, base plates, consoles, anti-noise barriers.

Chemical Capsule V-P



- Two component glass capsule
- Suitable in non-cracked concrete

Description	Ref. No.	Capsule Ø mm	Capsule length mm	Content of master box pcs.	Weight per master box kg	Package content pcs.	Weight per package kg
V-P 12	25101201	13	95	500	12,30	10	0,25
V-P 14	25101401	15	95	500	15,82	10	0,27
V-P 16	25101601	17	95	500	19,36	10	0,36
V-P 16 IG ¹⁾	25202201	22	115	-	-	10	0,98

¹⁾ For Internally Threaded Sleeve V-IG M 16.

Accessories for drill hole cleaning see page 149.

Internally Threaded Sleeve V-IG



- Steel, zinc plated, grade 5.8
- Fixture easy to remove; sealed drill hole

Description	Ref. No.	Suitable for capsule	Outer-Ø x Anchor length mm	Drill hole Ø x depth mm	Thread mm	Package content pcs.	Weight per package kg
V-IG M 8	24105101	V-P 12	12 x 90	14 x 90	M8 x 25	10	0,50
V-IG M 10	24205101	V-P 14	14 x 90	16 x 90	M10 x 30	10	0,65
V-IG M 12	24305101	V-P 16	16 x 100	18 x 100	M12 x 35	10	1,00
V-IG M 16	24505101	V-P 16 IG	22 x 120	25 x 120	M16 x 40	10	1,65

One setting tool is enclosed in every Internally Threaded Sleeve package.

Internally Threaded Sleeve V-IG A4



- Stainless steel A4/316
- Fixture easy to remove; sealed drill hole

Description	Ref. No.	Suitable for capsule	Outer-Ø x Anchor length mm	Drill hole Ø x depth mm	Thread mm	Package content pcs.	Weight per package kg
V-IG M 8 A4	24105501	V-P 12	12 x 90	14 x 90	M8 x 25	10	0,50
V-IG M 10 A4	24205501	V-P 14	14 x 90	16 x 90	M10 x 30	10	0,65
V-IG M 12 A4	24305501	V-P 16	16 x 100	18 x 100	M12 x 35	10	1,00
V-IG M 16 A4	24505501	V-P 16 IG	22 x 120	25 x 120	M16 x 40	10	1,65

One setting tool is enclosed in every Internally Threaded Sleeve package.

Recommended loads for single anchor without influence of spacing and edge distance for temperature range -40 °C to +50°C/+80 °C¹⁾.
 Total safety factor as per ETAG 001 included (γ_M and γ_P).

Loads and performance data	Chemical Anchor V-IG	M 8		M 10		M 12		M 16		
		steel 5.8	A4-70	steel 5.8	A4-70	steel 5.8	A4-70	steel 5.8	A4-70	
non-cracked concrete C20/25										
Mean ultimate loads, tension	Num	[kN]	20,4	46,7	31,9	54,6	46,2	77,4	86,4	96,8
Mean ultimate loads, shear	V _{um}	[kN]	12,1	15,5	19,1	24,4	27,8	35,4	51,7	65,8
Recommended loads, tension	rec. N	[kN]	8,8	9,9	13,2	13,2	16,0	16,0	18,8	18,8
Recommended loads, shear	rec. V	[kN]	5,2	5,9	8,3	9,3	12,0	13,5	22,4	25,1
Recommended bending moments	rec. M	[Nm]	10,7	12,1	21,4	24,1	37,4	41,9	94,9	107,0
Spacing and edge distance										
Effective anchorage depth	h _{ef}	[mm]	90		90		100		120	
Characteristic spacing	s _{cr, N}	[mm]	225		225		250		480	
Characteristic edge distance	c _{cr, N}	[mm]	115		115		125		240	
Minimum spacing	s _{min}	[mm]	45		45		50		75	
Minimum edge distance	c _{min}	[mm]	45		45		50		75	
Minimum thickness of concrete slab	h _{min}	[mm]	140		160		180		260	
Installation parameters										
Drill hole diameter	d _o	[mm]	14		16		18		25	
Clearance hole in the fixture	d _r	[mm]	9		12		14		18	
Depth of drill hole	h ₁	[mm]	90		90		100		120	
Installation torque	≤T _{inst}	[Nm]	10		20		40		80	

¹⁾ Max long term temperature +50 °C / max short term temperature +80 °C

Curing Time Chemical Anchor V-IG

→ Capsule temperature when installing min. +5°

Temperature (°C) of base material	curing time	
	dry base material	wet base material
-5°C to +4°C	5:00 h	10:00 h
+5°C to +19°C	1:00 h	2:00 h
+20°C to +29°C	20 min	40 min
≥ +30°C	10 min	20 min

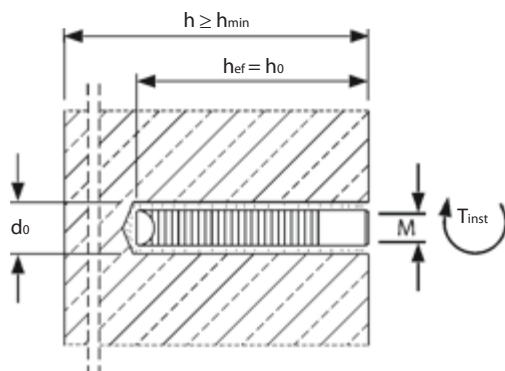

Installation

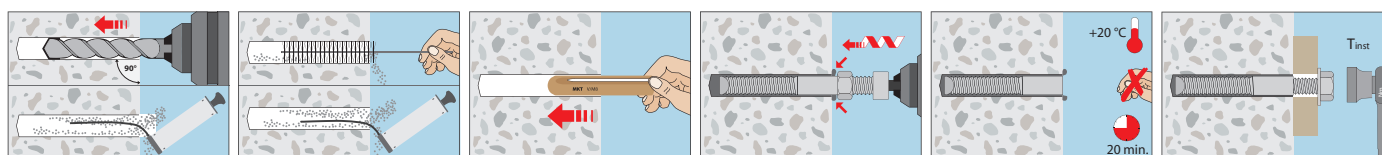

Hollow drill bit SB



Hollow drill bit SB

Description

The hollow drill bit SB combines two steps in one: it drills and at the same time removes the drilling dust from the hole. As a result, it significantly reduces the dust created, resulting in a cleaner work space and reduces air contamination. Thanks to its SDS shank and its 38mm suction pipe connection, it can be used universally and flexibly with any SDS hammer drill and industrial vacuum cleaners.

Advantages

- 98% less air borne dust than during conventional drilling processes
- Permitted for use with approved anchors
- The separate cleaning of the drill hole can be omitted if this is permitted in the ETA
- Easy handling, insert in a hammer drill and connect to an industrial vacuum cleaner

- Efficient dust extraction and drilling thanks to extra large vacuum holes
- Optimum health and safety at the workplace, reduce respiratory complaints of dust particles by using an industrial vacuum cleaner of the M-Class
- Can be used with all standard SDS-max and SDS-plus hammer drills in conjunction with commercial industrial vacuum cleaners
- Save money and time: there is no dirt generated, so no need to clean up afterwards

Hollow drill bit with SDS-plus shank

→ 2-cutter with big vacuum holes for a fast drilling

Description	Ref.No.	Ø mm	Drilling depth mm	Total length mm	Adaptor	Type	Pkg. Content pcs.	Weight per pcs. kg
Hollow drill bit SB plus 8x270	50235501	8	150	270	SDS-plus	2-cutter	1	0,19
Hollow drill bit SB plus 10x270	50245501	10	150	270	SDS-plus	2-cutter	1	0,22
Hollow drill bit SB plus 12x320	50256001	12	200	320	SDS-plus	2-cutter	1	0,31
Hollow drill bit SB plus 14x370	50266501	14	250	370	SDS-plus	2-cutter	1	0,39
Hollow drill bit SB plus 16x370	50286501	16	250	370	SDS-plus	2-cutter	1	0,43
Hollow drill bit SB plus 18x370	50296501	18	250	370	SDS-plus	2-cutter	1	0,53
Hollow drill bit SB plus 20x370	50306501	20	250	370	SDS-plus	2-cutter	1	0,64
Hollow drill bit SB plus 24x370	50326501	24	250	370	SDS-plus	2-cutter	1	0,81

Hollow drill bit with SDS-max shank

→ Y-Cutter for more stable drilling

Description	Ref.No.	Ø mm	Drilling depth mm	Total length mm	Adaptor	Type	Pkg. Content pcs.	Weight per pcs. kg
Hollow drill bit SB max 18x600	50698001	18	400	600	SDS-max	Y-cutter	1	0,99
Hollow drill bit SB max 24x600	50728001	24	400	600	SDS-max	Y-cutter	1	1,21
Hollow drill bit SB max 25x600	50738001	25	400	600	SDS-max	Y-cutter	1	1,23

Suction bell ASG



Description	Ref.No.	Connection diameter to a vacuum cleaner Ø [mm]	Suitable for drill hole Ø [mm]	Pkg. Content pcs.	Weight per pc. kg
Suction bell ASG	29980001	30-38	6-32	1	0,06

Description

For removing drilling dust when drilling or cleaning holes.

Advantages

- Easy handling, connection to a vacuum cleaner is sufficient
- No mounting is necessary, because the suction bell sticks tight to floor, wall and ceiling by a strong vacuum
- Prevents contamination and provides a clear visibility due to almost dust-free drilling
- Reduce respiratory complaints due to tiny dust particles by using a vacuum cleaner of the M-Class

Light Duty Anchors

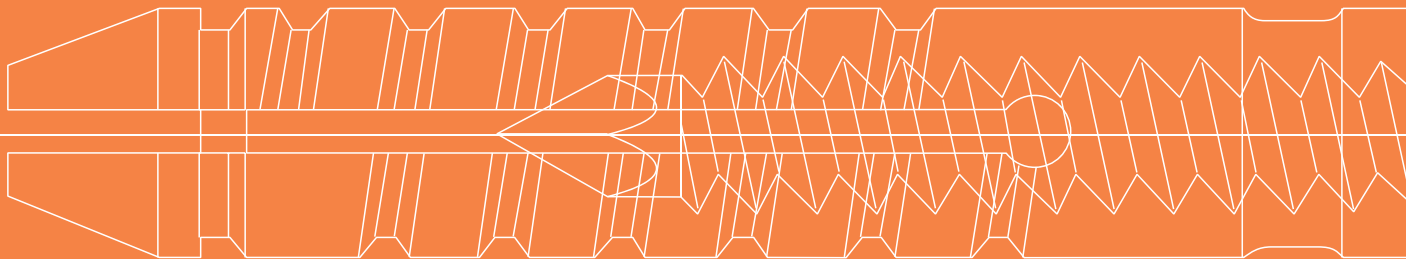

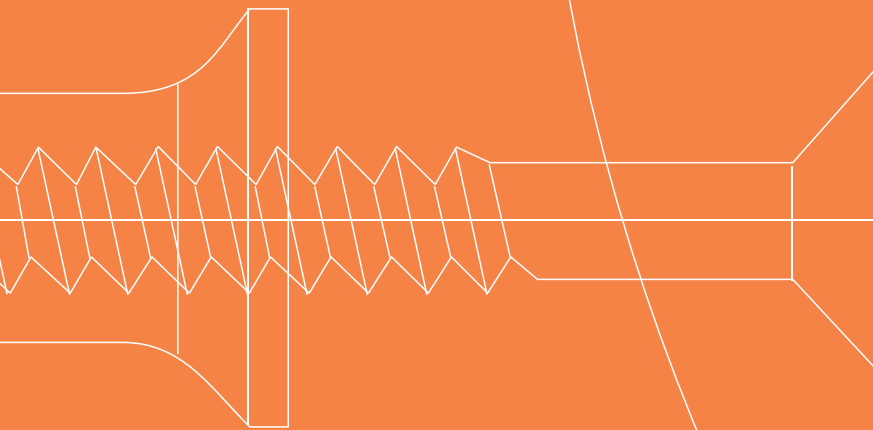

Nail Plug ND



Nail Plug ND-S

Nail Plug ND-Z



Range of loading: 0,04 kN - 0,36 kN

Description

The Nail Plug ND is a time saving hammer-in nylon plug with pre-assembled zinc plated nail-screw, suitable for most types of base materials. It is weather-proof and temperature-resistant from -40°C to 80°C. The Nailplug can be unscrewed for readjustment or removing.

Applications

Frames, skirting boards, wood battens, pipe clips, angles, brackets.

Nail Plug ND

→ High grade polyamide with zinc plated nailscrew

→ With countersunk head and cylindrical head

Description	Ref. No. Typ ND-S counter sunk	Ref. No. Typ ND-Z cheese head	Anchor length mm	Fixture thickness t _{fix} mm	Head Ø Plasticsleeve ND-S/ND-Z mm	Head Ø Nail ND-S/ND-Z mm	Package content ND-S/ND-Z pcs.	Packages per master box ND-S/ND-Z	Weight per master box ND-S/ND-Z kg
ND 5/30	70105101	70105181	30	5	9	8,4	100 / 100	36 / 36	9,9 / 9,9
ND 5/40	70115101	-	40	15	9	8,4	100 / -	27 / -	9,6 / -
ND 6/35	70205101	70205181	35	5	10	9	100 / 100	16 / 16	6,4 / 6,4
ND 6/50	70220101	70220181	50	20	10	9	100 / 100	16 / 16	8,3 / 8,3
ND 6/60	70230101	-	60	30	10	9	100 / -	16 / -	8,3 / -
ND 6/75	70245101	-	75	45	10	9	100 / -	16 / -	11,8 / -
ND 8/60	70305101	70305181	60	20	13	12	100 / 100	8 / 9	8,7 / 9,8
ND 8/80	70315101	70315181	80	40	13	12	100 / 100	8 / 8	10,6 / 10,6
ND 8/100	70325101	-	100	60	13	12	100 / -	8 / -	12,9 / -
ND 8/120	70335101	-	120	80	13	12	100 / -	8 / -	13,8 / -
ND 8/140	70345101	70345181	140	100	13	12	100 / 50	6 / 8	10,1 / 13,5

Loads, any direction

			ND 5	ND 6	ND 8
Recommended loads, concrete C20/25	rec. F	[kN]	0,18	0,26	0,36
Recommended loads, solid brick MZ 12	rec. F	[kN]	0,16	0,22	0,30
Recommended loads, aerated concrete G2	rec. F	[kN]	0,04	0,06	0,08
Effective anchorage depth	h _{ef}	[mm]	25	30	40

Installation parameters

			ND 5	ND 6	ND 8
Drill hole diameter	d _o	[mm]	5	6	8
Depth of drill hole	h ₁	[mm]	35	40	50

Installation

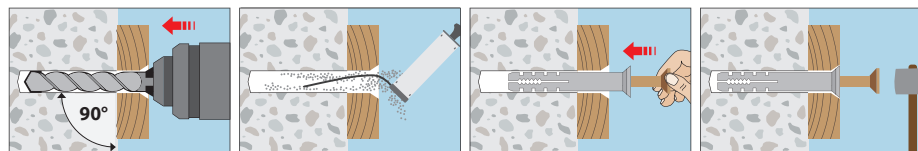

Universal Plug UD



Universal Plug UD



Universal Plug UD-K

Description

The time proven design of the Universal Plug UD guarantees reliable and safe fastenings in practically all types of base materials. To be used with woodscrews.

Applications

Electric switches, cables, curtain rails, battens, bathroom appliances, shelves, lightweight cupboards.



Range of loading: 0,12 kN - 1,2 kN

Universal Plug UD



- High quality plastic material
- For nearly all types of base materials

Description	Ref. No. Type UD	Ref. No. Type UD-K	Anchor length	Screw Ø	Package content	Packages per master box		Weight per master box kg	
						UD	UD-K	UD	UD-K
UD 5/31	71010101	71010181	31	3-4	100	54	54	2,8	2,8
UD 6/36	71110101	71110181	36	4-5	100	36	36	3,0	3,0
UD 8/51	71210101	71210181	51	5-6	50	27	27	3,0	3,0
UD 10/61	71310101	71310181	61	7-8	25	54	54	4,5	4,5
UD 12/71	71410101	71410181	71	8-10	25	36	27	3,5	2,7
UD 14/75	71510101	71510181	75	10-12	20	27	27	3,5	3,5

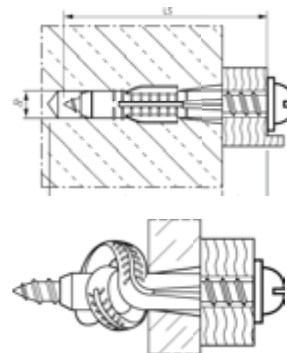

Min. screw length

anchor length
+ thickness of plaster, tile, etc.
+ fixture thickness (accessory)
+ 1 x screw diameter

= min. screw length LS

Loads and performance data			UD 5/31	UD 6/36	UD 8/51	UD 10/61	UD 12/71	UD 14/75
Mean ultimate loads, concrete C20/25	Num	[kN]	0,70	1,50	3,40	3,75	4,70	5,70
Recommended loads, concrete C20/25	rec. F	[kN]	0,14	0,30	0,68	0,75	0,94	1,14
Recommended loads, aircrete P4	rec. F	[kN]	0,12	0,18	0,32	0,42	0,42	-
Recommended loads, hollow brick HLz12	rec. F	[kN]	0,14	0,17	0,24	0,26	0,27	-
Recommended loads, gypsum plasterboard 12,5 mm	rec. F	[kN]	0,12	0,14	0,2	0,2	0,22	0,44 ¹⁾
Effective anchorage depth	hef	[mm]	31	36	51	61	71	75
Installation parameters								
Drill hole diameter ²⁾	d ₀	[mm]	5	6	8	10	12	14
Depth of drill hole	h ₁	[mm]	40	45	60	75	85	90

¹⁾2 x gypsum plasterboard 12,5 mm

²⁾Aerated concrete: Use 1 mm smaller drill bit; hollow base materials: Drill without hammer action.

Installation

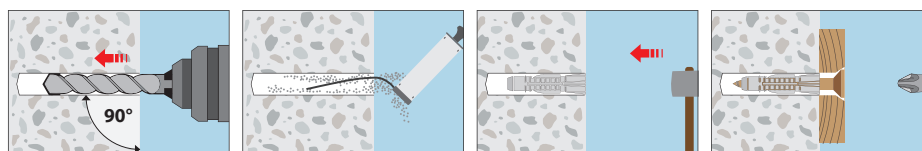

Nylon Standard Plug NSD



Nylon Standard Plug NSD

Description

The nylon standard plug NSD with 2-way expansion is suitable for quick fixings with low loads in concrete and solid masonry. As the hammer-in stop prevents premature spreading, the nylon standard plug NSD is particularly suitable for through fastening, even with pre-assembled screw. The high reliability of assembly is due to large rotation locks that prevent turning in the hole.

Applications

Surface mount boxes, images, letter boxes, curtain rails, towel racks, lamps, baseboards, motion detectors, smoke and fire alarms as well as light panels, plates, hanging cabinets and wall shelves and much more.

Material:

- High-quality polyamide (nylon)
- Halogen-free and silicone-free
- Temperature resistant from -40°C to +80°C

Range of loading: 0,03 kN – 1,9 kN



Nylon Standard NSD



- Suitable for pre-installation and through fastening
- Hold due to high material strength and manufacturing quality

Description	Ref. No.	Ø [mm]	Length [mm]	Woodscrew -Ø [mm]	Chipboard screw-Ø [mm]	Package content [pcs.]	Weight per pck. kg	Packages per master box
NSD 5	65125001	5	25	2,5 - 4	4	100	0,046	4.800
NSD 6	65225001	6	30	3,5 - 5	5	100	0,070	4.800
NSD 8	65425001	8	40	4,5 - 6	6	100	0,145	2.400
NSD 10	65525001	10	50	6 - 8	-	50	0,135	1.200
NSD 12	65625001	12	60	8 - 10	-	25	0,110	600
NSD 14	65725001	14	75	10 - 12	-	20	0,160	480
NSD 16	65825001	16	80	12 - 14	-	10	0,111	240
NSD 20	65925001	20	90	16	-	5	0,200	120

Loads and performance data

Recommended loads, any direction			NSD 5	NSD 6	NSD 8	NSD 10	NSD 12	NSD 14
With Woodscrew-ø	dS	[mm]	4	5	6	8	10	12
Concrete B25; C20/25	rec. F	[kN]	0,25	0,38	0,6	0,9	1,4	1,9
Solid brick Mz12	rec. F	[kN]	0,25	0,3	0,5	-	-	-
Solid sand-slim KS12	rec. F	[kN]	0,25	0,3	0,5	-	-	-
Aerated concrete PP4, PB4	rec. F	[kN]	0,03	0,06	0,1	0,15	0,2	-
Spacing and edge distance								
Setting depth	hs	[mm]	25	30	40	50	60	75
Spacing	a	[mm]	50	60	80	100	120	140
Edge distance	ar	[mm]	25	30	40	50	60	70
Installation parameters								
Drill hole diameter	d _o	[mm]	5	6	8	10	12	14
Depth of drill hole	h _o	[mm]	35	40	50	65	75	85
Minimum length of screw	l _s	[mm]	fixture thickness + anchor length + 1 x screw diameter					

Installation

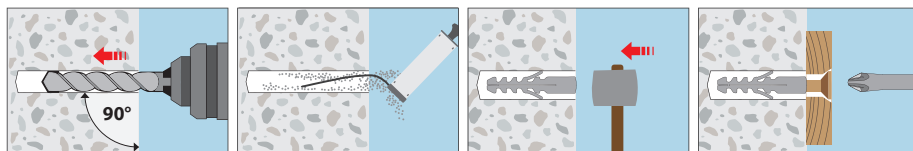

User tip
Since the plug spreads in two directions only, turn the plug, when using close to the edge, so that the spreading force acts parallel to the edge.

Safety Nail TDN



Safety Nail TDN



Safety Nail TDN-O

Description

The Safety Nail TDN is a hammer-in steel anchor for cracked and non-cracked concrete, with fire resistance classification, vandal-proof. Supplied pre-assembled.

Applications

Suspended ceilings, ventilation systems, claddings, brackets, metal sheet.

Load Range: 0,5 kN - 2,4 kN



Safety Nail TDN



- Steel, zinc plated
- For cracked and non-cracked concrete

Description	Ref. No.	Drill hole Ø mm	Fixture thickness mm	Eye - Ø mm	Package content pcs.	Weight per package kg
TDN 6/5	72210101	6 x 40	5	-	100	1,0
TDN 6/65	72230101	6 x 40	35	-	100	1,8
TDN-O ¹⁾	72250101	6 x 45	-	9	100	2,5

¹⁾Not part of the approval



Extract from Permissible Service Conditions of ETA-06/0259

Multiple use for non-structural applications. Total safety factor as per ETAG 001 included (γ_M and γ_p). The maximum load per fixing point for multiple use for non-structural applications may, depending on national regulations, are below the approved load of the anchor. The approved loads per fixing point are regulated for their respective countries in the ETAG 001, Part 6.

Loads and performance data			TDN 6/5	TDN 6/35	TDN-O ¹⁾
			concrete C20/25 to C50/60		
Approved loads, any direction	appr.F	[kN]	2,4	2,4	0,5
Loads under fire exposure (C20/25 to C50/60)					
Approved loads R 30	appr.F	[kN]	0,8	0,8	-
Approved loads R 60	appr.F	[kN]	0,7	0,7	-
Approved loads R 90	appr.F	[kN]	0,6	0,6	-
Approved loads R 120	appr.F	[kN]	0,4	0,4	-
Spacing and edge distance					
Effective anchorage depth	h _{ef}	[mm]	32	32	33
Minimum spacing	s _{min}	[mm]	200	200	200
Minimum edge distance	c _{min}	[mm]	150	150	150
Minimum thickness of concrete slab	h _{min}	[mm]	80	80	100
Installation parameters					
Drill hole diameter	d ₀	[mm]	6	6	6
Depth of drill hole	h ₁	[mm]	40	40	45
Head diameter		[mm]	15	15	-

¹⁾Not part of European Technical Assessment

Installation

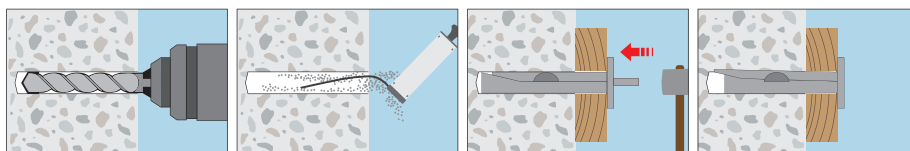

Drywall Plug GKD



Description

The Drywall Plug GKD is a selfdrilling metal plug with twin cutting tip for fastening into drywall. Suitable for screws of Ø 4 to 4,5 mm and M4.

Applications

Fixing of switches, curtain rods, wall cupboards, lamps, cable ducts, skirting boards.



Range of loading: 0,10 - 0,15 kN

Drywall Plug GKD



→ Self-drilling plug for drywall

→ Perfect centering tip

Description	Ref. No.	Anchor length mm	Suitable for screws mm	Package content pcs.	Weight per package kg	Content per master box pcs.
GKD 39	37305001	39	Ø 4,0 - 4,5	100	0,68	2400

Loads and performance data				GKD 39	
Mean ultimate loads, drywall d=12,5mm		N _{um}	[kN]	0,45	
Mean ultimate loads, aerated concrete LC 25/28		N _{um}	[kN]	0,40	
Mean ultimate loads, gypsum panel		N _{um}	[kN]	1,00	
Recommended loads, drywall d=12,5mm		rec. N	[kN]	0,10	
Recommended loads, aerated concrete LC 25/28		rec. N	[kN]	0,10	
Recommended loads, gypsum panel		rec. N	[kN]	0,15	

Installation

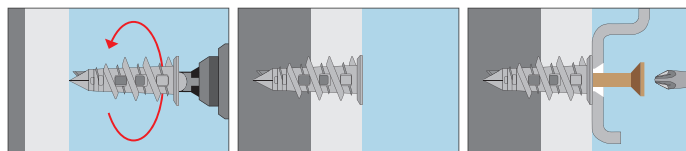

Service

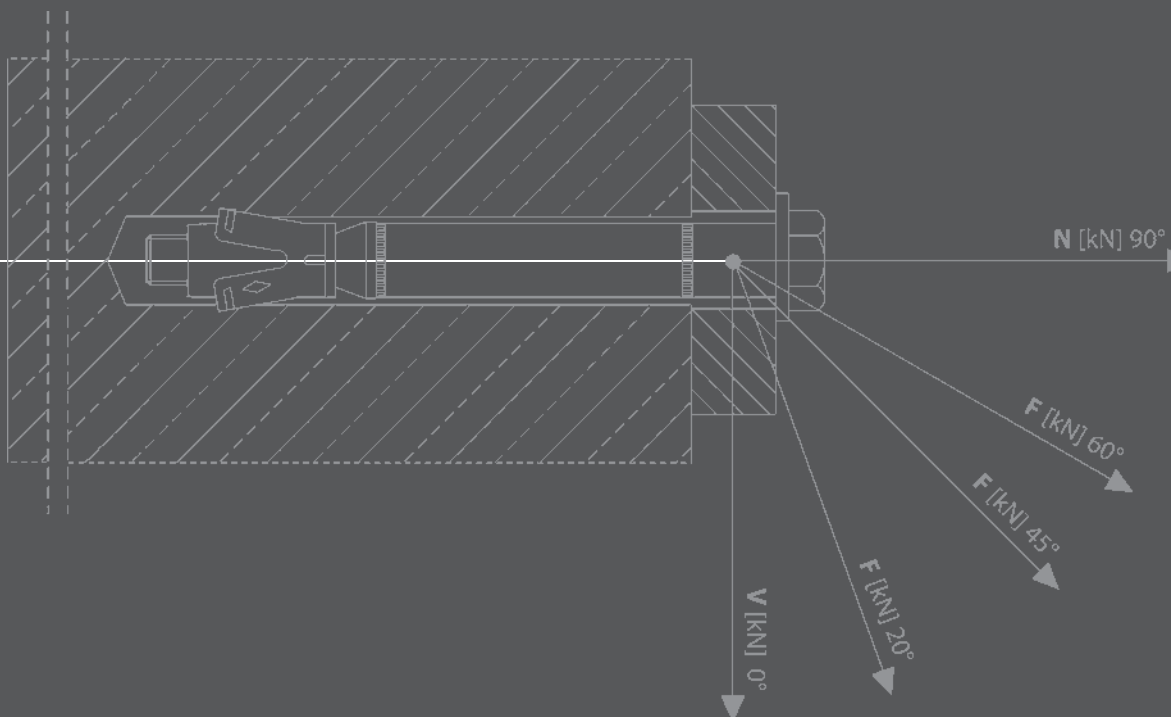



Mechanical Heavy Duty Anchors

Chemical Anchors

Light Duty Anchors

Service

MKT Anchor Design Software



Software for an easy and fast design of anchoring connections.

The software:

- Easy and clear input
- Detailed display of results
- For single anchors and anchor groups, small edge distances, spaced fixings
- Detailed printout

Design according to European design guideline :

- Guideline for European Technical Approval of Metal Anchors, ETAG 001, Annex C
- Guideline for European Technical Approval of Metal Anchors, ETAG 001, Part 6 (multiple use)
- Technical Report TR 020 (Design of Anchorages in Concrete Concerning Fire Resistance)
- Technical Report TR029 (Design of Bonded Anchors)
- Technical Report TR045 (Design under seismic action)

→ Easy and fast design of anchoring connections

→ Clear input, detailed printout

→ Design according to CC-method, ETAG annex C

PC requirements:

- Windows XP (SP 3) / Vista / Windows 7 / Windows 8 / Windows 10

Please order our MKT software or use our free download service at www.mkt.de

MKT Anchor Design Software 4.30

new in 4.30:

- Faster dimensioning with a result preview on the input mask
- Design under seismic action for BZ **plus**, SZ, BSZ, VMZ, VME, VMU **plus**
- Design of the MKT Concrete Screw BSZ according to the new European Technical Assessment

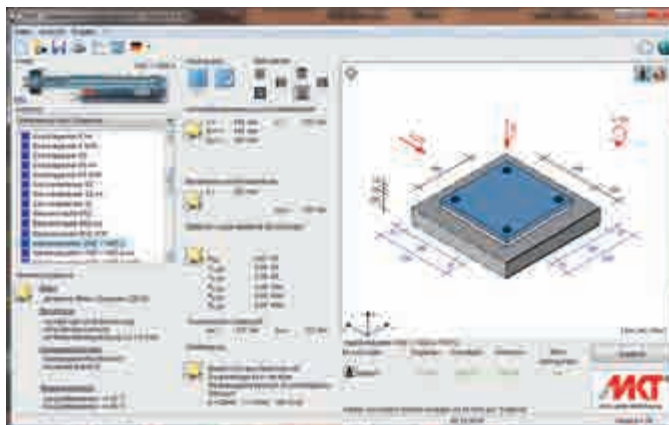

 → Product information

 → Download

 → Support

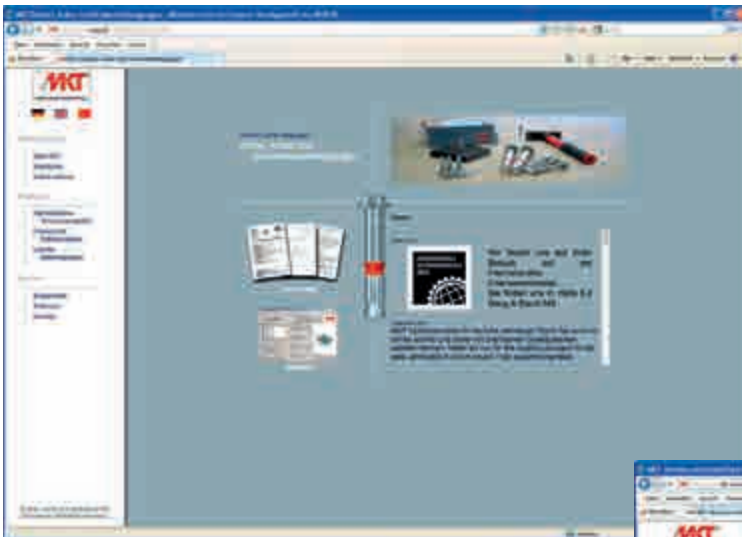

Product information

Contains detailed information and technical data for our product range.

Download



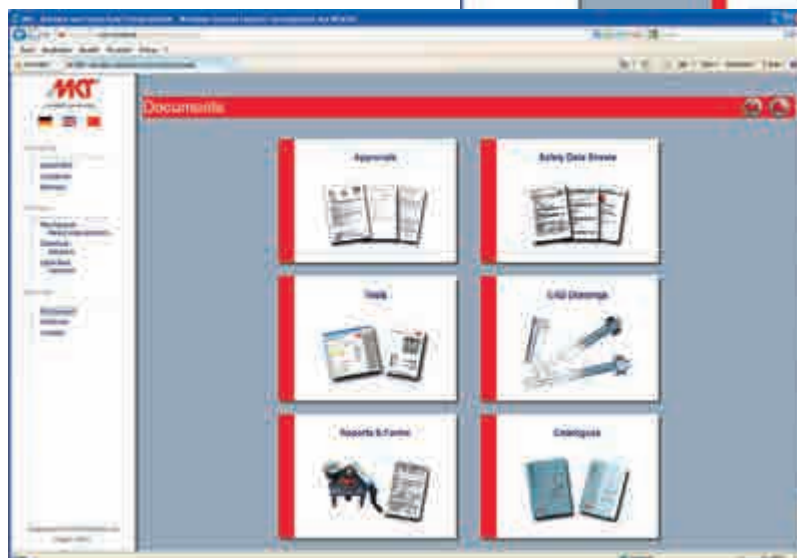



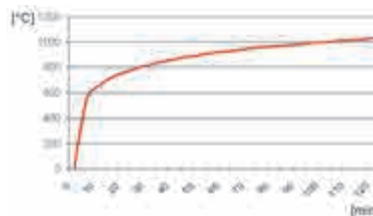

Software, approvals, certificates and data sheets can be downloaded from our website.

















Fire Resistant Anchor Systems

Tested according to standardized temperature curve (ISO 834, DIN EN 1363-1: 1999-10, DIN 4102-2: 1977-09) in cracked concrete, exposed to open flames, without fire protection.



Anchor system	Documents	Size	Maximum tension load in fire tests for the fire resistance classes			
			R 30 (30 min)	R 60 (60 min)	R 90 (90 min)	R 120 (120 min)
Wedge Anchor BZ plus Steel, zinc plated 	ETA-99/0010	M 8 $h_{ef,red}/h_{ef,std}$	1,25/1,25	1,10/1,10	0,80/0,80	0,60/0,70
		M 10 $h_{ef,red}/h_{ef,std}$	1,82/2,25	1,82/1,90	1,30/1,40	1,00/1,20
		M 12 $h_{ef,red}/h_{ef,std}$	3,18/4,00	3,00/3,00	1,90/2,40	1,30/2,20
		M 16 $h_{ef,red}/h_{ef,std}$	4,72/6,25	4,72/5,60	3,50/4,40	2,50/4,00
		M 20 $h_{ef,std}$	9,00	8,20	6,90	6,30
		M 24 $h_{ef,std}$	11,10	11,10	10,00	8,88
Wedge Anchor BZ plus A4 / HCR Stainless steel A4/316, Stainless steel 1.4529 	ETA-99/0010	M 8 $h_{ef,red}/h_{ef,std}$	1,25/1,25	1,25/1,25	1,25/1,25	1,00/1,00
		M 10 $h_{ef,red}/h_{ef,std}$	1,82/2,25	1,82/2,25	1,82/2,25	1,46/1,80
		M 12 $h_{ef,red}/h_{ef,std}$	3,18/4,00	3,18/4,00	3,18/4,00	2,55/3,20
		M 16 $h_{ef,red}/h_{ef,std}$	4,72/6,25	4,72/6,25	4,72/6,25	3,77/5,00
		M 20 $h_{ef,std}$	9,00	9,00	9,00	7,20
		M 24 $h_{ef,std}$	10,00	10,00	10,00	8,00
Wedge Anchor BZ-IG Steel, zinc plated 	ETA-99/0010	M 6	0,70	0,60	0,50	0,40
		M 8	1,40	1,20	0,90	0,80
		M 10	2,50	2,00	1,50	1,30
		M 12	3,70	2,90	2,20	1,80
Wedge Anchor BZ-IG A4 / HCR Stainless steel A4/316, Stainless steel 1.4529 	ETA-99/0010	M 6	1,25	1,25	1,00	0,50
		M 8	2,25	2,25	2,10	1,30
		M 10	3,00	3,00	3,00	2,40
		M 12	5,00	5,00	5,00	4,00
Wedge Anchor B, B-U Steel, zinc plated/hot dip galvanised 	Evaluation 21716/2	M 6 $h_{ef,red}/h_{ef,std}$	0,60/0,60	0,50/0,50	0,30/0,30	0,30/0,30
		M 8 $h_{ef,red}/h_{ef,std}$	0,80/0,80	0,70/0,70	0,60/0,60	0,50/0,50
		M 10 $h_{ef,red}/h_{ef,std}$	1,80/1,80	1,50/1,50	1,00/1,00	0,80/0,80
		M 12 $h_{ef,red}/h_{ef,std}$	3,20/3,40	2,80/2,80	1,70/1,70	1,20/1,20
		M 16 $h_{ef,red}/h_{ef,std}$	4,60/6,30	4,60/5,20	3,20/3,20	2,30/2,30
		M 20 $h_{ef,red}/h_{ef,std}$	6,20/9,00	6,20/8,20	5,00/5,00	3,60/3,60
Wedge Anchor B A4 / B HCR Stainless steel A4/Stainless steel 1.4529 	Evaluation 21716/2	M 6 $h_{ef,red}/h_{ef,std}$	0,90/1,80	0,90/1,40	0,90/0,90	0,70/0,70
		M 8 $h_{ef,red}/h_{ef,std}$	1,30/2,30	1,30/2,30	1,30/2,10	1,00/1,00
		M 10 $h_{ef,red}/h_{ef,std}$	2,10/2,90	2,10/2,90	2,10/2,90	1,60/2,20
		M 12 $h_{ef,red}/h_{ef,std}$	3,20/6,10	3,20/6,10	3,20/4,80	2,50/3,90
		M 16 $h_{ef,red}/h_{ef,std}$	4,60/6,40	4,60/6,40	4,60/6,40	3,70/5,20
		M 20 $h_{ef,red}/h_{ef,std}$	6,20/9,00	6,20/9,00	6,20/9,00	5,00/7,20
Nail Anchor N, N-K, N-M Steel, zinc plated/Stainless steel A4/Stainless steel HCR  With threaded rod $\geq 5,8$	ETA-11/0240	N $h_{ef} = 25$	0,60	0,60	0,50	0,40
		N-K $h_{ef} = 25$	0,60	0,60	0,60	0,50
		N-M $h_{ef} = 25$	0,60	0,60	0,60	0,50
		N $h_{ef} = 30$	0,90	0,70	0,50	0,40
		N-K $h_{ef} = 30$	0,90	0,80	0,60	0,50
		N-M $h_{ef} = 30$	0,80	0,70	0,60	0,60
		N A4, N-K A4 $h_{ef} = 30$	0,90	0,90	0,90	0,70
		N-M A4 $h_{ef} = 30$	0,80	0,70	0,60	0,60
Drop-in Anchor E Steel, zinc plated / Stainless steel A4/316 / Stainless steel HCR  with screw $\geq 5,6$ or Stainless steel A4/316 ¹⁾ ¹⁾ Standard thread version or with screw 4.6/4.8 see evaluation	Evaluation 21725/1	M 6 x 30	0,90	0,70	0,40	0,30
		M 8 x 30	0,90	0,90	0,80	0,50
		M 8 x 40	1,80	1,30	0,80	0,50
		M 10 x 30	0,90	0,90	0,90	0,70
		M 10 x 40	1,80	1,80	1,20	0,80
		M 12 x 50	3,20	3,10	1,80	1,20
		M 12 x 80	4,30	3,10	1,80	1,20
		M 16 x 65	4,70	4,70	3,30	2,20
		M 16 x 80	6,40	5,70	3,30	2,20
		M 20 x 80	6,40	6,40	5,20	3,40





Anchor system	Documents	Size	Maximum tension load in fire tests for the fire resistance classes			
			R 30 (30 min)	R 60 (60 min)	R 90 (90 min)	R 120 (120 min)
Drop-in Anchor E/ES Multiple use for non-structural applications according to ETAG 001, Part 6 Steel, zinc plated  with screw $\geq 5.6^{1)}$ ¹⁾ With threaded rod or with screw 4.6/4.8 see ETA-05/0116	ETA-05/0116	M 6 x 25	0,40	0,35	0,30	0,25
		M 6 x 30	0,80	0,80	0,40	0,30
		M 8 x 25	0,60	0,60	0,60	0,50
		M 8 x 30	0,90	0,90	0,90	0,50
		M 8 x 40	1,50	1,50	0,90	0,50
		M 10 x 25	0,60	0,60	0,60	0,50
		M 10 x 30	0,90	0,90	0,90	0,70
		M 10 x 40	1,50	1,50	1,50	1,00
		M 12 x 25	0,60	0,60	0,60	0,50
		M 12 x 50	1,50	1,50	1,50	1,20
		M 16 x 65	4,00	4,00	3,70	2,40
Drop-in Anchor E/ES A4 / HCR Multiple use for non-structural applications according to ETAG 001, Part 6 Stainless steel A4, stainless steel 1.4529 	ETA-05/0116	M 6 x 30	0,80	0,80	0,40	0,30
		M 8 x 30	0,90	0,90	0,90	0,50
		M 8 x 40	1,50	1,50	0,90	0,50
		M 10 x 40	1,50	1,50	1,50	1,00
		M 12 x 50	1,50	1,50	1,50	1,20
M 16 x 65	4,00	4,00	3,70	2,40		
Hollow Core Anchor EASY Steel, zinc plated/Web thickness $d_w \geq 30$ mm  (Web thickness $d_w \geq 40$ mm see approval)	Z-21.1-1785	M 6	0,70	0,60	0,40	0,20
		M 8	0,90	0,90	0,70	0,40
		M 10	1,20	1,20	1,20	1,00
		M 12	1,20	1,20	1,20	1,20
Highload Anchor SZ Steel, zinc plated 	ETA-02/0030	M 6	1,00	0,80	0,60	0,40
		M 8	1,90	1,50	1,00	0,80
		M 10	4,00	3,20	2,10	1,50
		M 12	6,30	4,60	3,00	2,00
		M 16	9,00	8,60	5,00	3,10
		M 16L	11,10	8,60	5,00	3,10
		M 20	12,58	12,58	7,70	4,90
M 24	16,53	16,53	12,60	9,20		
Highload Anchor SZ A4 Stainless steel A4 	ETA-02/0030	M 8	2,30	2,30	2,30	1,80
		M 10	4,00	4,00	4,00	2,80
		M 12	6,40	6,40	6,40	4,10
		M 16	9,00	9,00	9,00	7,20
Highload Anchor SLZ Steel, zinc plated 	ETA-09/0342	M 10	0,90	0,80	0,60	0,50
Concrete screw BSZ Steel, zinc plated/Steel, zinc flake coated 	ETA-16/0204	BSZ 6 h _{nom} 40	0,50	0,50	0,50	0,40
		BSZ 6 h _{nom} 55	0,90	0,80	0,60	0,40
		BSZ 8 h _{nom} 45	1,30	1,30	1,10	0,70
		BSZ 8 h _{nom} 55	2,20	1,70	1,10	0,70
		BSZ 8 h _{nom} 65	2,40	1,70	1,10	0,70
		BSZ 10 h _{nom} 55	2,20	2,20	2,20	1,70
		BSZ 10 h _{nom} 75	4,20	3,30	2,30	1,70
		BSZ 10 h _{nom} 85	4,40	3,30	2,30	1,70
		BSZ 12 h _{nom} 65	3,00	3,00	3,00	2,40
		BSZ 12 h _{nom} 85	4,90	4,90	4,20	3,40
		BSZ 12 h _{nom} 100	6,40	5,80	4,20	3,40
		BSZ 14 h _{nom} 75	4,00	4,00	4,00	3,20
		BSZ 14 h _{nom} 100	6,30	6,30	5,90	4,80
BSZ 14 h _{nom} 115	7,90	7,90	5,90	4,80		
Concrete screw BSZ Multiple use for non-structural applications according to ETAG 001, Part 6 Steel, zinc plated/Steel, zinc flake coated 	ETA-16/0439	BSZ 6 h _{nom} 35	0,38	0,38	0,38	0,30
		BSZ 6 h _{nom} 55	0,90	0,80	0,60	0,40

Anchor system	Documents	Size	Maximum tension load in fire tests for the fire resistance classes			
			R 30 (30 min)	R 60 (60 min)	R 90 (90 min)	R 120 (120 min)
Concrete screw BSZ A4 Stainless steel A4 	ETA-16/0204	BSZ 6 h _{nom} 40	0,50	0,50	0,50	0,40
		BSZ 6 h _{nom} 55	0,90	0,80	0,60	0,40
		BSZ 8 h _{nom} 45	1,30	1,30	1,10	0,70
		BSZ 8 h _{nom} 55	2,20	1,70	1,10	0,70
		BSZ 8 h _{nom} 65	2,40	1,70	1,10	0,70
		BSZ 10 h _{nom} 55	2,20	2,20	2,20	1,70
		BSZ 10 h _{nom} 75	4,20	3,30	2,30	1,70
BSZ 10 h _{nom} 85	4,40	3,30	2,30	1,70		
Concrete screw BSZ A4 Multiple use for non-structural applications according to ETAG 001, Part 6 	ETA-16/0439	BSZ 6 h _{nom} 35	0,38	0,38	0,38	0,30
		BSZ 6 h _{nom} 55	1,20	1,20	1,20	0,80
Injection System VMZ Steel, zinc plated/Stainless steel A4/316 and 1.4529 	Evaluation GS 32/17-340-2	≥ 50 M 8	1,04	0,47	---	---
		≥ 60 M 10	2,50	1,45	0,39	---
		≥ 80 M 12	5,80	3,80	1,81	0,81
		≥ 125 M 16	7,62	5,81	4,01	3,11
		≥ 170 M 20	13,02	9,75	6,48	4,84
Injection System VMH Steel, zinc plated ≥ grade 5.8/Stainless steel A4/316 ≥ grade 70 and 1.4529 ≥ grade 70 	Evaluation 21806	M8 h _{ef} ≥ 85	0,71	0,56	0,41	0,33
		M10 h _{ef} ≥ 95	1,42	1,11	0,79	0,63
		M12 h _{ef} ≥ 105	3,03	2,28	1,60	1,18
		M16 h _{ef} ≥ 120	5,65	4,24	2,98	2,20
		M20 h _{ef} ≥ 135	8,82	6,62	4,66	3,43
		M24 h _{ef} ≥ 145	12,71	9,53	6,71	4,94
		M27 h _{ef} ≥ 155	16,52	12,39	8,72	6,43
		M30 h _{ef} ≥ 165	20,20	15,15	10,66	7,85
Injection System VMU plus Steel, zinc plated ≥ grade 5.8/Stainless steel A4/316 ≥ grade 70 and 1.4529 ≥ grade 70  Only uncracked concrete	Evaluation EBB170019-3	M8 h _{ef} ≥ 80	1,60	1,10	0,60	0,30
		M10 h _{ef} ≥ 90	2,60	1,80	0,90	0,50
		M12 h _{ef} ≥ 110	3,40	2,60	1,80	1,40
		M16 h _{ef} ≥ 125	6,30	4,80	3,40	2,70
		M20 h _{ef} ≥ 175	9,80	7,50	5,30	4,20
		M24 h _{ef} ≥ 210	14,00	10,80	7,60	6,00
		M27 h _{ef} ≥ 250	18,30	14,10	9,90	7,90
		M30 h _{ef} ≥ 280	22,30	17,20	12,10	9,60
Injection System VME Steel, zinc plated ≥ grade 5.8/Stainless steel A4/316 ≥ grade 70 and 1.4529 ≥ grade 70  Only uncracked concrete	Test report 3062/066/12	M8 h _{ef} ≥ 80	0,90	0,50	0,30	0,20
		M10 h _{ef} ≥ 90	3,20	1,80	1,10	0,75
		M12 h _{ef} ≥ 110	4,20	2,30	1,40	0,90
		M16 h _{ef} ≥ 125	8,25	5,30	3,80	3,00
		M20 h _{ef} ≥ 170	17,25	10,20	6,70	5,00
		M24 h _{ef} ≥ 210	24,85	14,75	9,70	7,20
		M27 h _{ef} ≥ 250	32,30	19,15	12,60	9,30
		M30 h _{ef} ≥ 280	39,50	23,40	15,40	11,35
Chemical Anchor V Steel, zinc plated ≥ grade 5.8/Stainless steel A4/316 ≥ grade 70 and 1.4529 ≥ grade 70 	Evaluation 21726/1	M 8	1,70	1,20	0,70	0,50
		M 10	3,00	2,20	1,40	0,90
		M 12	4,70	3,50	2,20	1,60
		M 16	8,80	6,50	4,20	3,00
		M 20	13,80	10,10	6,50	4,70
M 24	19,90	14,60	9,40	6,80		

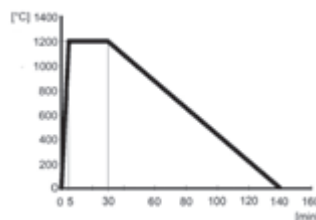
Fire Resistant Anchor Systems in tunnels

Tested according to ZTV tunnel temperature curve in cracked concrete, exposed to open flames, without fire protection.



Anchor system	IBMB test report	Size	Maximum tension load in fire tests according to ZTV tunnel temperature curve	
			Verankerungstiefe	Zuglast [kN]
Wedge Anchor BZ plus HCR Stainless steel 1.4529 	3212/1206-6	M 8	46 mm	1,00
		M 10	60 mm	1,90
		M 12	65 mm	3,00
		M 16	85 mm	5,50
		M 20	100 mm	6,80
Nail Anchor N, N-K Stainless steel A4, Stainless steel 1.4529 	2011-B-0279	N6	30 mm	0,12
		N-K	30 mm	0,12
Injection System VMZ HCR Stainless steel 1.4529 	GS 3.2/14-089-4Ä	60 M 10	60 mm	0,53
		75 M 10	75 mm	1,08
		75 M 12	75 mm	1,47
		70 M 12	70 mm	1,47
		80 M 12	80 mm	2,39
		95 M 12	95 mm	2,50
		100 M 12	100 mm	2,50
		110 M 12	110 mm	2,50
		125 M 12	125 mm	2,50
		90 M 16	90 mm	3,65
		105 M 16	105 mm	4,10
		125 M 16	125 mm	4,10
		145 M 16	145 mm	4,10
		160 M 16	160 mm	4,10
		115 M 20	115 mm	6,32
		170 M 20	170 mm	6,40
		190 M 20	190 mm	6,40
Injection System VMZ dynamic HCR Stainless steel 1.4529 	GS 3.2/14-089-4Ä	M 12	100 mm	2,50
		M 16	125 mm	4,10
Injection System VMZ-IG HCR Stainless steel 1.4529 	GS 3.2/14-089-4Ä	60 M 8	60 mm	0,50
		75 M 8	75 mm	0,50
		70 M 10	70 mm	1,08
		80 M 10	80 mm	1,08
		90 M 12	90 mm	2,50
		105 M 12	105 mm	2,50
		125 M 12	125 mm	2,50
		115 M 16	115 mm	4,10
		170 M 16	170 mm	4,10
170 M 20	170 mm	6,40		

A series of horizontal lines for taking notes, spanning the width of the page.

Product Range 2018

04/2018 LP E MKT 4.000 Printed in Germany



Highload Anchor



Wedge Anchor



Software



Accessories



Injection System



Chemical Anchor

Highload Anchor



... a solid connection

MKT Metall-Kunststoff-Technik
GmbH & Co.KG
Auf dem Immel 2
67685 Weilerbach, Germany

Phone +49 63 74/91 16-0
Fax +49 63 74/91 16-60
info@mkt.de
www.mkt.de